

LOUISIANA STATE PLUMBING CODE

2000 edition

otherwise referred to as

**Chapter XIV
Plumbing
Sanitary Code
State of Louisiana**

consisting of the

1994 Standard Plumbing Code^c

as revised by the

1999 Louisiana Amendments





M. J. "Mike" Foster, Jr.
GOVERNOR

STATE OF LOUISIANA
DEPARTMENT OF HEALTH AND HOSPITALS

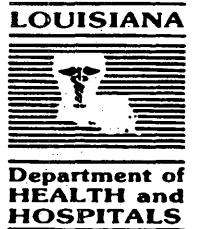

David W. Hood
SECRETARY

LOUISIANA STATE PLUMBING CODE

2000 edition

otherwise referred to as:

**Chapter XIV
Plumbing
Sanitary Code
State of Louisiana**

Chapter XIV (Plumbing) Revision Committee

MEMBERS

Sidney G. Becnel, R.S., *Chairman*, Engineering Services, Office of Public Health, LDHH, Baton Rouge
Larry Amberg, R.S., Sanitarian Services, Office of Public Health, LDHH, Alexandria
Michael Cazes, P.E., Engineering Services, Office of Public Health, LDHH, Alexandria
Jim Clarke, Chief Plumbing Inspector, City of Baton Rouge/Parish of East Baton Rouge, Baton Rouge
Jim Finley, P.E., Louisiana Plumbing - Heating -Cooling Contractors Association, New Orleans
Lee Fournet, P.E., Division of Engineering and Consulting Services, LDHH, Baton Rouge (*retired*)
A.J. Szabo, P.E., Domingue, Szabo, & Associates, Inc., Lafayette (*retired*)
Don Traylor, Executive Director, Louisiana State Plumbing Board, New Orleans

EX-OFFICIO MEMBERS

Barry Blue, R.S., Sanitarian Services, Office of Public Health, LDHH, Baton Rouge (*retired*)
Ragus Legendre, R.S., Sanitarian Services, Office of Public Health, LDHH, Baton Rouge

acting under the direction of:

Jimmy Guidry, M.D., State Health Officer, Office of Public Health, LDHH, Baton Rouge
Madeline McAndrew, Assistant Secretary, Office of Public Health, LDHH, Baton Rouge
Bobby Savoie, R.S., Director, Division of Environmental Health, Office of Public Health, LDHH, Baton Rouge
R. Douglas Vincent, P.E., Chief Engineer, Engineering Services, Office of Public Health, LDHH, Baton Rouge
James Antoon, R.S., Chief Sanitarian, Sanitarian Services, Office of Public Health, LDHH, Baton Rouge
Frank L. Deffes, R.S., Chief Sanitarian, Sanitarian Services, Office of Public Health, LDHH, N.O. (*retired*)
H.M. (Jack) Westholz, Jr., Esq., Chief, New Orleans Section, Bureau of Legal Affairs, LDHH, N.O. (*retired*)

R08/15/2000

SANITARY CODE
STATE OF LOUISIANA

CHAPTER XIV

PLUMBING

ADOPTED BY THE
STATE HEALTH OFFICER
in accordance with
LSA - R.S. 40:4

APPROVED BY THE
SECRETARY
of the
DEPARTMENT OF HEALTH AND HOSPITALS
in accordance with
LSA - R.S. 40:2

under the general powers and jurisdiction of the
STATE HEALTH OFFICER
and the
OFFICE OF PUBLIC HEALTH
in accordance with
LSA - R.S. 40:5

and

PROMULGATED
in accordance with
LSA - R.S. 49:951 et seq.
in the Louisiana Register 26:1481
(JULY 20, 2000)

EFFECTIVE DATE: OCTOBER 20, 2000

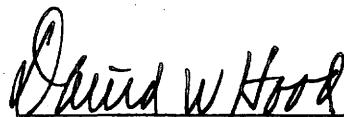

David W. Hood
Secretary, DHH

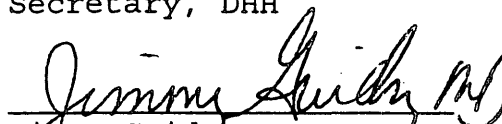

Jimmy Guidry, M.D.
State Health Officer

**Sanitary Code
State of Louisiana**

CHAPTER XIV

PLUMBING

14:001 Adoption of Louisiana State Plumbing Code

The Department of Health and Hospitals, Office of Public Health hereby adopts Chapter XIV (Plumbing) of the Sanitary Code, State of Louisiana to be comprised of the 1994 edition of the Standard Plumbing Code[©] as modified by the 1999 Louisiana Amendments to the 1994 Standard Plumbing Code[©]. The 1994 Standard Plumbing Code[©] is a copyrighted document published by the Southern Building Code Congress International, Inc.(SBCCI) and is recognized as one of several national model plumbing codes. The SBCCI will incorporate the 1999 Louisiana Amendments into the text of their 1994 Standard Plumbing Code[©]. After the Office of Public Health has proofread and approved the combined document to ensure accuracy and consistency with the 1999 Louisiana Amendments, SBCCI will print a separate copyrighted document entitled the "Louisiana State Plumbing Code". The "Louisiana State Plumbing Code" shall be synonymous to "Chapter XIV (Plumbing) of the Sanitary Code, State of Louisiana".

AUTHORITY NOTE: Promulgated in accordance with R.S. 40:4.

HISTORICAL NOTE: Promulgated by the Department of Health and Human Resources, Office of Health Services and Environmental Quality LR10:210 (March 1984), amended by the Department of Health and Hospitals, Office of Public Health, LR18:618 (June 1992), LR26:1481 (July 2000).

14:002 Availability

Information concerning purchasing copies of the Louisiana State Plumbing Code may be obtained by contacting the Southern Building Code Congress International, Inc., 900 Montclair Road, Birmingham, Alabama 35213-1206, (205) 591-1853 or by contacting the Chief Sanitarian, Office of Public Health, 6867 Bluebonnet Blvd. - Box 9, Baton Rouge, LA 70810, tel (225) 763-5553 or fax (225) 763-5552.

In addition, the Office of Public Health will purchase at least 33 copies of the Louisiana State Plumbing Code to be given to the Office of the State Library for distribution to various libraries designated as a recorder of state documents. Copies will be provided to the following libraries: LSU-BR, La Tech, UNO, LSU-Shreveport, McNeese, USL, NE La Univ., N.O. Public, NW La Univ., Nicholls, SE La Univ., Jefferson Parish Public (E & W), La College, Nunez Comm., Loyola, Southern-BR, Southern Univ. Law, SUNO, Shreve Memorial, Loyola Law, LSU Medical, Delgado, La Supreme Court, E.B.R. Public, Legislative Library, Grambling, Tulane, Library of Congress, State Library-BR, and the Recorder of State Documents in the Office of State Library. This will enable the general public to review and otherwise have accessibility to the document without the need to individually purchase a copy.

Copies of the Louisiana State Plumbing Code will also be provided to and may be reviewed (pursuant to a request to review public record) at the Office of Public Health's Division of Environmental Health's Central Office in Baton Rouge, any of the 9 Regional Engineering/Sanitarian offices, or any of the 64 Parish Health Unit sanitarian offices generally between the hours of 8:00 a.m. and 4:30 p.m. on regular work days.

AUTHORITY NOTE: Promulgated in accordance with R.S. 40:4.

HISTORICAL NOTE: Promulgated by the Department of Health and Human Resources, Office of Health Services and Environmental Quality LR10:210 (March 1984), amended by the Department of Health and Hospitals, Office of Public Health LR18:618 (June 1992), LR26:1481 (July 2000).

14:003 Effective Date

This rule shall become effective on October 20, 2000.

AUTHORITY NOTE: Promulgated in accordance with R.S. 40:4.

HISTORICAL NOTE: Promulgated by the Department of Health and Human Resources, Office of Health Services and Environmental Quality LR10:210 (March 1984), amended by the Department of Health and Hospitals, Office of Public Health LR18:618 (June 1992), LR26:1482 (July 2000).

14:004 1999 Louisiana Amendments

The 1999 Louisiana Amendments to the 1994 Standard Plumbing Code[©] are attached as follows (numerical citations comport with 1994 Standard Plumbing Code[©] format):

These amendments can be viewed at any Office of Public Health regional office or at the Division of Environmental Health's central office. (See addresses in the following Summary paragraph.)

AUTHORITY NOTE: Promulgated in accordance with R.S. 40:4.

HISTORICAL NOTE: Promulgated by the Department of Health and Human Resources, Office of Health Services and Environmental Quality LR10:210 (March 1984), amended by the Department of Health and Hospitals, Office of Public Health LR18:618 (June 1992), LR26:1482 (July 2000).

(Addresses for the Office of Public Health regional offices and its Division of Environmental Health central office are as follows: Region I, Plaza Towers Annex Bldg., 1001 Howard Ave. - Suite 100A, New Orleans, (504) 599-0102; Region II, 1772 Wooddale Blvd., Baton Rouge, (225) 925-7230; Region III, 106 Canal Blvd., Thibodaux, (504) 449-5007; Region IV, 825 Kaliste Saloom Rd., Brandywine III Bldg., Suite 100, Lafayette, (318) 262-5318; Region V, 4240 Sen. J. Bennett Johnston Ave., Lake Charles, (318) 491-2149; Region VI, 1500 Lee St., Alexandria, (318) 487-5186; Region VII, 1525 Fairfield Ave., Room 566, Shreveport, (318) 676-7485; Region VIII, 2913 Betin St., Monroe, (318) 362-5246; Region IX, 21454 Koop Drive, Suite 1C, Mandeville, (504) 871-1331; Division of Environmental Health Central Office, Blanche Appleby Computer Complex Bldg. (on the Jimmy Swaggert Ministry Campus), 6867 Bluebonnet Blvd. - Suite 201, Baton Rouge, (225) 763-5553.)

NOTE: The SBCCI Standard Codes are designed for adoption by state or local governments by reference only. Jurisdictions adopting them may make necessary additions, deletions and amendments in their adopting document. Incorporation of any part of the SBCCI Standard Codes in codes published by states, local governments, regulatory agencies, individuals or organizations is expressly prohibited. When your jurisdiction has adopted one or more of the SBCCI Standard Codes, please send a copy of the adopting document to the SBCCI headquarters office.

EXCEPTION: Local governments and jurisdictions within Louisiana which adopt their own local plumbing code must ensure that such local code does not conflict with the requirements of the Louisiana State Plumbing Code and is not less restrictive than the Louisiana State Plumbing Code requirements. Local plumbing codes are allowed to be more restrictive than the Louisiana State Plumbing Code. (See LA. R. S. 40:14)

COPYRIGHT© 2000

BY

SOUTHERN BUILDING CODE CONGRESS INTERNATIONAL, INC.

900 MONTCLAIR ROAD

BIRMINGHAM, ALABAMA 35213-1206

205-591-1853

PRINTED IN U.S.A.

All rights reserved. No part of this book may be reproduced or transmitted in any form or by any means, electronic or mechanical, including photocopy, recording or by an information storage and retrieval system, without advance permission in writing from the publisher. For information contact: Chief Executive Officer, Southern Building Code Congress International, Inc., 900 Montclair Road, Birmingham, Alabama 35213-1206.

PREFACE

The purpose of the Standard Plumbing Code is to serve as a comprehensive regulatory document to guide decisions aimed at protecting the public's life, health and welfare in the built environment. This protection is provided through the adoption and enforcement, by state and local governments, of the performance-based provisions contained herein.

The use of performance-based requirements encourages the use of innovative building designs, materials and construction systems while at the same time recognizing the merits of the more traditional materials and systems. This concept promotes maximum flexibility in building design and construction as well as assuring a high degree of life safety.

The Standard Plumbing Code incorporates, by reference, nationally recognized consensus standards for use in judging the performance of materials and systems. This provides for the equal treatment of both innovative and traditional materials and systems, provides for the efficient introduction of new materials into the construction process and assures a high level of consumer protection.

The Standard Plumbing Code is intended to be adopted by reference through statute or ordinance and enforced by state and local governments, governmental agencies or other authorities having jurisdiction. Sample adopting legislation is printed in this document for that purpose. In preparation for adopting this code, the authority having jurisdiction should specifically consider including such items as inspection fees, permit fees and penalties or fines for noncompliance in the adopting legislation since these items vary considerably from one jurisdiction to another and cannot be effectively included in a model code.

The Standard Plumbing Code was first adopted in November, 1955 by a resolution of the Board of Trustees of the Southern Building Code Congress International. Revised editions have been published since that time at approximate three-year intervals.

This Standard Plumbing Code is dedicated to the organizations and individuals, including code officials, architects, engineers and industry representatives, who have volunteered their time and knowledge to make this the most comprehensive and up-to-date code available.

Broken vertical bars in the margin indicate Louisiana changes to the 1994 edition of the Standard Plumbing Code.



Stars in the margin indicate Louisiana deletions from the 1994 edition of the Standard Plumbing Code.



The Standard Plumbing Code was adopted November 1955, by the Board of Trustees of the Southern Building Code Congress International. The code has been kept current through revisions and changes officially approved at Annual Research and Education Conferences held at:

ST. PETERSBURG, FLORIDA, November 10-13, 1957
BILOXI, MISSISSIPPI, November 9-13, 1958
CHATTANOOGA, TENNESSEE, November 1-4, 1959
BIRMINGHAM, ALABAMA, October 30-November 2, 1960
SHREVEPORT, LOUISIANA, November 5-9, 1961
CLEARWATER, FLORIDA, November 11-15, 1962
DALLAS, TEXAS, November 10-14, 1963
MOBILE, ALABAMA, October 25-29, 1964
MIAMI, FLORIDA, November 7-11, 1965
MEMPHIS, TENNESSEE, November 13-17, 1966
NORFOLK, VIRGINIA, November 12-16, 1967
NEW ORLEANS, LOUISIANA, October 27-31, 1968
JACKSONVILLE, FLORIDA, November 2-6, 1969
ATLANTA, GEORGIA, November 1-5, 1970
NEW ORLEANS, LOUISIANA, October 31-November 4, 1971
HOUSTON, TEXAS, October 29-November 3, 1972
JACKSONVILLE, FLORIDA, October 28-November 2, 1973
BIRMINGHAM, ALABAMA, November 3-7, 1974
NASHVILLE, TENNESSEE, November 2-6, 1975
MYRTLE BEACH, SOUTH CAROLINA, November 14-18, 1976
ORLANDO, FLORIDA, October 23-27, 1977
HOUSTON, TEXAS, October 15-19, 1978
ATLANTA, GEORGIA, October 14-18, 1979
MEMPHIS, TENNESSEE, October 26-30, 1980
ORLANDO, FLORIDA, October 25-29, 1981
NASHVILLE, TENNESSEE, October 17-21, 1982
GREENSBORO, NORTH CAROLINA, October 9-13, 1983
SAVANNAH, GEORGIA, October 28-November 1, 1984
CORPUS CHRISTI, TEXAS, October 27-31, 1985
ORLANDO, FLORIDA, October 19-23, 1986
MEMPHIS, TENNESSEE, October 25-29, 1987
CHARLESTON, SOUTH CAROLINA, October 23-27, 1988
CHARLOTTE, NORTH CAROLINA, October 22-26, 1989
NEW ORLEANS, LOUISIANA, October 1-5, 1990
TAMPA, FLORIDA, October 25-November 2, 1991
CORPUS CHRISTI, TEXAS, October 25-29, 1992
LITTLE ROCK, ARKANSAS, October 17-21, 1993

THE STANDARD CODES

Standard Amusement Device Code
Standard Building Code
Standard Existing Buildings Code
Standard Fire Prevention Code
Standard Gas Code
Standard Housing Code
Standard Mechanical Code
Standard Plumbing Code
Standard Swimming Pool Code
Standard Unsafe Building Abatement Code

CODE-RELATED PUBLICATIONS

Standard for Proscenium Curtains
Standard for Existing High Rise Buildings
Standard for Floodplain Management
Standard for Soil Expansion
Standard for Sound Control
Standard for Textile Wall Covering Test
Standard for Roof Tile Test
Standard for Hurricane Resistant Residential Construction
Standard Building Code Commentary
Standard Gas Code Commentary
Standard Mechanical Code Commentary
Standard Plumbing Code Handbook
One and Two Family Dwelling Code Commentary

EDUCATION PUBLICATIONS

Building Official Management
Building Principles and Code Applications
Electrical Inspection and Plans Examination
Electrical Principles and Code Applications (Residential)
Fire Protection Principles and Code Applications
Hurricane Resistant Construction
Legal Aspects of Code Administration
Mechanical Principles and Code Applications
One and Two Family Dwelling Inspection
Plumbing Principles and Code Applications
Rehabilitation and Housing Principles and Code Applications
Structural Principles and Code Applications

SAMPLE ORDINANCE TO ADOPT STANDARD CODES

ORDINANCE NO. _____

AN ORDINANCE TO ADOPT VARIOUS STANDARD CODES RELATING TO INSPECTION ACTIVITIES OF THE (CITY, COUNTY, STATE) AND ENFORCEMENT OF BUILDING PROVISIONS AS PROVIDED IN SAID CODES.

Section 1: WHEREAS, it is the desire of, (NAME OF ADOPTING AUTHORITY) to adopt, in all respects, the various Standard Codes relating to amusement devices, building, fire prevention, gas, housing, mechanical, plumbing and swimming pools and WHEREAS, the adoption of these codes is done to facilitate proper inspection activities by (CITY, COUNTY, STATE) relating to construction and to maintenance of buildings within said (CITY, COUNTY, STATE) and relating to public safety, health and general welfare; NOW, THEREFORE, BE IT ORDAINED BY (NAME OF ADOPTING AUTHORITY) that the following codes are hereby adopted by reference as though they were copied herein fully:

- Standard Amusement Device Code - 1985 Edition
- Standard Building Code - 1994 Edition
- Standard Existing Buildings Code - 1988 Edition with 1991/1994 Revisions
- Standard Fire Prevention Code - 1994 Edition
- Standard Gas Code - 1994 Edition
- Standard Housing Code - 1994 Edition
- Standard Mechanical Code - 1994 Edition
- Louisiana State Plumbing Code, - 2000 Edition
- Standard Swimming Pool Code - 1994 Edition
- Standard Unsafe Building Abatement Code - 1985 Edition

Section 2: BE IT FURTHER ORDAINED BY (NAME OF ADOPTING AUTHORITY) that any matters in said codes which are contrary to existing Ordinances of (CITY, COUNTY, STATE) shall prevail and that Ordinance No. _____, entitled (fill in here the complete title of the present building ordinance or ordinances in effect at the present time) are hereby repealed and, to that extent any existing Ordinances to the contrary are hereby repealed in that respect only.

Section 3: BE IT FURTHER ORDAINED that within said codes, when reference is made to the duties of a certain official named therein, that designated official of (CITY, COUNTY, STATE) who has duties corresponding to those of the named official in said code shall be deemed to be the responsible official insofar as enforcing the provisions of said code are concerned.

Section 4: BE IT FURTHER ORDAINED that this ordinance shall take effect and be in force from and after its passage, the public welfare requiring it.

PASSED AND APPROVED BY (NAME OF ADOPTING AUTHORITY) on the day of _____

ATTEST:
CLERK:

BY:

Louisiana State Plumbing Code 2000 edition

TABLE OF CONTENTS

CHAPTER 1 ADMINISTRATION

101 Title and Scope	1
102 Powers and Duties of the Plumbing Official	1
103 Permits	2
104 Tests	2
105 Variances	2
106 Severability	2
107 Violations and Penalties	2

CHAPTER 2 DEFINITIONS

201 General	3
202 Definition of Terms	3

CHAPTER 3 GENERAL REGULATIONS

301 General	11
302 Definitions	12
303 Materials	12
304 Protection of Pipes	15
305 Trenching, Excavation and Backfill	16
306 Structural Safety	16
307 Fittings	17
308 Types of Joints	17
309 Use of Joints	18
310 Hangers and Supports	18
311 Tests	19
312 Appendix References	19

CHAPTER 4 PLUMBING FIXTURES

401 General	21
402 Definitions	21
403 Installation	21
404 Location of Fixtures	21
405 Materials and Performance Standards	22
406 Water Conservation	22
407 Minimum Plumbing Fixtures	22
408 Fixture Outlets	29
409 Fixture Types	29
410 Appendix References	32

CHAPTER 5 WATER HEATERS

501 General	33
502 Definitions	33
503 Standards	33
504 Minimum Capacities for Residential Water Heaters	33
505 Prohibited Installations	35
506 Connections	35
507 Safety Devices	35

CHAPTER 6 WATER SUPPLY AND DISTRIBUTION

601 General	37
602 Definitions	37
603 Materials	37
604 Quality of Water Supply	38
605 Color Code Identification	38
606 Protection of Potable Water Supply	39
607 Sizing of Water Distribution System	41
608 Water Service Pipe and Fittings	42
609 Water Pumping and Storage Equipment	43

610 Water Supply Control	44
611 Water Distribution Pipe, Tubing and Fittings	44
612 Joints	45
613 Safety Devices	46
614 Miscellaneous	46
615 Water Treatment Units	47
616 Solar Energy Utilization	47
617 Appendix References	47

CHAPTER 7 SANITARY DRAINAGE

701 General	49
702 Definitions	49
703 Materials	49
704 Building Sewer	50
705 Drainage Piping Installation	50
706 Joints	51
707 Use of Joints	51
708 Connections Between Drainage Piping and Fixtures	52
709 Prohibited Joints and Connections	52
710 Cleanouts	52
711 Size of Cleanouts	53
712 Cleanout Clearances	53
713 Fixture Units	53
714 Drainage System Sizing	54
715 Offsets in Drainage Piping in Buildings of Five Stories or More	55
716 Waste Stacks Serving Kitchen Sinks	55
717 Sumps and Ejectors	56
718 Appendix References	56

CHAPTER 8 INDIRECT AND SPECIAL WASTES

801 General	57
802 Definitions	57
803 Material and Size	57
804 Indirect Waste Connections	57
805 Limitations	57
806 Indirect Waste Methods	57
807 Indirect Waste Methods	58
808 Appendix References	58

CHAPTER 9 VENTS

901 General	59
902 Definitions	59
903 Materials	59
904 Vent Stacks	59
905 Vent Terminals	59
906 Vent Grades and Connections	60
907 Bar and Fountain Sink Traps	60
908 Fixture Vents	61
909 Common Vent	62
910 Vents For Fixture Trap Below Trap Dip	63
911 Wet Venting	63
912 Stack Venting	63
913 Individual Fixture Reventing	64
914 Circuit and Loop Venting	65
915 Pneumatic Ejectors	65
916 Relief Vents—Stacks of More Than 10 Branch Intervals	65
917 Offset Vents	66
918 Main Vents to Connect At Base	66
919 Vent Headers	66
920 Size and Length of Vents	66
924 Appendix References	67

CHAPTER 10 TRAPS

1001 General	69
1002 Definitions	69
1003 Type and Size of Traps and Fixture Drains	69
1004 Interceptors and Separators	71

CHAPTER 11 STORM DRAINAGE

1101 General	73
1102 Definitions	73
1103 Materials	73
1104 Specifications	73
1106 Conductors and Connections	74
1107 Roof Drains	74
1108 Size of Leaders and Storm Drains	74
1109 Secondary (Emergency) Roof Drains	75
1111 Values for Continuous Flow	75
1113 Appendix References	75

CHAPTER 12 ALTERNATE DESIGNED PLUMBING SYSTEMS

1201 General	77
1202 Requirements for Approval	77
1203 Tests	77
1204 Third Party Notification	78

CHAPTER 13 SPECIAL PIPING AND STORAGE SYSTEMS

1301 Hospital Systems	79
1302 Medical Gas and Medical Vacuum Systems	79

CHAPTER 14 REFERENCE STANDARDS

1401 Scope	81
1402 Referenced Standards	81
1403 Organizations	85

APPENDIX CHAPTERS

APPENDIX A Roof Drain Sizing Method	87
* APPENDIX B Travel Trailers and Travel Trailer Parks	89
* APPENDIX C Mobile/Manufactured Homes and Mobile/Manufactured Home Parks	93
* APPENDIX D Cross-Connection Control	97
* APPENDIX E Private Sewage Disposal	101
APPENDIX F Sizing of Water Piping System	103
* APPENDIX G Medical Facilities Plumbing Systems	113
APPENDIX H Permit Fees	119
* APPENDIX I Installation of Building Sewers	121
APPENDIX J Illustrations	123
APPENDIX K Vacuum Drainage Systems	131
APPENDIX L Alternate Designed Plumbing Systems	133
* APPENDIX M Procedures for Design, Construction, and Installation of Interceptors and Separators	143

*These appendices are a requirement of this code. Others are for information only.

Index	155
Metric Conversions Table	163

CHAPTER 1 ADMINISTRATION

101 TITLE AND SCOPE

101.1 Title

The 1994 *Standard Plumbing Code*® published by the *Southern Building Code Congress International, Inc.* as modified by the 1999 Louisiana amendments shall constitute and be known and may be cited as “the *Louisiana State Plumbing Code*” hereinafter referred to as “this Code.”

101.1.1 Purpose. The purpose of this chapter is to provide for the administration and enforcement of this Code.

101.2 Code Remedial

101.2.1 General. This Code is hereby declared to be remedial, and shall be construed to secure the beneficial interests and purposes thereof-which are public safety, health and general welfare-by regulating the installation and maintenance of all plumbing.

101.2.2 Quality Control. Quality control of materials and workmanship is not within the purview of this Code except as it relates to the purpose stated herein.

101.2.3 Permitting and Inspection. The inspection or permitting of any building or plan by any jurisdiction, under the requirements of this Code shall not be construed in any court as a warranty of the physical condition of such building or the adequacy of such plan. No jurisdiction nor any employee thereof shall be liable in tort for damages for any defect or hazardous or illegal condition or inadequacy in such building or plan, nor for any failure of any component of such building, which may occur subsequent to such inspection or permitting.

101.3 Scope

101.3.1 Applicability. The provisions of this Code shall apply to every plumbing installation, including alterations, repairs, replacement, equipment, appliances, fixtures, fittings and appurtenances.

101.3.2 Federal and State Authority. The provisions of this Code shall not be held to deprive any Federal or state agency, or any applicable governing authority having jurisdiction, of any power or authority which it had on the effective date of the adoption of this Code or of any remedy then existing for the enforcement of its orders, nor shall it deprive any individual or corporation of its legal rights provided by law.

101.3.3 Appendices. The appendices included in this Code are not intended for enforcement unless specifically referenced in the Code text, stated in the appendix or specifically included in the adopting ordinance or promulgated regulations.

101.3.4 Referenced Standards. Standards referenced in this Code shall be considered an integral part of this Code without separate adoption. If specific portions of a standard are denoted by Code text, only those portions of the standard shall be enforced. Where Code provisions conflict with a standard, the Code provisions shall be enforced. Permissive and advisory provisions in a standard shall not be construed as mandatory.

101.3.5 Maintenance. All plumbing systems, both existing and new, and all parts thereof, shall be maintained in a safe and sanitary condition. All devices or safeguards which are required by this Code when constructed, altered, or repaired, shall be maintained in good working order. The owner, or his designated agent, shall be responsible for the maintenance of the plumbing system.

101.4 Existing Buildings

101.4.1 General. Alterations, repairs or rehabilitation work may be made to any existing plumbing installations without requiring the installations to comply with all the requirements of this Code provided that the alteration, repair or rehabilitation work conforms to the requirements of this Code for new construction. The Plumbing Official shall determine the extent to which the existing plumbing installation shall be made to conform to the requirements of this Code for new construction.

101.4.2 Change of Occupancy. If the occupancy classification of an existing building is changed, the plumbing installation shall be made to conform to the intent of this Code as required by the Plumbing Official.

101.5 Special Historic Buildings

The provisions of this Code relating to the installation, alteration, repair, enlargement, restoration, replacement or relocation of plumbing installations shall not be mandatory for existing buildings or structures identified and classified by the state or local jurisdiction as historic buildings when such installations are judged by the Plumbing Official to be safe and in the public interest of health, safety and welfare regarding any proposed installation, alteration, repair, enlargement, restoration, relocation or replacement.

102 POWERS AND DUTIES OF THE PLUMBING OFFICIAL

102.1 Authority

Pursuant to R.S. 40:4.A(7) the State Health Officer is required to promulgate the Plumbing Code and pursuant to R.S. 40:5(3) the State Health Officer has the authority to enforce the Plumbing Code. Any enforcement action by the State Health Officer shall be in accordance with Chapter 1 of

the Sanitary Code of the State of Louisiana and/or applicable state laws.

102.2 Right of Entry

102.2.1 Whenever necessary to make an inspection to enforce any of the provisions of this Code, or whenever the Plumbing Official has reasonable cause to believe that there exists in any building or upon any premises any condition or code violation which makes such building or premises unsafe, dangerous or hazardous, the Plumbing Official may enter such building or premises at all reasonable times to inspect the same or to perform any duty imposed upon the Plumbing Official by this Code, provided that if such building or premises is occupied, he shall first present proper credentials and request entry. If such building or premises is unoccupied, he shall first make a reasonable effort to locate the owner or other persons having charge or control of the building or premises and request entry. If such entry is refused, the Plumbing Official shall have recourse to every remedy provided by law to secure entry.

102.2.2 When the Plumbing Official shall have first obtained a proper inspection warrant or other remedy provided by law to secure entry, no owner or occupant or any other persons having charge, care or control of any building of premises shall fail or neglect after proper request is made as herein provided, to promptly permit entry therein by the Plumbing Official for the purpose of inspection and examination pursuant to this Code.

102.3 Enforcement

Upon determination that any plumbing system is in violation of, or not in conformity with, the provisions of this Code, the Plumbing Official may initiate enforcement action in accordance with applicable laws, regulations and/or ordinances.

102.4 Revocation of Permits

102.4.1 Misrepresentation of Application. The Plumbing Official may revoke a permit or approval, issued under the provisions of this Code, in case there has been any false statement or misrepresentation as to the material fact in the application or plans on which the permit or approval was based.

102.4.2 Violation of Code Provisions. The Plumbing Official may revoke a permit upon determination by the Plumbing Official that the installation, erection, alteration or repair of the plumbing installation for which the permit was issued is in violation of or not in conformity with, the provisions of this Code.

102.5 Unsafe Installations

All plumbing installations regardless of type, which are unsafe or which constitute a hazard to human life, health or welfare are hereby declared illegal and shall be abated by repair and rehabilitation or by demolition.

102.6 Requirements Not Covered By Code

Any requirements necessary for the strength or stability of an existing or proposed plumbing installation, or for the public safety, health and general welfare, not specifically covered by this Code, shall be determined by the Plumbing Official.

102.7 Alternate Materials and Methods of Construction

The provisions of this Code are not intended to prevent the use of any material or method of construction not specifically prescribed by this Code, provided any such alternate has been approved by the Plumbing Official. The Plumbing Official shall approve any such alternate, provided he finds that the alternate for the purpose intended is at least the equivalent of that prescribed in this Code in quality, strength, effectiveness, durability and safety. The Plumbing Official shall require that sufficient evidence or proof be submitted to substantiate any claim made regarding its use.

103 PERMITS

A person, firm or corporation shall not install, enlarge, alter, repair, improve, remove, convert or replace any plumbing work, or cause the same to be done, without first obtaining a plumbing permit (where such permits are required by state, parish, city or other local laws or ordinances) from the Plumbing Official. Where such permits are not available the property owner, contractor and installer shall be jointly responsible for the installation being in compliance with the requirements of the Code.

104 TESTS

The Plumbing Official may require tests or test reports as proof of compliance. Required tests are to be made at the expense of the owner or his agent, by an approved testing laboratory or other approved agency.

105 VARIANCES

The Plumbing Official may vary the application of any provision of this Code to any particular case when, in his/her opinion, the enforcement thereof would do manifest injustice, and would be contrary to the spirit and purpose of this Code or public interest.

106 SEVERABILITY

If any section, subsection, sentence, clause or phrase of this Code is for any reason held to be unconstitutional, such decision shall not affect the validity of the remaining portions of this Code.

107 VIOLATIONS AND PENALTIES

Any person, firm, corporation or agent; contractor; and/or installer who violates a provision of this Code shall be subject to enforcement action by the Plumbing Official in accordance with applicable laws, regulations and/or ordinances.

CHAPTER 2 DEFINITIONS

201 GENERAL

201.1 Scope

For the purpose of this code, certain abbreviations, terms, phrases, words and their derivatives shall be construed as set forth in this chapter or the chapter to which they are unique.

201.2 Tense, Gender, and Number

Words used in the present tense include the future. Words in the masculine gender include the feminine and neuter. Words in the feminine and neuter gender include the masculine. The singular number includes the plural and the plural number includes the singular.

201.3 Words Not Defined

Words not defined herein shall have the meanings stated in the other chapters of the Louisiana State Sanitary Code which are adopted or may be adopted, the Standard Building Code, the Standard Mechanical Code, the Standard Gas Code or the Standard Fire Prevention Code. When words not defined herein are defined in both the Louisiana State Sanitary Code and in one of these Standard Codes, the definition contained within the Louisiana State Sanitary Code shall be given preference as it pertains to health and/or health standards. Words not defined in any of these source documents shall have the meanings stated in the Merriam-Webster's Collegiate Dictionary-Tenth Edition, as revised.

202 DEFINITION OF TERMS

ACCESS COVER - a removable plate, usually secured by bolts or screws, to permit access to a pipe or pipe fitting for the purposes of inspection, repair or cleaning.

ACCESSIBLE - having access to but which first may require the removal of a panel, door or similar covering of the item described. See Readily Accessible.

ADMINISTRATIVE AUTHORITY - see Plumbing Official.

★
AIR BREAK (DRAINAGE SYSTEM) - a piping arrangement in which a drain from a fixture, device, appliance or apparatus discharges indirectly into a sink or other receptor with the indirect waste pipe terminating at a point below the flood level rim of the receiving sink or other receptor. An unobstructed horizontal distance of free atmosphere between the outside of the indirect waste pipe and the inside of the receiving sink or other receptor must exist so as to allow a back-flow of sewage to spill over the flood level rim of the receiving sink or other receptor to prevent such back-flow from reaching the fixture, device, appliance or apparatus served by the indirect waste pipe.

AIR GAP (DRAINAGE SYSTEM) - the unobstructed vertical distance through the free atmosphere between the outlet waste pipe and the flood level rim of the receptacle into which it is discharging.

AIR GAP (WATER DISTRIBUTION) - in a water supply system, the unobstructed vertical distance through the free atmosphere between the lowest opening from any pipe or faucet supplying water to a tank, plumbing fixture or other device and the flood-level rim of the receptacle.

ANCHORS - see Supports.

AND/OR - in a choice of two code provisions, signifies that use of both provisions will satisfy the code requirement and use of either provision is acceptable also.

ANTI-SCALD VALVE (*see Scald Preventative Valve*)

APPROVED - approved by the plumbing official or other authority having jurisdiction.

AREA DRAIN - a receptacle designed to collect surface or rain water from an open area.

BACKFLOW - the flow of water or other liquids, mixtures, or substances into the distribution pipes of a potable supply of water from any source or sources other than its intended source. See Back-Siphonage.

BACKFLOW CONNECTION - any arrangement whereby backflow can occur.

BACKFLOW PREVENTER - a device which prevents the reverse flow of water due to atmospheric or higher pressure by means of positive check members in addition to atmospheric ports which provide back-siphonage protection.

BACK-SIPHONAGE - the flowing back of used, contaminated, or polluted water from a plumbing fixture or vessel into a water supply pipe due to a negative pressure in such pipe. See Backflow.

BACK WATER VALVE - a device (check valve) installed in a drain or pit or in the sewer or drainage system to prevent sewage or drainage from backing into low levels through fixtures or devices not installed sufficiently above sewer or drainage systems.

BATTERY OF FIXTURES - any group of two or more similar adjacent fixtures which discharge into a common horizontal waste or soil branch.

BATTERY VENTING - the horizontal wet venting of a number of individual fixture drains, connected horizontally to a branch soil or waste pipe which is circuit or loop vented.

BOILER BLOW-OFF - an outlet on a boiler to permit emptying or discharge of sediment.

BRANCH - any part of the piping system other than a main, riser, or stack.

BRANCH, FIXTURE - see Fixture Branch.

BRANCH, HORIZONTAL - see Horizontal Branch.

BRANCH INTERVAL - a length of soil or waste stack corresponding in general to a story height, but in no case less than 8 ft (2438 mm) within which the horizontal branches from one floor or story of a building are connected to the stack.

BRANCH VENT - a vent connecting one or more individual vents with a vent stack or stack vent.

BUILDING - a structure built, erected, and framed of component structural parts designed for the housing, shelter, enclosure, or support of persons, animals, or property of any kind.

BUILDING CLASSIFICATION - the arrangement in the Standard Building Code for the designation of buildings in classes based upon their use or occupancy.

BUILDING DRAIN - that part of the lowest piping of a drainage system which receives the discharge from soil, waste and other drainage pipes inside the walls of the building and conveys it to the building sewer 3 ft (914 mm) outside the building wall.

BUILDING SEWER - that part of the horizontal piping of a drainage system which extends from the ends of the building drain and which receives the discharge of the building drain and conveys it to a public sewer, private sewer, individual sewage-disposal system or other point of disposal.

BUILDING STORM DRAIN - a building drain used for conveying rain water, surface water, ground water, subsurface water, condensate, cooling water or other similar discharge to a building storm sewer, extending to a point not less than 3 ft (914 mm) outside the building wall.

BUILDING (HOUSE) STORM SEWER - the extension from the building storm drain to the public storm sewer or other point of disposal.

BUILDING (HOUSE) SUBDRAIN - that portion of a drainage system which cannot drain by gravity into the building sewer.

BUILDING (HOUSE) TRAP - a device, fitting, or assembly of fittings installed in the building drain to prevent circulation of air between the drainage system of the building and the building sewer.

CIRCUIT VENT - a branch vent that serves two or more traps and extends from in front of the last fixture connection of a horizontal branch to the vent stack.

COMBINATION FIXTURE - a fixture combining one sink and tray or a two or three-compartment sink or tray in one unit.

COMBINATION WASTE AND VENT SYSTEM - a specially designed system of waste piping embodying the horizontal wet venting of one or more sinks or floor drains by means of a common waste and vent pipe adequately sized to provide free movement of air above the flow line of the drain.

COMMON VENT - a vent connecting at the junction of two fixture drains and serving as a vent for both fixtures.

CONDUCTOR - see Leader.

CONTINUOUS VENT - a vertical vent that is a continuation of the drain to which it connects.

CONTINUOUS WASTE - a drain from two or three fixtures connected to a single trap.

CRITICAL LEVEL - the minimum elevation above the flood level rim of the fixture or receptacle served at which the device may be installed. The critical level marking on a backflow prevention device or vacuum breaker is a point established by the manufacturer to an accepted standard usually stamped on the device by the manufacturer. When a backflow prevention device does not bear a critical level marking, the bottom of the vacuum breaker, combination valve or the bottom of any approved device shall constitute the critical level.

CROSS CONNECTION - any physical connection or arrangement between two otherwise separate piping systems, one of which contains potable water and the other, water of unknown or questionable safety, whereby water may flow from one system to the other, the direction of flow depending on the pressure differential between the two systems. See Backflow and Back-Siphonage.

CROWN OF TRAP - the topmost point of the inside of a trap outlet.

DEAD END - a branch leading from a soil, waste, or vent pipe, building drain, or building sewer, which is terminated at a developed distance of 2 ft (610 mm) or more by means of a plug or other closed fitting.

DEPTH OF WATER SEAL - the depth of water which would have to be removed from a fully charged trap before air could pass through the trap.

DEVELOPED LENGTH - the length of a pipe along the center line of the pipe and fittings.

DIAMETER - the nominal diameter as designated commercially, unless otherwise stated.

★
DOMESTIC - connected with supply and service to man and activities of his household, private residences, offices, and institutions. Water for and liquid waste from lavatories, water closets, tubs and showers, kitchens, sinks, and laundries are considered domestic.

DOUBLE OFFSET - two changes of direction installed in succession or series in continuous pipe.

DOWNSPOUT - see Leader in 1102.

DRAIN - any pipe which carries waste water or waterborne wastes in a building drainage system.

DRAINAGE PIPING - see Drainage System.

DRAINAGE SYSTEM - all the piping within public or private premises, which conveys sewage, rain water, or other liquid wastes to a legal point of disposal, but not including the mains of a public sewer system or private or public sewage treatment or disposal plant.

DURHAM SYSTEM - a term used to describe soil or waste systems where all piping is of threaded pipe, tubing, or other such rigid construction, using recessed drainage fittings to correspond to the types of piping.

EFFECTIVE OPENING - the minimum cross-sectional area at the point of water supply discharge (or indirect waste pipe discharge), measured or expressed in terms of (1) diameter of a circle, or (2) if the opening is not circular, the diameter of a circle of equivalent cross-sectional area. Applicable to air gap.

EXISTING WORK - a plumbing system or any part thereof which has been installed prior to the effective date of this code.

FIXTURE BRANCH - a pipe connecting several fixtures.

FIXTURE DRAIN - the drain from the trap of a fixture to the junction of that drain with any other drain pipe.

FIXTURE SUPPLY - a water supply pipe connecting the fixture with the fixture branch.

FIXTURE UNIT - a quantity in terms of which the load-producing effects on the plumbing system of different kinds of plumbing fixtures are expressed on some arbitrarily chosen scale.

FIXTURE UNIT FLOW RATE - the total discharge flow in gallons per minute of a single fixture divided by 7.5 which provides the flow rate of that particular plumbing fixture as a unit of flow. Fixtures are rated as multiples of this unit flow. (One gallon per minute equals 0.0631 liters per second.)

FLOOD LEVEL RIM - the top edge of the receptacle from which water overflows.

FLOOR DRAIN - a plumbing fixture for recess in the floor having a floor level strainer intended for the purposes of the collection and disposal of waste water used in cleaning the floor and for the collection and disposal of accidental spillage to the floor. This definition does not include floor sinks and indirect liquid waste receptors.

FLOOR SINK - a type of indirect liquid waste receptor designed with a removable basket strainer or beehive strainer for the purpose of receiving the discharge from indirect liquid waste pipes only. This classification does not include floor drains with floor level strainers only but may include 3-inch (76 mm) drains with floor level strainers which incorporate funnel drains as an integral part thereof.

FLUSH TANK - a tank located above or integral with water closets, urinals, or similar fixtures for the purpose of flushing the usable portion of the fixture.

FLUSH VALVES - a device located at the bottom of the tank for the purpose of flushing water closets and similar fixtures.

FLUSHOMETER TANK - a device integrated within an air accumulation vessel which is designed to discharge a predetermined quantity of water to fixtures for flushing purposes.

FLUSHOMETER VALVE - a device which discharges a predetermined quantity of water to fixtures for flushing purposes and is actuated by direct water pressure.

FROSTPROOF CLOSET - a hopper that has no water in the bowl and has the trap and the control valve for its water supply installed below the frost line.

GANG SHOWER - two or more showers in a common area within an institutional building.

GRADE - the slope or fall of a line of pipe in reference to a horizontal plane. In drainage it is usually expressed as the fall in a fraction of an inch per foot length of pipe.

GREASE INTERCEPTOR - an interceptor of less than 125 gallon capacity which is designed and installed so as to separate and retain grease and which is generally installed indoors entirely above grade.

GREASE TRAP - an interceptor of at least 125 gallon capacity which is designed and installed so as to separate and retain grease and which is generally installed below grade outdoors with provisions for above grade accessibility for cleaning purposes.

HANGERS - see Supports.

HORIZONTAL BRANCH - a drain pipe extending laterally from a soil or waste stack or building drain, with or without vertical sections or branches, which receives the discharge from one or more fixture drains and conducts it to the soil or waste stack or to the building (house) drain.

HORIZONTAL PIPE - any pipe or fitting which makes an angle of more than 45 degrees (0.785 rad) with the vertical.

HOUSE DRAIN - see Building Drain.

HOUSE SEWER - see Building Sewer.

HOUSE TRAP - see Building Trap.

INDIRECT WASTE RECEPTOR - a plumbing fixture designed specifically to collect and dispose of liquid waste from other plumbing fixtures, plumbing equipment or appliances which are required to discharge to the drainage system through an air gap. The following type fixtures fall within the classification of indirect liquid waste receptors: Floor sinks, mop receptors, service sinks, and standpipe drains with integral air gaps, and may include others when approved as such by the plumbing official.

INDIRECT WASTE PIPE - a pipe that does not connect directly with the drainage system but conveys liquid wastes by discharging into a plumbing fixture or receptacle which is directly connected to the drainage system.

INDIVIDUAL SEWAGE DISPOSAL SYSTEM - a system for disposal of domestic sewage by means of a septic tank or mechanical treatment, designed for use apart from a public sewer to serve a single establishment or building. To be approved by the plumbing official.

INDIVIDUAL VENT - a pipe installed to vent a fixture trap and which connects with the vent system above the fixture served or terminates in the open air.

INDUSTRIAL WASTES - liquid wastes resulting from the processes employed in industrial establishments and free of fecal matter.

INSANITARY - as opposed to "sanitary"; deficient in sanitation; unclean to a degree to be injurious to health; careless or dangerous hygienic conditions; contrary to sanitary principles.

INTERCEPTOR - an automatic or manual device designed and installed to separate and retain deleterious, hazardous, or undesirable matter from normal wastes for proper disposal, rendering or recycling, and also permits normal sewage and liquid wastes to discharge into the disposal terminal by gravity.

JOURNEYMAN PLUMBER - a natural person who possesses the necessary qualifications and knowledge to install, alter and/or repair plumbing systems; is licensed as such by the Louisiana State Plumbing Board; is supervised

by a master plumber and is in the employ of an employing entity. [see LSA - R.S. 37:1377(B)]

LEADER - the water conductor (downspout) from the roof to the building storm drain or other means of disposal.

LEAD FREE PIPE AND FITTINGS - containing not more than 8.0% lead.

LEAD FREE SOLDER AND FLUX - containing not more than 0.2% lead.

LISTED - equipment or materials included in a list published by an approved nationally recognized testing laboratory, inspection agency or other organization concerned with product evaluation that maintains periodic inspection of production of listed equipment or materials, and whose listing states either that the equipment or material meets nationally recognized standards or has been tested and found suitable for use in a specified manner. The means for identifying listed equipment may vary for each testing laboratory, inspection agency, or other organization concerned with product evaluation, some of which do not recognize equipment as listed unless it is also labeled. The plumbing official should utilize the system employed by the listing organization to identify a listed product.

LIQUID WASTE - the discharge from any fixture, appliance, or appurtenance, in connection with a plumbing system which does not receive fecal matter.

LOAD FACTOR - the percentage of the total connected fixture unit flow rate which is likely to occur at any point in the drainage system. It varies with the type of occupancy, the total flow unit above this point being considered, and with the probability factor of simultaneous use.

LOOP VENT - same as a circuit vent except that it loops back and connects with the stack vent instead of the vent stack.

MAIN - the principal artery of any system of continuous piping, to which branches may be connected.

MAIN SEWER - see Public Sewer.

MAIN VENT - the principal artery of the venting system, to which the vent branches may be connected.

MASTER PLUMBER - a natural person who possesses the necessary qualifications and knowledge to plan and lay out plumbing systems; who supervises journeyman plumbers in the installation, alteration and/or repair of plumbing systems and who is licensed as such by the Louisiana State Plumbing Board. [see LSA - R.S. 37:1377(A)]

MAY - the word "may" is a permissive term.

NONPOTABLE WATER - in addition to its ordinary meaning, includes water of questionable potability on the Louisiana State Plumbing Code, 2000 edition®

discharge side of a backflow preventer used to isolate a portion of a water supply system from the remainder of the water supply system due to backflow connections.

NUISANCE - public nuisance as known at common law or in equity jurisprudence; and whatever is dangerous to human life or detrimental to health; whatever building, structure, or premises is not sufficiently ventilated, sewerred, drained, cleaned, or lighted, in reference to its intended or actual use; and whatever renders the air or human food or drink or water supply unwholesome.

OFFSET - a combination of elbows or bends in a line of piping which brings one section of the pipe out of the line but into a line parallel with the other section.

PERMIT HOLDER - any person required to obtain a permit to do plumbing work in accordance with state, parish, city or other local laws or ordinances. (Where such permits are not available, the property owner, contractor and installer shall be jointly responsible for the installation being in compliance with the requirements of this Code and, where applicable, may all be considered permit holders as the term is used in this Code.)

PERSON - a natural person, his heirs, executors, administrators, or assigns; and includes a firm, partnership or corporation, its or their successors or assigns, the state of Louisiana or any of its political subdivisions, the United States government or any of its political subdivisions and any officer, employee and agent of one of those entities. Singular includes plural; male includes female.

PITCH - see Grade.

PLUMBING - the practice, materials and fixtures used in the installation, maintenance, extension and alteration of all piping fixtures, appliances and appurtenances in connection with any of the following: Sanitary drainage or storm drainage facilities, the venting system and the public or private water supply systems, within or adjacent to any building, structure or conveyance; also the practice and materials used in the installation, maintenance, extension or alteration of medical gas piping, medical vacuum piping, storm water, liquid waste or sewage, and water supply systems of any premises to their connection with any point of public disposal or other acceptable terminal. Plumbing does not include the installation, alteration, repair or maintenance of automatic sprinklers and their related appurtenances including standpipes when connected to automatic sprinklers and including the underground or overhead water supply beginning at the outlet of an approved backflow prevention device installed under the plumbing provisions of this code where water is to be used or is intended for use exclusively for fire protection purposes.

PLUMBING APPURTENANCE - manufactured device, or a prefabricated assembly, or an on-the-job assembly of component parts, which is an adjunct to the basic piping system and plumbing fixtures. An appurtenance demands no Louisiana State Plumbing Code, 2000 edition[®]

additional water supply, nor does it add any discharge load to a fixture or the drainage system. It is presumed that it performs some useful function in the operation, maintenance, servicing, economy, or safety of the plumbing system.

PLUMBING FIXTURES - are installed receptacles, devices, or appliances which are supplied with water or which receive or discharge liquids or liquid-borne wastes, with or without discharge into the drainage system with which they may be directly or indirectly connected.

PLUMBING INSPECTOR - see Plumbing Official.

PLUMBING OFFICIAL - the State Health Officer and any individual official, board, department or agency established and authorized by a state, parish, city or other political subdivision created by law to administer and enforce the provisions of the Plumbing Code as adopted or amended.

PLUMBING SYSTEM - includes the water-supply and distribution pipes; plumbing fixtures and traps; soil, waste and vent pipes; building drains and building sewers including their respective connections, devices and appurtenances within the property lines of the premises; water treating or water using equipment; and medical gas and medical vacuum piping and equipment.

POTABLE WATER - water having bacteriological, physical, radiological and chemical qualities that make it safe and suitable for human drinking, cooking and washing uses.

PRESSURE - the normal force exerted by a homogenous liquid or gas, per unit of area, on the wall of the container.

Pressure, Static - the pressure existing without any flow.

Pressure, Flowing - the residual pressure in the water supply pipe at the faucet or water outlet while the faucet or water outlet is wide open and flowing.

Pressure, Residual - the pressure available at the fixture or water outlet after allowance is made for pressure drop due to friction loss, head, meter and other losses in a system during maximum demand periods.

PRIVATE OR PRIVATE USE - in the classification of plumbing fixtures, private applies to fixtures in residences or apartments and similar installations where the fixtures are intended for the use of a family or an individual.

PRIVATE SEWER - a sewer privately owned and not directly controlled by public authority.

PUBLIC OR PUBLIC USE - in the classification of plumbing fixtures, public applies to fixtures in general, toilet rooms of schools, gymnasiums, hotels and motels, airports, bus and railroad stations, office buildings, public buildings, stadiums, department and mercantile stores, public comfort stations, bars, restaurants, commercial buildings or places to which the public is invited or which are frequented by the public without special permission or special invitation, and other installations (whether pay or free) where a number of fixtures are installed so that their use is similarly unrestricted.

PUBLIC SEWER - a common sewer directly controlled by public authority.

READILY ACCESSIBLE - having direct access without the need of removing any panel, door or similar covering of the item described and without requiring the use of portable ladders, chairs, etc. See Accessible.

RELIEF VENT - a vent whose primary function is to provide circulation of air between drainage and vent systems.

RESIDENTIAL BUILDINGS - buildings in which families or households live and in which cooking and sleeping accommodations are provided for each family or household unit independently, and in which no area within the building is used or occupied for any other purpose except that such buildings may have central washing facilities, as permitted in Chapter 4.

RETURN OFFSET - a double offset installed so as to return the pipe to its original alignment.

REVENT PIPE - that part of a vent pipe line which connects directly with an individual waste or group of wastes, underneath or in back of the fixture and extends either to the main or branch vent pipe. Sometimes called an individual vent.

RISER - a water supply pipe which extends vertically one full story or more to convey water to branches or fixtures.

ROOF DRAIN - a drain installed to receive water collecting on the surface of a roof and to discharge it into the leader (downspout).

ROUGHING-IN - the installation of all parts of the plumbing system which can be completed prior to the installation of fixtures. This includes drainage, water supply, and vent piping, and the necessary fixture supports.

SAND INTERCEPTOR - see Interceptor.

SANITARY - for or relating to the preservation or restoration of health; associated with measures or equipment for improving conditions that influence health; free from or effective in preventing or checking an agent injurious to health; a water closet, urinal, or similar equipment fitted with appropriate plumbing for the purpose of conducting wastewater to a point of collection and treatment prior to discharge.

SANITARY SEWER - a pipe which carries sewage and excludes storm, surface and ground water.

SCALD-PREVENTATIVE VALVE - (1) a pressure balancing valve which senses incoming hot and cold water pressures and compensates for fluctuations in either to stabilize outlet temperature; (2) a thermostatic valve which senses outlet temperature and compensates for fluctuations in incoming hot and cold water temperatures and pressures to stabilize outlet temperature; or (3) a combination

thermostatic/pressure balancing valve which senses outlet temperature and incoming hot and cold water pressures and compensates for fluctuations in incoming hot and cold water temperatures and pressures to stabilize outlet temperature.

SCUPPER - an opening in a wall or parapet that allows water to drain from a roof.

SEPARATOR - see Interceptor.

SEPTIC TANK - a watertight receptacle which receives the discharge of a drainage system or part thereof, and is designed and constructed so as to separate solids from the liquid, digest organic matter through a period of detention, and allow the liquids to discharge into the soil outside of the tank through a system of open-joint or perforated piping, or disposal pit.

SEWAGE - any liquid waste containing animal or vegetable matter in suspension or solution and may include liquids containing chemicals in solution.

SHALL - the word "shall" is a mandatory term.

SIDE VENT - a vent connecting to the drain pipe through a fitting at an angle not greater than 45 degrees (0.785 rad) to the vertical.

SLIP JOINT - a mechanical type joint used primarily on fixture traps: the joint tightness is obtained by compressing a friction type washer such as rubber, nylon, neoprene, lead or special packing material against the pipe by the tightening of a (slip) nut.

SLOPE - see Grade.

SOIL PIPE - any pipe which conveys the discharge of water closets or fixtures having similar functions, with or without the discharge from other fixtures, to the building drain or building sewer.

SOLVENT CEMENT - an adhesive (solvent) or mixture of adhesives which when applied to the surface of pipe and fittings will soften and fuse the plastic resin or compound of resins. Pipes and fittings are then joined causing the surfaces to unite forming a liquid tight joint.

SPECIAL WASTE PIPE - see Chapter 8.

SPILL-PROOF VACUUM BREAKER - an assembly consisting of one (1) check valve force-loaded closed and an air inlet valve force-loaded open to atmosphere, positioned downstream of the check valve.

STACK - the vertical main of a system of soil, waste or vent piping.

STACK GROUP - a term applied to the location of fixtures in relation to the stack so that by means of proper fittings, vents may be reduced to a minimum.

STACK VENT - the extension of a soil or waste stack above the highest horizontal drain connected to the stack. Sometimes called waste vent or soil vent.

STACK VENTING - a method of venting a fixture or fixtures through the soil or waste stack.

STATE HEALTH OFFICER - means the legally appointed and/or acting State Health Officer as defined in R.S. 40:2 and includes his/her duly authorized technical representative; however, in the case of variances allowed under section 105, this term shall mean the State Health Officer acting personally or any such person that the State Health Officer has personally designated to duly sign such variances in his/her behalf.

STORM DRAIN - see Building Storm Drain.

STORM SEWER - a sewer used for conveying rain water, surface water, condensate, cooling water or similar liquid wastes.

SUBSOIL DRAIN - a drain which receives only subsurface or seepage water and conveys it to a place of disposal.

SUMP - a tank or pit which receives sewage or liquid waste, located below the normal grade of the gravity system and which must be emptied by mechanical means.

SUPPORTS - supports, hangers and anchors are devices for supporting and securing pipe and fixtures to walls, ceilings, floors or structural members.

TRAILER TRAP - a device, fitting or assembly of fittings installed in the building sewer for a travel trailer or mobile/manufactured home which is used to prevent the circulation of air between the building sewer and the drainage system of the individual travel trailer or mobile/manufactured home.

TRAP - a fitting or device so designed and constructed as to provide, when properly vented, a liquid seal which will prevent the back passage of air without materially affecting the flow of sewage or waste water through it.

TRAP PRIMER - an approved device designed to deliver a sufficient amount of water to a seldom used trap.

TRAP SEAL - the maximum vertical depth of liquid that a trap will retain, measured between the crown weir and the top of the dip of the trap.

TRAP SEAL PRIMER VALVE (*see Trap Primer*)

UNSTABLE GROUND - earth that does not provide a uniform bearing for the barrel of the sewer pipe between the joints at the bottom of the pipe trench.

VACUUM BREAKER - a device which prevents back-siphonage of water by admitting atmospheric pressure through ports to the discharge side of the device.

VENT PIPE - see Vent System.

VENT STACK - a vertical vent pipe installed primarily for the purpose of providing circulation of air to and from any part of the drainage system.

VENT SYSTEM - a pipe or pipes installed to provide a flow of air to or from a drainage system or to provide a circulation of air within such system to protect trap seals from siphonage and back pressure.

VERTICAL PIPE - any pipe or fitting which is installed in a vertical position or which makes an angle of not more than 45 degrees (0.785 rad) with the vertical.

WASH RACK - a floor or slab area with floor drain used for cleaning containers and equipment exposed to organic wastes of food origin.

WASTE - see Liquid Waste and Industrial Wastes.

WASTE PIPE - a pipe which conveys only liquid waste, free of fecal matter.

WATER DISTRIBUTION PIPE - the piping within a building or structure which conveys cold or hot water from the water service pipe to the plumbing fixtures and other water outlets.

WATER HEATER - an appliance for supplying potable hot water for domestic or commercial purposes.

WATER MAIN - a water supply pipe or system of pipes, installed and maintained by a city, township, county or public utility company, on public property, in the street or approved dedicated easement for public or community use.

WATER OUTLET - as used in connection with the water distribution system, the discharge opening for the water (1) to a fixture; (2) to atmospheric pressure (except into an open tank which is part of the water supply system); (3) to a boiler or heating system; (4) to any water-operated device or equipment, but not a part of the plumbing system.

WATER RISER PIPE - see Riser.

WATER SERVICE PIPE - the pipe from the water main, water meter, water supply system or other approved source of water supply, to the building or structure served.

WATER SUPPLY SYSTEM - the water supply piping that is installed and maintained by the owner or owners on the premises or private property from the discharge side of the meter, the water main or other approved sources of water supply. This system includes the necessary connecting pipes, fittings, control valves, all appurtenances connected thereto, and includes fire protection piping if not installed as a separate system.

WET VENT - a vent which receives the discharge from wastes other than water closets.

YOKE VENT - a pipe connecting upward from a soil or waste stack to a vent stack for the purpose of preventing pressure changes in the stacks.

CHAPTER 3 GENERAL REGULATIONS

301 GENERAL

301.1 Scope

The provisions of this chapter shall govern the general regulations not specific to other chapters.

301.2 Basic Principles

The basic principles of this code are enunciated as basic goals in environmental sanitation worthy of accomplishment through properly designed, acceptably installed and adequately maintained plumbing systems. Some of the details of plumbing construction must vary, but the basic sanitary and safety principles are the same. The principles may serve to define the intent.

301.2.1 Principle Number 1 (moved from 601.2)

Buildings, structures and premises intended for human habitation, occupancy, use of employment, or the preparation or processing of food, drinks or other materials for human consumption shall be provided with an adequate, safe and potable water supply through a safe system of piping to all fixtures, appliances, appurtenances, etc.

301.2.2 Principle Number 2 (moved from 701.2)

Every building having plumbing fixtures installed and intended for human habitation, occupancy or use on premises abutting on a street, alley or easement in which there is a public sewer shall have a separate connection with the sewer.

301.2.3 Principle Number 3 (moved from 401.2)

A dwelling type building provided with a drainage system, a public sewer connection or a private sewage disposal system shall have at least one (1) water closet, one (1) bathtub or shower, one (1) lavatory, one (1) kitchen-type sink and an adequate source of hot water for each family unit to meet minimum basic requirements for health, sanitation and personal hygiene. Water heating facilities shall be accessible for emergency maintenance without entering any individual apartment or living unit, except that water heaters may be located within an apartment or living unit when supplying hot water to that unit only. All other buildings, structures or premises intended for human occupancy or use shall be provided with adequate sanitary facilities as may be required, but not less than one (1) water closet and one (1) lavatory.

301.2.4 Principle Number 4 (moved from 401.3)

Plumbing fixtures shall be made of smooth nonabsorbent material, shall be free from concealed fouling surfaces, and shall be located in ventilated enclosures.

301.2.5 Principle Number 5 (moved from 401.4)

Each fixture directly connected to the sanitary drainage system shall be equipped with a water-seal trap.

301.2.6 Principle Number 6 (moved from 301.3)

No substance which will clog the pipes, produce explosive mixtures, destroy the pipes or their joints or interfere unduly with the sewage-disposal process shall be allowed to enter the building drainage system.

301.2.7 Principle Number 7 (moved from 801.2)

Proper protection shall be provided to prevent contamination of food, water, sterile goods and similar materials by backflow of sewage. When necessary, the fixture, device or appliance shall be connected indirectly with the building drainage system.

301.2.8 Principle Number 8

No water closet shall be located in a room or compartment which is not properly lighted and ventilated.

301.2.9 Principle Number 9 (moved from 701.3)

If water closets or other plumbing fixtures are installed in buildings where there is no sewer within a reasonable distance, suitable provision shall be made for disposing of the building sewage by some accepted method of sewage treatment and disposal.

301.2.10 Principle Number 10 (moved from 701.4)

Where a plumbing drainage system may be subject to backflow of sewage, suitable provisions shall be made to prevent its overflow in the building.

301.2.11 Principle Number 11 (moved from 301.2)

Plumbing shall be installed with due regard to preservation of the strength of structural members and prevention of damage to walls and other surfaces through fixture usage.

301.2.12 Principle Number 12 (moved from 701.5)

Sewage or other waste, from a plumbing system, which may be deleterious to surface or subsurface waters shall not be discharged into the ground or into any waterway unless it has first been rendered innocuous through subjection to some acceptable form of treatment.

301.2.13 Principle Number 13 (moved from 601.3)

Plumbing fixtures, devices, appliances and appurtenances shall be adequately supplied with water in sufficient volume and pressure to enable them to function properly.

301.2.14 Principle Number 14 (moved from 601.4)

The pipes conveying water to plumbing fixtures, appliances, devices and appurtenances shall be of sufficient size as to supply water at rates that will prevent undue pressure drops at any one fixture, when any other fixture, appliance, device or appurtenance or group is being flushed, operated or used.

301.2.15 Principle Number 15 (moved from 601.5)

There shall be no direct or indirect cross connections, either existing or potential, between a safe potable water supply and an unsafe, nonpotable supply.

301.2.16 Principle Number 16 (moved from 601.6)

Adequate protection shall be provided to prevent possible backflow or back-siphonage of an unsafe or potentially hazardous fluid or material into a safe water supply.

301.2.17 Principle Number 17 (moved from 601.7)

Piping and connections of the plumbing system shall be of durable materials, free from defects in workmanship and materials, and systems shall be designed and constructed to provide adequate service for a reasonable life under stresses imposed by structural loading, temperature variation, vibration and other conditions.

301.2.18 Principle Number 18 (moved from 501.2)

Devices for heating and storing water shall be designed and installed to prevent all danger from overheating and explosion and to prevent undue flow of hot water or steam into the cold water supply pipes.

301.2.19 Principle Number 19 (moved from 801.3)

Refrigerators, coolers, receptacles, sterilizers, vats and similar equipment used for storing or holding foods, beverages, sterile goods and water conditioning equipment, etc., shall discharge into the building drainage system through an indirect waste.

301.2.20 Principle Number 20 (moved from 404.3)

Water closets, bathtubs, showers, urinals and similar fixtures shall be suitably enclosed and screened for privacy.

301.2.21 Principle Number 21 (moved from 301.4)

Plumbing systems, including fixtures, shall be maintained in sanitary condition and proper working order.

301.2.22 Principle Number 22 (moved from 701.3)

Sewage and wastes from plumbing and drainage systems shall be adequately treated and disposed of in accordance with the requirements of the plumbing official.

301.5 Repairs and Alterations

301.5.1 Existing Buildings. In existing buildings or premises in which plumbing installations are to be altered, repaired, or renovated, necessary deviations from the provisions of this code may be permitted, provided such deviations conform to the intent of the code and are approved in writing by the plumbing official.

301.5.2 Health or Safety. Wherever compliance with all the provisions of this code fails to eliminate or alleviate a nuisance which may involve health or safety hazards, the owner or his agent shall install such additional plumbing or drainage equipment as may be necessary to abate such nuisance.

301.6 Workmanship

Workmanship shall conform to generally accepted good practice.

301.7 Rodent-Proofing

301.7.1 Exterior Openings. All exterior openings provided for the passage of piping shall be properly sealed with snugly fitting collars of metal or other approved rodent-proof material securely fastened into place.

301.7.2 Interior Openings. Interior openings through walls, floors, and ceilings shall be rodent-proofed as found necessary by the plumbing official.

301.8 Used Equipment

It shall be unlawful to install used equipment or material for plumbing installations unless it complies with the minimum standards set forth in this code and is approved by the plumbing official.

301.9 Condemned Equipment

Any plumbing equipment condemned by the plumbing official because of wear, damage, defects, or sanitary hazards shall not be reused for plumbing purposes.

301.10 Drainage Below Sewer Level

Drainage piping located below the level of the sewer shall be installed in accordance with Chapter 7.

301.11 Connections to Plumbing System

301.11.1 Connections to Drainage System. All plumbing fixtures, drains, appurtenances and appliances used to receive or discharge liquid wastes or sewage shall be directly connected properly to the drainage system of the building or premises, in accordance with the requirements of this code. This section shall not be construed to prevent indirect waste systems provided for in Chapter 8.

301.11.2 Connections to Water Supply. Every plumbing fixture or device or appliance requiring or using water for its proper operation shall be directly or indirectly connected to the water supply system in accordance with the provisions of this code.

302 DEFINITIONS

The following definitions have been moved to Chapter 2: ANCHORS, HANGARS, LEAD FREE PIPE AND FITTINGS, LEAD FREE SOLDER AND FLUX.

303 MATERIALS

303.1 Minimum Standards

Materials listed in this section are applicable to more than one chapter. Material requirements for specific systems and fixtures are noted in the specific chapters. Materials listed in this code shall conform at least to the standards cited when used in the construction, installation, alteration, or repair of any part of a plumbing and drainage system, except that the

plumbing official shall allow the extension, addition, or relocation of existing soil, waste or vent pipes with materials of like grade, as permitted by this code.

303.2 Use of Materials

Where more than one standard is listed, the material shall conform to at least one of the standards cited opposite it. Its use shall be further governed by the requirements imposed in other chapters of the code. Materials not included in the table shall be used only as provided for in 303.1. Materials shall be free of manufacturing defects or damage, however occasioned, which would, or would tend to, render such materials defective, unsanitary, or otherwise improper to accomplish the purpose of this code.

303.3 Specifications for Materials

Standard specifications for general materials for plumbing installations are listed in Table 303, with specific material specifications listed elsewhere in this code. Products conforming at least to any one of the specifications listed for a given material shall be considered acceptable.

303.3.1 Abbreviations used in Table 303, and with the specific materials as listed elsewhere in this code refer to standards or specifications as identified below. Addresses are listed in 1403.

- AGA - American Gas Association
- ANSI - American National Standards Institute, Inc.
- ARI - Air-Conditioning & Refrigeration Institute
- ASME - American Society of Mechanical Engineers
- ASSE - American Society of Sanitary Engineering
- ASTM - American Society for Testing Materials
- AWS - American Welding Society
- AWWA - American Water Works Association
- CDA - Copper Development Association, Inc.
- CISPI - Cast Iron Soil Pipe Institute
- CAN/CSA - Canadian Standards Association
- FHA-MPS - Federal Housing Administration - Minimum Property Standards
- FMRC - Factory Mutual Research Corporation
- FS - Federal Specifications obtained from the General Services Administration, Federal Supply Service, Specification Section
- MSS - Manufacturers Standardization Society of the Valve and Fittings Industry, Inc.
- NFiPA - National Fire Prevention Association
- NSF - NSF International
- NSPI - National Spa and Pool Institute
- PDI - Plumbing and Drainage Institute
- PPFA - Plastic Pipe & Fittings Association
- PPI - Plastics Pipe Institute
- PS - Product Standard by the United States Department of Commerce and obtained from the Superintendent of Documents, Government Printing Office
- UL - Underwriters Laboratories, Inc.

303.3.2 ASTM Standards are issued under fixed designations; the final number shown in Chapter 14 indicates the year of original adoption, or in the case of

revision, the year of last revision. "T" indicates Tentative. In the "CS" series of standards, also, the final number indicates the year of issue.

Table 303
General Materials

MATERIALS	STANDARDS
PLASTIC MATERIALS	
Acetals	ASTM D 2133
Acrylics	ASTM D 788
Fluorocarbon	ASTM D 1457
Nylon	ASTM D 789
PLASTIC CEMENT AND SOLVENTS	
ABS-solvent cement	ASTM D 2235, Listed
Making solvent-cement joints with poly (vinyl chloride) (PVC) pipe and fittings	ASTM D 2855
Primers for use in solvent cemented joints of polyvinyl chloride (PVC) plastic pipe and fittings	ASTM F 656
PVC solvent cement	ASTM D 2564, Listed
Safe handling of solvent cements used for joining thermoplastic pipe and fittings	ASTM F 402
Solvent cements for chlorinated polyvinyl chloride (CPVC) plastic pipe and fittings	ASTM F 493
PLASTIC PIPE INSTALLATION	
Electrofusion joining polyolefin pipe and fittings	ASTM F 1290, See 612.5
Heat joining polyolefin pipe and fittings	ASTM D 2657, See 612.5
Underground installation of flexible thermoplastic sewer pipe	ASTM D 2321
Underground installation of thermoplastic pressure piping	ASTM D 2774
VALVES	
Pressurized fixture flushing devices (flushometers)	ANSI/ASSE 1037
METAL SHEET	
Brass, sheet	ASTM B 248
Copper, sheet	ASTM B 152
Lead, sheet	FS QQ-L-201F(2)
Steel sheet, zinc-coated galvanized by the hot-dip process	ASTM A 653/A 653M

(continued)

Table 303 (continued)
General Materials

MATERIALS	STANDARDS
MISCELLANEOUS	
Automatic flow controllers	ASSE 1028
Brazing filler metal	ASTM B 260
Cement lining	ANSI/AWWA C 104/A 21.4
Cleanouts (Metallic)	ASME A 112.36.2M
Coal-Tar Enamel and Tape (Protective Coating)	ANSI/AWWA C 203
Compression Gasket, C.I. Soil Pipe	ASTM C 564, CISPI HSN
Couplings used in Cast Iron Systems	ASTM C 564 (Gasket Material Only), CISPI 310, FMRC 1680 ASTM C 1277
Diverters for Plumbing Faucets with Hose Spray, Anti-Siphon Type Residential Application	ANSI/ASSE 1025
Drinking Water Treatment Units Health Effects	ANSI/NSF 53
Aesthetic Effects	ANSI/NSF 42
Fixed Flow Restrictors	ASSE 1034
Flexible Transition Couplings for Underground Piping Systems	ASTM C 1173
Floor Drains	ASME A 112.21.1M
Grooved and Shouldered Type Joints	ANSI/AWWA C606
Handheld Showers	ASSE 1014
Laboratory Faucet Vacuum Breaker	ASSE 1035
Liquid and Paste Fluxes for Soldering Applications of Copper and Copper Alloy Tube	ASTM B 813
Making Copper Soldered Joints	ASTM B 828
Oil Resistant Gaskets	ASTM C 443
Plastic Toilet (Water Closet) Seats	ANSI Z124.5
P.V.C. Transition Fittings, Testing	ASTM D 395, ASTM D 412, See 707.4
Reverse Osmosis Drinking Water Treatment Systems	ANSI/NSF 58
Roof Drains	ASME A112.21.2M
Rubber Rings for Asbestos Cement Pipe	ASTM D 1869, See 308.5
Solder Metal	ASTM B 32
Supports for Off-the-Floor Plumbing Fixtures for Public Use	ANSI A112.6.1M
Wall Hydrants, Frost Resistant, Automatic Draining, Anti-Backflow Type	ASSE 1019

303.4 Identification of Materials

Each length of pipe and each pipe fitting, trap, fixture and device used in a plumbing system shall be marked in accordance with the approved applicable standard to which it is manufactured.

303.5 Installation of Materials

All materials used shall be installed in strict accordance with the standards under which the materials are accepted and approved, including the appendices which are related to installation. In the absence of such installation procedures, the manufacturer's published procedures or recommendations shall be followed.

303.6 Water Piping Quality

All potable water pipes, pipe related products and materials that join or seal pipes and pipe related products shall be evaluated and listed as conforming with a national consensus product (or material) standard and ANSI/NSF Standard 61.

303.7 Special Materials

303.7.1 Lead. See Table 303. Sheet lead shall be not less than the following:

1. For safe pans - not less than 4 psf (19.5 kg/m²) coated with an asphalt paint or equivalent.
2. For flashings of vent terminals - not less than 3 psf (14.6 kg/m²).
3. Lead bends and lead traps shall be not less than 1/8-inch (3.18 mm) wall thickness.
4. Any pipe, solder or flux which is used in the installation or repair of any plumbing in a residential or nonresidential facility providing water for human consumption shall be lead free with not more than 0.2% lead in solders and flux and not more than 8.0% lead in pipes and fittings. This does not apply to leaded joints necessary for the repair of cast iron pipes.

303.7.2 Copper. Sheet copper shall be not less than the following:

1. Safe pans – 12 oz per sq ft (3.7 kg/m²).
2. Vent terminal flashings – 8 oz per sq ft (2.4 kg/m²).

303.7.3 Caulking Ferrules. Caulking ferrules shall be manufactured from bronze, wrought copper, or brass and shall be in accordance with Table 303.7.3.

Table 303.7.3
Caulking Ferrules

Pipe Size (In)	Inside Diameter (In)	Length (In)	Minimum Weight Each
2	2 1/4	4 1/2	1 lb 0 oz
3	3 1/4	4 1/2	1 lb 12 oz
4	4 1/4	4 1/2	2 lb 8 oz

1 in = 25.4 mm
1 lb = 0.4536kg

303.7.4 Soldering Bushings. Soldering bushings where permitted shall be of red brass in accordance with Table 303.7.4.

Table 303.7.4
Soldering Bushings

Pipe Size (In)	Minimum Weight Each
1 1/4	6 oz
1 1/2	8 oz
2	14 oz
2 1/2	1 lb 6 oz
3	2 lb 0 oz
4	3 lb 8 oz

1 in = 25.4 mm
1 lb = 0.4536 kg

303.7.5 Floor Flanges

303.7.5.1 Floor flanges for water closets or similar fixtures shall be not less than 1/8 inch (3.18 mm) thick for brass 1/4 inch (6.35 mm) thick and not less than 2-inch (51 mm) caulking depth for cast iron or galvanized

malleable iron. Flanges shall be of the approved type. Offset closet flanges shall be prohibited, except by approval of the plumbing official. Closet screws and bolts shall be of brass.

303.7.5.2 Flanges shall be soldered to lead bends, or shall be caulked, soldered or threaded to other metal. Plastic flanges shall be joined to plastic closet bends with the approved solvent cement.

303.7.6 Cleanouts

303.7.6.1 Cleanouts shall have plugs of brass and shall conform to ASTM A 74. Cleanouts may also have plugs of approved nylon plastic. Plugs may have raised square or countersunk heads, except countersunk head shall be used where raised heads may cause a hazard.

303.7.6.2 Cleanout plugs with borosilicate glass systems shall be of borosilicate glass.

303.7.7 Nonmetallic Shower Pans

303.7.7.1 Plasticized polyvinyl chloride (PVC) sheet shall be a minimum of 0.040 inch (1.02 mm) thick, and shall meet the requirements of ASTM D 4551. Sheets shall be joined by solvent welding in accordance with the manufacturer's published recommendations.

303.7.7.2 Nonplasticized chlorinated polyethylene sheet shall be a minimum 0.040 inch (1.02 mm) thick. Sheets shall be joined by solvent welding in accordance with the manufacturer's published recommendations, and shall meet the requirements of 303.8.3.

303.7.7.3 All shower pan material approved in Table 303 shall be permanently marked by the manufacturer so as to enable the inspecting authority to determine the acceptability of the material and its identification according to the code. This marking is to be conveniently readable to the inspector when the material is in its installed position.

303.8 Limitations of Use of Materials

★ 303.8.2 Plastic Pipe and Fittings Pressure Rated for Water Service Pipe

303.8.2.1 In Table 303 and Table 603, 4-digit numbers listed under "Materials" column represent the ASTM identification numbers assigned to these materials by the joint ASTM-NSF-PPI committee to assist in quick, easy identification of the materials. The numbers appear as a part of the marking on the pipe and tubing. These and no others are approved.

303.8.2.2 All plastic pipe and fittings approved in this code shall be properly marked as specified by their respective standards. All material shall be installed in accordance with the applicable ASTM standards. No materials shall be commingled within the same system except those which are specifically approved in writing in the respective standards.

303.8.2.3 Existing metallic water service piping used for electrical grounding shall not be replaced with nonmetallic pipe or tubing until other grounding means are provided which are satisfactory to the proper administrative authority having jurisdiction.

303.8.3 Plastic Pipe and Fittings for Drain, Wastes And Vents

303.8.3.1 Installations for plumbing drainage, waste and vents both above and below ground, indirect waste and storm drains shall conform to applicable standards listed in Table 303 and Table 703 and in conformity with Sections 706 and 707 of the Standard Building Code.

303.8.3.2 There shall be no commingling of different materials except through proper adapters. In all cases, approved solvent cement designated for the particular material shall be used.

303.8.3.3 Coextruded pipe with a cellular core and solid wall ABS DWV and PVC DWV plastic pipe shall be IPS Schedule 40 when used for drain, wastes and vents.

303.8.4 Stainless Steel Water Tube. Stainless steel water tube for above ground use shall conform to the standards listed in Table 603.

303.8.5 Plastic Pipe for Drains and Sewers

303.8.5.1 Coextruded PVC plastic pipe shall have a pipe stiffness of 25 (PS 25) when used for storm sewers, storm drains, foundation drains, and subsoil drains.

303.8.5.2 Coextruded PVC plastic pipe shall have a pipe stiffness of 50 (PS 50) when used for outside building sewers, storm drains, and storm sewers in accordance with 704.1, 1101.5, 1103.3 and 1103.4.

303.8.6 Plastic Piping Components and Related Materials. All plastic plumbing pipes, plastic plumbing piping components and related materials shall be listed as conforming with ANSI/NSF Standard 14.

304 PROTECTION OF PIPES

304.1 Breakage and Corrosion

Pipes passing under or through walls shall be protected from breakage. Pipes passing through concrete or cinder walls and floors or other corrosive material shall be protected against external corrosion by a protective sheathing or wrapping or other means that will withstand any reaction from lime and acid of concrete, cinder or other corrosive material. Sheathing or wrapping shall allow for expansion and contraction of piping to prevent any rubbing action. Minimum wall thickness of material is to be 0.025 inch (0.635 mm).

304.2 Sleeves

304.2.1 Annular spaces between sleeves and pipes shall be filled or tightly caulked as approved by the plumbing official.

304.2.2 Annular spaces between sleeves and pipes in fire rated assemblies shall be filled or tightly caulked in accordance with the Standard Building Code.

304.3 Pipes Through Footings or Foundation Walls

A soil pipe, waste pipe, or building drain that passes under a footing or through a foundation wall shall be provided with a relieving arch, or a pipe sleeve of schedule 40 pipe shall be built into the masonry wall. Such sleeve shall be two pipe sizes greater than the pipe passing through or as may be approved in writing by the plumbing official.

304.4 Minimum Depth of Water Piping Outside of Building

Water piping outside the building line shall be installed not less than 12 inches (305 mm) deep.

304.5 Trench Location

Trenching installed parallel to footings shall not extend below the 45° (0.785 rad) bearing plane of the footing or wall unless approved by the plumbing official.

304.6 Waterproofing of Openings

Joints at the roof, around vent pipes, shall be made watertight by the use of lead, copper, galvanized steel, aluminum, plastic or other approved flashings or flashing material. Exterior wall openings shall be made watertight.

304.7 Pipes in Wood Construction

Where cutting, notching, or boring occurs within 1 1/2 inches (38 mm) of the face of wooden joists, rafters, or studs, a protective steel plate 1/16 inch (1.59 mm) thick shall be used to protect the piping. The steel plate shall be the full width of the member and shall extend at least 2 inches (51 mm) on each side of the cut, bore, or notch.

EXCEPTION: A protective plate is not required for cast iron, galvanized or black steel, and Grade H stainless steel pipe.

305 TRENCHING, EXCAVATION AND BACKFILL

305.1 Support of Piping

Buried piping shall be supported throughout its entire length.

305.2 Open Trenches

All excavations required to be made for the installation of a building drainage system, or any part thereof within the walls of a building, shall be open trench work and shall be kept open until the piping has been inspected, tested and accepted.

305.3 Mechanical Excavation

Trenches shall be properly graded and tamped to support the load of the pipe installation.

305.4 Backfilling

Adequate precaution shall be taken to insure proper compactness of backfill around piping without damage to such piping. See Appendix I.

305.5 Tunneling

Where necessary, pipe may be installed by tunneling, jacking or a combination of both. In such cases, special care shall be exercised to protect the pipe from damage either during installation or from subsequent uneven loading. Where earth tunnels are used, adequate supporting structures shall be provided to prevent future settling or caving. Pipe may be installed in larger conduit which has been jacked through unexcavated portions of the trench.

305.6 Single Trench Prohibited

Water service pipes or any underground water pipes shall not be run or laid in the same trench as the building sewer or drainage piping, except as provided for in Chapters 6 and 7.

306 STRUCTURAL SAFETY

306.1 General

In the process of installing or repairing any part of a plumbing and drainage installation, the finished floors, walls, ceilings, tile work or any other part of the building or premises which must be changed or replaced shall be left in a safe structural condition in accordance with the requirements of the Standard Building Code.

306.2 Cutting, Notching and Boring

306.2.1 Notches on the ends of joists shall not exceed one-fourth the depth. Holes bored for pipes or cable shall not be within 2 inches (51 mm) of the top or bottom of the joist, and the diameter of any such hole shall not exceed one-third of the depth of the joist. Notches for pipes in the top or bottom of joists shall not exceed one-sixth of the depth and shall not be located in the middle one-third of the span.

306.2.2 In exterior walls and bearing partitions, any wood stud may be cut or notched to a depth not exceeding 25% of its width. Cutting or notching of studs to a depth not greater than 40% of the width of the stud is permitted in nonbearing partitions supporting no loads other than the weight of the partition.

306.2.3 A hole not greater in diameter than 40% of the stud width may be bored in any wood stud. Bored holes not greater than 60% of the width of the stud are permitted in nonbearing partitions or in any wall where each bored stud is doubled provided not more than two such successive double studs are so bored.

306.2.4 In no case shall the edge of the bored hole be nearer than 5/8 inch (15.9 mm) to the edge of the stud. Bored holes shall not be located at the same section of stud as a cut or notch.

307 FITTINGS

307.1 Change in Direction

307.1.1 Changes in direction in drainage piping shall be made by the appropriate use of 45° (0.785 rad) wyes, long-or-short-sweep quarter bends, one-sixth, one-eighth, or one-sixteenth bends, or by a combination of these or equivalent fittings. Single and double sanitary tees and quarter bends may be used in drainage lines only where the direction of flow is from the horizontal to the vertical.

307.1.2 Changes in direction in Schedule 40 DWV-PVC and ABS drainage piping shall be made by the appropriate use of 45° (0.785 rad) wyes, quarter bends or long sweep quarter bends, one-sixth, one-eighth, or one-sixteenth bends, or by a combination of these or equivalent fittings. Single and double sanitary tees and quarter bends may be used in drainage lines only where the direction of flow is from the horizontal to the vertical.

307.2 Short Sweeps

Short sweeps not less than 3-inch diameter may be used in soil and waste lines where the change in direction of flow is from the horizontal to the vertical and may be used for making necessary offsets between the ceiling and the next floor above.

307.3 Prohibited Fittings

A straight tee branch shall not be used as a drainage fitting. A saddle type fitting or running threads shall not be used in the drainage or vent system. Drainage or vent piping shall not be drilled or tapped unless approved by the plumbing official. A fitting having a hub in the direction opposite to flow shall not be used in the drainage system, unless the pipe is cut by either a saw or snap cutter, which will assure clean, smooth cuts of the pipe. Double sanitary tee pattern fittings shall not receive the discharge of fixtures or appliances with pumping action discharge.

307.4 Heel or Side Inlet Bend Prohibited

Heel or side inlet quarter bend fittings shall not be used in the drainage or vent system.

307.5 Obstruction to Flow

A fitting or connection which offers abnormal obstruction to flow shall not be permitted. See 709.

307.6 Increases and Reducers

Where different sizes of pipes or pipes and fittings are to be connected, the proper size increasers or reducers or reducing fittings shall be used between the two sizes.

308 TYPES OF JOINTS

308.1 Tightness

Joints and connections in the plumbing system shall be gastight and watertight for the pressure required by test, with the exceptions of those portions of perforated or open-joint piping which are installed for the purpose of collecting and conveying ground or seepage water to the underground storm drains.

308.2 Threaded Joints

Threaded joints shall conform to ASME B 1.20.1. All burrs shall be removed. Pipe ends shall be reamed or filed out to size of bore, and all chips shall be removed. Pipe-joint cement and sealing compound shall be used only on male threads and be insoluble and nontoxic. All pipe-joint sealants for use on potable water piping shall be listed and labeled by an approved testing laboratory.

308.3 Wiped Joints

Joints in lead pipe or fittings, or between lead pipe or fittings and brass or copper pipe, ferrules, solder nipples, or traps, shall be full-wiped joints. Wiped joints shall have an exposed surface on each side of a joint not less than 3/4 inch (19.1 mm) and at least as thick as the material being jointed. Wall or floor flange lead-wiped joints shall be made by using a lead ring or flange placed behind the joints at wall or floor. Joints between lead pipe and cast iron or steel shall be formed by means of a caulking ferrule, soldering nipple, or bushing.

308.4 Flexible Couplings

Flexible couplings may be used to join plain ends of similar or dissimilar pipes and the flexible coupling shall consist of an approved gasket that is attached to the pipe with special adjustable stainless steel clamps and bolts. (See 707.4.) The flexible couplings and the approved gasket shall be oil resistant.

308.5 Precast Joints

Precast collars shall be formed on the spigot and in the bell of the pipe in advance of use. Materials shall be resistant to acids, alkalies and oils, and precast joints shall conform to the requirements of ASTM C 425, and upon installation shall be tested as provided in this code.

308.6 Cement Mortar Joints and Connections

308.6.1 Except for repairs and connections to existing lines constructed with such joints, cement mortar joints are prohibited.

308.6.2 Where permitted, cement mortar joints shall be made in the following manner: A layer of jute or hemp shall be inserted into the base of the annular joint space and packed tightly to prevent mortar from entering the interior of the pipe or fitting. Not more than 25% of the annular space shall be used for jute or hemp. The remaining space shall be filled in one continuous operation with a thoroughly mixed mortar composed of one part cement and two parts sand, with only sufficient water to make the mixture workable by hand. Additional mortar of the same composition shall then be applied to form a one to one slope with the barrel of the pipe. The bell or hub of the pipe shall be swabbed to remove any mortar or other material which may have found its way into such pipe.

308.7 Burned Lead Joints

Burned (welded) lead joints shall be lapped and the lead shall be fused together to form a uniform weld at least as thick as the lead being jointed.

308.8 Joints for Plastic Pipe and Fittings

308.8.1 ABS and PVC pipe and fittings shall be solvent cemented using the proper cement recommended for the particular materials. All pipe cuts shall be square and both pipe and fittings shall be cleaned of all soil, dirt, oil and grease before applying primer or cement. Solvent joints made for pressure applications shall use primers and cements that are in compliance with the applicable ASTM standards. All solvent joints shall be made in accordance with the applicable ASTM standards and shall be allowed to dry before testing. Should any leak occur on water test, the defective joint shall be replaced. All solvent cements and primers shall comply with requirements of the ANSI/NSF 14 and shall be labeled to identify the laboratory certifying compliance for the particular cement and primer being used.

308.8.2 Plastic pipe and fittings for sewer and water pressure lines may also be joined by use of elastomeric joints when the respective standards for the materials so specify. Joints shall conform to the standards listed in either Table 603 or Table 703, as applicable, for elastomeric joints.

308.9 Grooved or Plain End Mechanical Couplings and Fittings

Grooved or plain end mechanical couplings and fittings may be used. Pipe is to be prepared in accordance with manufacturer's specifications.

308.10 Water Supply and Distribution Systems

Additional provisions for water supply and distribution systems are located in 612.

308.11 Sanitary Drainage Systems

Additional provisions for sanitary drainage systems are located in 706.

309 USE OF JOINTS

309.1 Threaded Pipe to Cast Iron

Joints between steel, brass, or copper pipe, and cast iron pipe shall be either caulked or threaded, formed as provided in 308.2 and 706.2, or shall be formed with approved adapter fittings.

309.2 Lead to Cast Iron or Steel

Joints between lead and cast iron or steel pipe shall be formed by means of wiped joints and a caulking ferrule, soldering nipple, or bushing as provided in 308.3.

309.3 Connection of Dissimilar Metals

There shall be no commingling of materials except through the use of proper fittings that make different kinds of metal pipe compatible.

309.4 Welding or Brazing

Brazing or welding shall be performed in accordance with requirements of recognized published standards of practice and by licensed or otherwise qualified mechanics. All brazing on medical gas systems shall be performed by certified

installers meeting the requirements of ASME Boiler and Pressure Vessel Code, Section IX, Welding and Brazing Qualifications, or ANSI/AWS B 2.2, Brazing Procedure and Performance Qualification, as referenced in Chapter 14.

309.5 Slip Joints

In drainage piping, slip joints may be used on both sides of the trap and in the trap seal. Slip joints in water piping may be used on the exposed fixture supply only.

309.6 Expansion Joints

Expansion joints must be accessible and may be used where necessary to provide for expansion and contraction of the pipes.

309.7 Mechanically Formed Tee Connections

309.7.1 Mechanically extracted collars shall be formed in a continuous operation consisting of drilling a pilot hole and drawing out the tube surface to form a collar having a height not less than three times the thickness of the tube wall.

309.7.2 The branch shall be notched to conform with the inner curve of the run tube and dimpled to insure that penetration of the branch tube into the collar is of sufficient depth for brazing and that the branch tube does not obstruct the flow in the main line tube.

309.7.3 All joints shall be brazed in accordance with 612.4. Soft soldered joints shall not be permitted.

310 HANGERS AND SUPPORTS

310.1 General

310.1.1 **Strains and Stresses.** Piping in a plumbing system shall be installed without undue strains or stresses and provision shall be made for expansion, contraction, and structural settlement.

310.1.2 **Material.** Hangers and anchors for support of pipe shall be of sufficient strength to maintain their proportionate share of the pipe alignment and to prevent sagging. Hangers shall be of a material which is compatible with the pipe and will not promote galvanic action.

310.1.3 **Attachment.** Hangers and anchors shall be securely attached to the building construction.

310.2 Vertical Piping

310.2.1 **Attachment.** Vertical piping shall be secured at sufficiently close intervals to keep the pipe in alignment and carry the weight of the pipe and contents.

310.2.2 **Cast Iron Soil Pipe.** Cast iron soil pipe shall be supported at the base and at each story level at intervals not exceeding 15 ft (4572 mm).

310.2.3 **Threaded Pipe.** Threaded pipe shall be supported

at the base and at not less than every other story at intervals not exceeding 30 ft (9144 mm).

310.2.4 Copper Tube. Copper tube shall be supported at each story for piping 1 1/2 inches and over and at not more than 4 ft (1219 mm) intervals for piping 1 1/4 inches and smaller.

310.2.5 Lead Pipe. Lead pipe shall be supported at intervals not exceeding 4 ft (1219 mm).

310.2.6 Plastic Pipe. Plastic piping shall be supported at each story for piping 2 inches or over and not more than 4 ft (1219 mm) intervals for piping 1 1/2 inches or under.

310.2.7 Borosilicate Glass Pipe. Borosilicate glass pipe shall be supported at every floor for 3-inch, 4-inch and 6-inch diameter vertical runs and at every other floor for sizes 2 inches and smaller. Padded riser clamps with 1/4 inch (6.35 mm) thick elastomer padding shall be used, restricting sideward as well as downward movement.

310.3 Horizontal Piping

310.3.1 Supports. Horizontal piping shall be supported at sufficiently close intervals to keep it in alignment and prevent sagging.

310.3.2 Cast Iron Soil Pipe. Cast iron soil pipe shall be supported at not more than 5 ft (1524 mm) intervals on 5 ft (1524 mm) lengths and 10 ft (3048 mm) intervals on 10 ft (3048 mm) lengths. Hangers shall be located as near hubs as possible.

310.3.3 Threaded Pipe. Threaded pipe shall be supported at approximate 12 ft (3658 mm) intervals.

310.3.4 Copper Tubing. Copper tube shall be supported at approximate 8 ft (2439 mm) intervals for tubing 1 inch and smaller and 10 ft (3048 mm) intervals for tubing 1 1/4 inches and larger.

310.3.5 Lead Pipe. Lead pipe shall be supported by strips or otherwise for its entire length.

310.3.6 Plastic Pipe. Plastic piping shall be supported at not more than 4 ft (1219 mm) intervals.

310.3.7 Borosilicate Glass Pipe. Borosilicate glass pipe shall be supported in horizontal runs every 8 to 10 ft (2438 to 3048 mm), never closer unless there are more than two joints in the 8 to 10 ft (2438 to 3048 mm) section. Padded hangers shall be used, of either the clevis or trapeze type.

310.4 Repair or Replacement

Piping in concrete or masonry walls or footings shall be placed or installed in chases or recesses which will permit access to the piping for repairs or replacement.

310.5 Base of Stacks

310.5.1 Supports. Bases of all soil stacks, waste and vent

stacks shall be supported to the satisfaction of the plumbing official.

310.5.2 Piping Material. Other piping material shall be so anchored as to take the load off the stack at the base.

311 TESTS

311.1 Required Tests

The permit holder shall make the applicable tests prescribed in 311.2 thru 311.5 to assure compliance with the provisions of this code. The permit holder shall give reasonable advance notice to the plumbing official when the plumbing work is ready for tests. The equipment, material, power, and labor necessary for the inspection and test shall be furnished by the permit holder and he is responsible for assuring that the work will withstand the test pressure prescribed in the following tests. All the piping of the plumbing system shall be tested with either water or air. After the plumbing fixtures have been set and their traps filled with water, the entire drainage system shall be submitted to final tests. The plumbing official may require the removal of any cleanouts to ascertain if the pressure has reached all parts of the system.

311.2 Drainage and Vent Tests

311.2.1 A water test shall be applied to the drainage system either in its entirety or in sections. If applied to the entire system, all openings in the piping shall be tightly closed, except the highest opening, and the system shall be filled with water to point of overflow. If the system is tested in sections, each opening shall be tightly plugged except the highest openings of the section under test, and each section shall be filled with water, but no section shall be tested with less than 10 ft head of water (29.9 kPa). In testing successive sections at least the upper 10 ft (3048 mm) of the next preceding section shall be tested, so that no joint or pipe in the building (except the uppermost 10 ft (3048 mm) of the system) shall have been submitted to a test of less than a 10 ft head of water (29.9 kPa). The water shall be kept in the system, or in the portion under test, for at least 15 minutes before inspection starts; the system shall then be tight at all points.

311.2.2 An air test shall be made by attaching an air compressor or testing apparatus to any suitable opening and, after closing all other inlets and outlets to the system, forcing air into the system until there is a uniform gage pressure of 5 psi (34.5 kPa) or sufficient to balance a column of mercury ten inches in height (33.8 kPa). This pressure shall be held without introduction of additional air for a period of at least 15 minutes.

EXCEPTION: Cast iron soil pipe joined with compression gaskets or mechanical couplings shall be tested with 6 psi (41.4 kPa) of air and allowed a 1 psi (6.9 kPa) reduction in pressure or a two inch (50.8 mm) drop in the column of mercury in a 15 minute period.

311.2.3 The final test of the completed drainage and vent system shall be visual and in sufficient detail to assure that

the provisions of this code have been complied with. provided, however, that, for cause, it may be necessary to subject the plumbing to either a smoke or peppermint test. Where the smoke test is preferred, it shall be made by filling all traps with water and then introducing into the entire system a pungent, thick smoke produced by one or more smoke machines. When the smoke appears at stack openings on the roof, they shall be closed and a pressure equivalent to a 1-inch water column (248.8 Pa) shall be maintained for 15 minutes before inspection starts. Where the peppermint test is preferred, 2 oz (59 mL) of oil of peppermint shall be introduced for each stack.

311.3 Test of Water Supply System

Upon completion of a section or of the entire water supply system, it shall be tested and proved tight under a water pressure not less than 200 psi (1379 kPa). The water used for tests shall be obtained from a potable source of supply.

311.4 Test of Building Sewer

311.4.1 Gravity sewer tests shall consist of plugging the end of the building sewer at the point of connection with the public sewer, filling the building sewer with water, testing with not less than a 10 ft (3048 mm) head of water and maintaining such pressure until backfill is completed.

311.4.2 Forced sewer tests shall consist of plugging the end of the building sewer at the point of connection with the public sewer and applying a pressure of 5 psi (34.5 kPa) greater than the pump rating, and maintaining such pressure until backfill is completed.

311.5 Test of Interior Leaders or Downspouts

Leaders or downspouts and branches within a building shall be tested by water or air in accordance with 311.2.1 or 311.2.2.

311.6 Backflow Prevention Devices

Backflow prevention devices shall be tested in accordance with CAN/CSA B64.10 or ASSE 5010.

312 APPENDIX REFERENCES

Additional general provisions are contained in the following appendices:

Appendix B - Travel Trailers and Travel Trailer Parks;
Appendix C - Mobile/Manufactured Homes and Mobile/Manufactured Home Parks; and in Appendix G - Medical Facilities Plumbing Systems. These provisions are applicable only when they are referenced in the body of the code sections or when included in the adopting ordinance.

CHAPTER 4 PLUMBING FIXTURES

401 GENERAL

401.1 Scope

The provisions of this chapter shall govern the materials, design, installation, and quality of fixtures.

★ 401.5 Prohibited Fixtures and Connections

401.5.1 Fixtures. Pan, valve, plunger, offset, washout, latrine, frostproof and other water closets having an invisible seal or an unventilated space or having walls which are not thoroughly washed at each discharge, and floor type trough urinals shall be prohibited. Any water closet which might permit siphonage of the contents of the bowl back into the tank shall be prohibited (for example, low down tank type water closets, etc.).

401.5.2 Connections. Fixtures having concealed slip-joint connections shall be provided with an access panel or utility space so arranged as to make the slip connections accessible for inspection and repair.

401.5.3 Limited Access. When access to waste and overflow fittings cannot be provided as required for slip joints in 401.5.2 or when bathtubs are set head-to-head, joints complying with 612.2 may be used. In such limited access cases, waste and overflow shall be of the straight-through type with overflow connecting to the tee branch which will allow the fixture, drain, and trap to be cleaned without disturbing concealed joints. Connections shall be inspected prior to concealment.

402 DEFINITIONS

The following definitions have been moved to Chapter 2: PRIVATE OR PRIVATE USE, PUBLIC OR PUBLIC USE.

403 INSTALLATION

403.1 Cleaning

Plumbing fixtures shall be installed in a manner to afford easy access for cleaning. Where practical, all pipes from fixtures shall be run to the nearest wall.

403.2 Joints

Where a fixture comes in contact with a wall or floor, the joint shall be watertight.

403.3 Wall-Hung Bowls

Wall-hung water closet bowls shall be rigidly supported by a concealed metal supporting member so that no strain is transmitted to the closet connection.

403.4 Setting

Fixtures shall be set level and in proper alignment with reference to adjacent walls. No water closet or bidet shall be set closer than 15 inches (381 mm) from its center to any side wall or partition nor closer than 30 inches (762 mm) center-Louisiana State Plumbing Code, 2000 edition®

to-center with adjacent fixtures. No urinal shall be set closer than 12 inches (305 mm) from its center to any side wall or partition nor closer than 24 inches (610 mm) center-to-center with adjacent urinal fixtures. See 708.

403.5 Sanitation

All public toilet room floor surfaces shall be of non-absorbent, impervious material.

404 LOCATION OF FIXTURES

404.1 Light and Ventilation

404.1.1 Means of Ventilation

404.1.1.1 Every restroom, bathroom or water closet combination shall be provided with ventilation by one or more operable windows opening to the outside of the building, by mechanical exhaust or by other means approved by the administrative authority.

404.1.1.2 When an operable window opening to the outside of the building is used for ventilation, an insect mesh screen shall be installed on such opening.

404.1.1.3 Public restrooms, bathrooms or water closet combinations shall be provided with ventilation by mechanical exhaust. When separate facilities for employees or staff of food service establishments, markets and retail food stores are provided, such facilities shall also be provided with ventilation by mechanical exhaust.

404.1.2 Combustion Chambers

The combustion chambers of all heaters, heating systems and other fired equipment shall be vented to the atmosphere. Other parts of the heating, cooling and ventilating system shall be so designed, built and maintained as to ensure that the pressure in the space from which combustion air is drawn does not become negative with respect to the atmosphere.

404.1.3 Mechanical Exhaust

All restrooms, bathrooms and water closet combinations which are ventilated by mechanical exhaust shall have fixed openings from adjacent room or corridors or from other approved sources, large enough to provide a sufficient inflow of air to make exhaust ventilation effective. Ventilation ducts from restrooms, bathrooms and water closet combinations shall be exhausted to the outside air or be connected into an independent system that exhausts to the outside air.

404.1.4 Illumination Level

Artificial lighting shall be installed in every restroom, bathroom or water closet combination sufficient to provide an illumination level of at least ten foot-candles, measured three feet off of the floor.

404.1.5 Partitions

Where a water closet is completely enclosed by partitions, such enclosure shall be separately lighted and ventilated.

404.2 Improper Location

Piping, fixtures or equipment shall not be located in such a manner as to interfere with the normal operation of windows, doors or other exit openings. Toilet rooms for public use shall not open directly into a room for the preparation of food for service to the public.

404.3 Toilet Facilities for Construction Workers

Toilet facilities, of the type and in the quantity approved by the administrative authority, shall be provided and maintained in a sanitary condition for the use of workmen during construction.

405 MATERIALS AND PERFORMANCE STANDARDS

Plumbing fixtures shall be constructed from approved materials, have smooth impervious surfaces, be free from defects and concealed fouling surfaces. Except as permitted elsewhere in this code, plumbing fixtures shall conform to the standards listed in Table 405, other than maximum flow limitations.

Table 405
General Fixtures and Accessories

MATERIALS	STANDARDS
Plumbing Fixture Fittings	ASME A112.18.1M
Flexible Water Connectors	ASME A112.18.6
Fixtures, Enameled Cast Iron Plumbing	ASME A112.19.1M
Fixtures, Non-Vitreous Ceramic (Fireclay)	ASME A112.19.9M
Fixtures, Vitreous China Plumbing	ASME A112.19.2M
Fixtures, Hydraulic Performance for Water Closets and Urinals	ASME A112.19.6
Fixtures, Stainless Steel Plumbing (Designed for Residential Use)	ASME A112.19.3M
Porcelain Enameled Formed Steel Plumbing Fixture	ASME A112.19.4M
Fixtures, Plumbing (for) Land Use, including Fixtures for Medical and Dental Facilities	FS WW-P-541 E/GEN(1)
Fixture-Setting Compound	FS HH-C-536c
Lead, Caulking	FS QQ-L-156
Plastic Bathtub Units	ANSI Z124.1
Plastic Lavatories	ANSI Z124.3
Plastic Sinks	ANSI Z124.6
Plastic Water Closet Bowls and Tanks	ANSI Z124.4
Trim for Water Closet Bowls, Tanks and Urinals	ASME A112.19.5
Water Hammer Arresters	ASSE 1010

406 WATER CONSERVATION

Plumbing fixtures and plumbing fixture fittings should conform to the following requirements.

1. All faucets, showerheads and their packaging should be marked by the manufacturer in accordance with the provisions of ASME Standard A 112.18.1M listed in Table 405. Water closets and urinals and their packaging should be marked in accordance with the provisions of ASME A 112.19.2M listed in Table 405.
2. New or replacement water closets, and urinals, should not be installed with a flow rate or flush volume in excess of the maximum specified in Table 406, when tested in accordance with the provisions of the applicable ASME Standard listed in Table 405.

Table 406
Maximum Allowable
Water Usage For Plumbing Fixtures¹

Water closets, flushometer tank or close-coupled 2-piece gravity-flush type	1.6 gal/flush
Water closets, one-piece	1.6 gal/flush
Water closets, nonresidential application	3.5 gal/flush
Urinals	1.0 gal/flush

1 gpm = 0.0631 L/s

1 gallon = 3.7854 L

Note:

1. Maximum allowable water usage for plumbing fixtures and fixture fittings not listed in this table should conform to the applicable ANSI or ASME standard listed in Table 405. Blowout fixtures, panelwear, clinic sinks and service sinks shall be exempted from these limitations.

407 MINIMUM PLUMBING FIXTURES

407.1 General

407.1.1 Restroom Plumbing Fixtures. Notwithstanding the provisions of section 1:011(b) of the Louisiana State Sanitary Code, in new construction, substantial renovation or building additions and in changes of occupancy classification or real property ownership, at least the minimum type(s) of rest room plumbing fixtures provided for in this section shall be installed, and the minimum number of each type of restroom plumbing fixture shall be in accordance with Table 407. The term "substantial renovation" as used 407.1.1 includes, but is not limited to, a renovation/operational change which would trigger the need, pursuant to the requirements of Table 407, for additional restroom plumbing fixtures to be installed, even if the occupancy classification itself may not have changed.

407.1.2 Non-Restroom Plumbing Fixtures. Where the construction of buildings and facilities was approved by the State Health Officer pursuant to Sanitary Code requirements then in effect, upgrading of such buildings and facilities to comply with the non-restroom plumbing fixture requirements of Table 407 shall not be required except where:

1. substantial renovation or building additions are undertaken, or
2. where the occupant or real property ownership thereof or the occupancy classification located therein changes subsequent to the effective date hereof, or
3. where a serious health threat to the public health exists, unless otherwise specifically provided hereinafter.

The term "substantial renovation" as used in 407.1.2 includes, but is not limited to, a renovation/operational change which would trigger the need, pursuant to the requirements of Table 407, for additional non-restroom plumbing fixtures to be installed, even if the occupant or the occupancy classification itself may not have changed.

407.1.3 Except as may be otherwise specifically noted within Table 407, the number of occupants of a building shall be determined by the square feet of usable floor space. In determining the usable floor space, the square foot area of permanent structural building components, food service establishment kitchens, toilet rooms, corridors, stairways, vertical shafts and equipment rooms, when necessary for the operation of building utilities only, may be deducted from the total aggregate floor area.

407.1.4 Tenancies, rental units or other usable areas within a building when separated from the required toilet facilities by walls or partitions without common access openings shall be considered independently from the remainder of the building and shall be provided with separate facilities in accordance with this chapter regardless of the type of occupancy.

407.1.5 In self-storage (mini-warehouse) complexes, facilities shall not be required in each building, but shall be located at the office or entrance and such that the plumbing official determines the intent of the code is satisfied (see 407.2).

407.2 Table 407 — General

407.2.1 In applying the schedule of facilities recorded in Table 407, consideration must be given to the accessibility of the fixtures. Conformity purely on a numerical basis may not result in an installation suitable to the need of the individual establishment. For example, schools should be provided with toilet facilities on each floor having classrooms.

407.2.2 Every building and each subdivision thereof intended for public use shall be provided with facilities in accordance with this chapter. Required facilities shall be directly accessible to the public through direct openings or

corridors from the area or areas they are intended to serve. Required facilities shall be free and designated by legible signs for each sex. Pay facilities may be installed when in excess of the required minimum facilities.

**Table 407
Minimum Plumbing Fixtures¹**

Building or Occupancy ²	Occupant Content ²	Water Closets ³			Lavatories ⁴			Bathtubs, Showers and Miscellaneous Fixtures	
Dwelling or Apt. House	Not Applicable	1 for each dwelling or dwelling unit			1 for each dwelling or dwelling unit			Washing machine connection per unit ⁵ . Bathtub or shower - one per dwelling or dwelling unit. Kitchen sink - one per dwelling or dwelling unit.	
Schools: Licensed Pre-School, Day Care or Nursery	Maximum Daily Attendance	Children (total)	Fixtures		To be provided in the same proportions as the number of water closets required			Kitchen: Children (total)	
		Age 0-4 years			Kitchen:			7-15 3 compartment sink (or approved domestic or commercial dishwashing machine and a 2 compartment sink) ¹⁸	
		1-20	1		1 in each food preparation and utensil washing area located to permit convenient use by all food and utensil handlers.			16-up 3 compartment sink (dishwashing machine, if provided, must be a commercial type) ¹⁸	
		21-40	2		Caring for Infants: 1 in or adjacent to each diaper changing area but never to be located in a food preparation/storage or utensil washing area.			One laundry tray, service sink, or curbed cleaning facility with floor drain on premises for cleaning of mops/mop water disposal.	
		41-80	3						
		For each additional 40 children over 80, add	1					Caring for Infants: One extra laundry tray, service sink, or similar fixture is required to clean and sanitize toilet training potties immediately after each use. Such fixture shall be dedicated solely for this purpose and shall not be in the food preparation/storage, utensil washing, or dining areas.	
		Age 5 years and above							
			Male	Female					
		1-40	1	1					
		41-80	1	2					
		81-120	2	3					
		121-160	2	4					
		For each additional 40 females over 160, add	1						
		For each additional 80 males over 160, add	1						
Schools: Elementary & Secondary	Maximum Daily Attendance	Persons (total)	Male	Female	Persons (total)	Male	Female	One drinking fountain for each 3 classrooms, but not less than one each floor	
		1-50	2	2	1-120	1	1		
		51-100	3	3	121-240	2	2		
		101-150	4	4	For each additional 120 persons over 240, add	1	1		
		151-200	5	5					
		For each additional 50 persons over 200, add	1						
Office ⁶ and Public Buildings ²²	100 sq ft per person	Persons (total)	Male	Female	Persons (total)	Male	Female	Drinking Fountains Persons Fixtures	
		1-15	1	1	1-15	1	1	1-100	1
		16-35	1	2	16-35	1	2	101-250	2
		36-55	2	2	36-60	2	2	251-500	3
		56-100	2	3	61-125	2	3	No less than one fixture each floor subject to access.	
		101-150	3	4	For each additional 120 persons over 125, add	1	1.5 ⁷		
		For each additional 100 persons over 150, add	1						

(continued)

**Table 407
Minimum Plumbing Fixtures¹**

Building or Occupancy ²	Occupant Content ²	Water Closets ³			Lavatories ⁴			Bathtubs, Showers and Miscellaneous Fixtures	
		Persons (total)	Male	Female	Persons (total)	Male	Female	Persons	Drinking Fountains Fixtures
Common toilet facilities for areas of commercial buildings of multiple tenants ^{8,9,27}	Use the sq ft per person ratio applicable to the single type occupancy(s) occupying the greatest aggregate floor area (Consider separately each floor area of a divided floor)	1-50	2	2	1-15	1	1	1-50	1
		50-100	3	3	16-35	1	2	101-250	2
		101-150	4	4	36-60	2	2	251-500	3
		For each additional 100 persons over 150, add	1	1.5 ⁷	61-125	2	3	501-1000	4
					For each additional 120 persons over 125, add	1	1.5 ⁷	Not less than one fixture each floor subject to access.	
Retail Stores ^{6,20,23}	200 sq ft per person	1-35	1	1	1-15	1	1	1-100	1
		36-55	1	2	16-35	1	2	101-250	2
		56-80	2	3	36-60	1	3	251-500	3
		81-100	2	4	61-125	2	4	501-1000	4
		101-150	2	5	For each additional 200 persons over 125, add	1	1.75 ⁷	Not less than one fixture each floor subject to access.	
		For each additional 200 persons over 150, add	1	1.75 ⁷	<u>Retail Food Markets that also processes or packages meat or other food items:</u>		<u>All Retail Food Markets:</u>		
					1 in each food processing, packaging, and utensil washing area located to permit convenient use by all food and utensil handlers.		One laundry tray, service sink, or curbed cleaning facility with floor drain on premises for cleaning of mops/mop water disposal.		
					<u>Retail Food Markets that also processes or packages meat or other food items:</u>				
					3 compartment sink ¹⁸				
Restaurants/Food Service Establishments ^{6, 17, 23}	30 sq ft per person	1-50	1	1	1-150	1	1	1-100	1
		51-100	2	2	151-200	2	2	101-250	2
		101-200	3	3	201-400	3	3	251-500	3
		201-300	4	4	For each additional 200 persons over 400, add	1	1	<u>Kitchen:</u>	
		For each additional 200 persons over 300, add	1	2	<u>Kitchen:</u>			3 compartment sink (dishwashing machine, if provided, must be a commercial type) ¹⁸	
					1 in each food preparation and utensil washing area located to permit convenient use by all food and utensil handlers			<u>Other Fixtures:</u>	
						One laundry tray, service sink, or curbed cleaning facility with floor drain on premises for cleaning of mops/mop water disposal.			

(continued)

**Table 407
Minimum Plumbing Fixtures¹**

Building or Occupancy ²	Occupant Content ²	Water Closets ³			Lavatories ⁴			Bathtubs, Showers and Miscellaneous Fixtures	
		Persons (total)	Male	Female	Persons (total)	Male	Female	Drinking Fountains ¹⁴ Persons	Fixtures
Clubs, Lounges, and Restaurants/ Food Service Establishments with Club, or Lounge ^{17,23}	30 sq ft per person	1-25	1	1	1-150	1	1	1-100	1
		26-50	2	2	151-200	2	2	101-250	2
		51-100	3	3	201-400	3	3	251-500	3
		101-300	4	4	For each additional 200 persons over 400, add	1	1	Bar: 3 compartment sink (dishwashing machine, if provided, must be a commercial type) ¹⁸ Other Fixtures: One laundry tray, service sink, or curbed cleaning facility with floor drain on premises for cleaning of mops/mop water disposal.	
		For each additional 200 persons over 300, add	1	2					
			Bar: 1 in each drink preparation and utensil washing area located to permit convenient use by all drink and utensil handlers.						
Do it yourself Laundries ⁵	50 sq ft per person	Persons (total)	Male	Female	Persons (total)	Male	Female	One drinking fountain and one service sink.	
		1-50	1	1	1-100	1	1		
		51-100	1	2	101-200	2	2		
Beauty Shops, Barber Shops, Nail Salons, and Tanning Facilities ⁶	50 sq ft per person	Persons (total)	Male	Female	Persons (total)	Male	Female	One drinking fountain and one service sink or other utility sink.	
		1-35	1	1	1-75	1	1		
		36-75	1	2					
Heavy manufacturing, ¹⁰ warehouses ¹¹ , foundries, and similar establishments ^{12,13}	Occupant content per shift, substantiated by owner. Also see 407.3.2	Persons (total)	Male	Female	Persons (total)	Male ¹⁴	Female ¹⁴	One drinking fountain for each 75 persons. One shower for each 15 persons exposed to excessive heat or to skin contamination with poisonous, infectious, or irritating material.	
		1-10	1	1	1-15	1	1		
		11-25	2	1	16-35	2	1		
		26-50	3	1	36-60	3	1		
		51-75	4	1	61-90	4	1		
		76-100	5	1	91-125	5	1		
		For each additional 60 persons over 100, add	1	0.17	For each additional 100 persons over 125, add	1	0.17		
Light Mfg. ¹⁰ Light Warehousing ¹¹ and workshops, etc. ^{12,13}	Occupant content per shift, substantiated by owner. Also see 407.3.2	Persons (total)	Male	Female	Persons (total)	Male ¹⁴	Female ¹⁴	One drinking fountain for each 75 persons. One shower for each 15 persons exposed to excessive heat or to skin contamination with poisonous, infectious, or irritating material.	
		1-25	1	1	1-35	1	1		
		26-75	2	2	36-100	2	2		
		76-100	3	3	101-200	3	3		
		For each additional 60 persons over 100, add	1	1	For each additional 100 persons over 200, add	1	1		

(continued)

**Table 407
Minimum Plumbing Fixtures¹**

Building or Occupancy ²	Occupant Content ²	Water Closets ³			Lavatories ⁴			Bathtubs, Showers and Miscellaneous Fixtures	
		Persons (total)	Male ¹⁶	Female ¹⁶	Persons (total)	Male	Female	Persons	Fixtures
Dormitories ¹⁵	50 sq ft per person (calculated on sleeping area only)	1-10 11-30 31-100 For each additional 50 persons over 100, add	1 1 3 1	1 2 4 1	1-12 13-30 For each additional 30 persons over 30, add	1 2 1	1 2 1	One drinking fountain for each 75 persons. Washing machine may be used in lieu of laundry trays. ¹⁵ One shower or bathtub for each 8 persons. Over 150 persons add 1 shower or bathtub for each 20 persons.	
Places of Public Assembly without seats and Waiting Rooms at Transportation Terminals and Stations	70 sq ft per person (calculated from assembly area.) Other areas considered separately. (See Office or Public Buildings.)	Persons (total) 1-50 51-100 101-200 201-400 For each additional 250 persons over 400, add	2 3 4 5 1	2 3 4 5 2	Persons (total) 1-200 201-400 401-750 Over 750 persons, lavatories shall be required at a number equal to not less than 1/3 of total of required water closets and urinals.	1 2 3	1 2 3	Drinking Fountains Persons 1-100 101-350 Over 350 add one fixture for each 400.	Fixtures 1 2
Theaters, Auditoriums, Stadiums ²¹ , Arenas ²¹ , and Gymnasiums ²⁶	Use the number of seats as basis	Persons (total) 1-50 51-100 101-200 201-400 For each additional 250 persons over 400, add	2 3 4 5 1	2 3 4 5 2	Persons (total) 1-200 201-400 401-750 Over 750 persons, lavatories shall be required at a number equal to not less than 1/3 of total of required water closets and urinals.	1 2 3	1 2 3	Drinking Fountains Persons 1-100 101-350 Over 350 add one fixture for each 400.	Fixtures 1 2
Churches, Mosques, Synagogues, Temples, and other Places of Worship ²⁶	Use the number of seats as basis	Persons (total) 1-70 71-150 151-500 For each additional 500 persons over 500, add	1 2 3 1	1 2 3 1	Persons (total) 1-200 201-400 401-750 Over 750 persons, lavatories shall be required at a number equal to not less than 1/3 of total of required water closets and urinals.	1 2 3	1 2 3	Drinking Fountains Persons 1-100 101-350 Over 350 add one fixture for each 400.	Fixtures 1 2
Retail Fuel Stations (Along an Interstate highway when the station property is located within 1/2 mile of the nearest toe ²⁵ of the exit/entrance ramp) ²³	Use the number of Fueling Points ¹⁹ as the basis	Fueling Points 1-8 9-12 13 or more	1 2 2	1 2 3	Fueling Points 1-12 13 or more	1 1	1 2	Drinking Fountains Fueling Points 1-12 13 or more	Fixtures 1 2
Retail Fuel Stations not meeting above criteria ²³	Use the number of Fueling Points ¹⁹ as the initial basis	Fueling Points 1 or more	1	1	Fueling Points 1 or more	1	1	Drinking Fountains Fueling Points 1 or more	Fixtures 1
Other Miscellaneous Buildings or Occupancies ²⁸									

1 ft² = 0.0929 m²

Notes:

1. The figures shown are based upon one fixture being the minimum required for the number of persons indicated or any fraction thereof.
2. The occupant content and the number of required facilities for occupancies other than listed shall be determined by the plumbing official. Plumbing facilities in the occupancies or tenancies of similar use may be determined by the plumbing official from this table.
3. Urinals can be substituted for up to 1/2 of the required water closets.
4. Twenty-four linear inches (610 mm) of wash sink or 18 inches (457 mm) of a circular basin, when provided with water outlets for such space, shall be considered equivalent to 1 lavatory.
5. When central washing facilities are provided in lieu of washing machine connections in each living unit, central facilities shall be located for the building served at the ratio of not less than one washing machine for each 12 living units, but in no case less than two machines for each building of 15 living units or less. See 409.4.5.
6. With the exception of retail stores associated with retail fuel stations and/or restaurant/food service establishments associated with retail fuel stations and retail stores that require 2 or more different food permits (see note #20 below), a single facility consisting of one water closet and one lavatory may be used by both males and females in the following occupancies subject to the building area limitations:

Occupancy	Total Building Area (sq ft)
Office	1200
Retail Store (within covered mall)	3500
Laundries (Self-Service)	1400
Beauty Shops, Barber Shops, Tanning Facilities, and Nail Salons	900

Occupancy	Usable Building Area (sq ft)
Restaurant/Food Service Establishment (excluding retail fuel stations)	500
Retail Store (excluding retail fuel stations)	1500

7. After totaling fixtures, round up any fraction to the next highest whole number of fixtures.
8. Common toilet facilities (separate for males and females) for each floor are acceptable in lieu of separate facilities required by this section only when the applicable building occupant content has common access from within the building. When tenancies, rental units, etc., are to be provided with separate facilities of a partial nature, such facilities are not deductible from the total common facilities required.
9. (a) Applicable to small stand-up restaurants and similar occupancies.
(b) Not applicable to do-it-yourself laundries, beauty shops and similar occupancies where persons must remain to receive personal services.
10. (a) Light manufacturing is applicable to those manufacturers manufacturing finished products which require no special equipment to handle single finished products but may require special equipment to handle the products when packaged in containers containing multiple products.
(b) Heavy manufacturing is applicable to those manufacturing processes requiring overhead cranes or similar equipment for the movement of raw materials and/or the finished products.
11. (a) Light Storage: Light storage is the storage of items which can be handled without the aid of special handling equipment such as cranes, forklifts or similar equipment.
(b) Heavy Storage: Heavy storage is the storage of items which require special equipment for handling such as cranes, forklifts or similar equipment.
12. For other than industrial areas of the occupancy, see other applicable type occupancies (applicable to facilities provided due to inaccessibility of those in main or initial occupancy).
13. As required by the Minimum Requirements for Sanitation in Places of Employment (ANSI Z4.1).
14. Where there is exposure to skin contamination with poisonous, infectious, or irritating materials, provide 1 lavatory for each 15 persons.
15. Laundry trays, 1 for each 50 persons. Service sinks, 1 for each 100 persons.
16. For exclusively male or female dorms, the fixtures shall be double the amount required for the particular gender in a co-ed dorm.
17. If alcoholic beverages are to be served, facilities shall be as required for clubs or lounges.
18. At the discretion of the Plumbing Official, one properly sized grease trap for wastewater from the kitchen utensil washing sink(s), dishwashing machine(s), etc., is also required.
19. Fueling point means the number of fueling hoses which may be activated simultaneously while refueling automobiles or other motor vehicles.
20. Retail stores, regardless of the size of the building area, which require two or more different food permits (e.g., Grocery Permit, Restaurant Permit, etc.) shall be required to provide no less than a minimum of two facilities consisting of one water closet and one lavatory each.
21. a.) Trough urinals may only be used for stadiums, arenas, and jails, prisons, or other institutions of detention or incarceration. Trough urinals, when used, shall conform to the following requirements: They shall not be less than 6 inches deep and shall be furnished with one piece backs and have strainers with outlets at least 1 1/2 inches in diameter. The washdown pipe shall be perforated so as to flush with an even curtain of water against the back of the urinal. This pipe shall be securely clamped as high as practicable to the back of the urinal. Trough urinals, where so equipped, shall have tanks with a flushing capacity of not less than 1 1/2 gallons of water for each 2 feet of urinal length.
b.) Trough urinals shall be figured on the basis of one (1) urinal for each 18 inches of length, provided that: 24-inch urinal equals 1 urinal; 36-inch urinal equals 2 urinals; 48-inch urinal equals 3 urinals; 60-inch urinal equals 4 urinals; and a 72-inch urinal equals 4 urinals.
c.) Privacy screens shall not be required for trough urinals.
22. Applies to educational occupancies above the 12th grade.
23. If building is a multi-purpose facility (i.e., a retail fuel station and a retail store, or a retail fuel station and a retail store and a restaurant, or a retail store and retail fuel station, etc.), the occupancy which requires the largest number of fixtures shall apply.
24. Drinking fountain requirement may be waived if drinking water is dispensed in an approved, sanitary manner in accord with the requirements of Chapter XXIII of the Louisiana State Sanitary Code.
25. "Toe" is defined as the point where the Interstate highway's exit/entrance ramp meets the intersecting highway.
26. For pew or bench type seating, each 18 inches of pew or bench shall equate to one (1) person.
27. Central facilities shall be installed such that the path of travel to such facilities shall not exceed a distance of 500 feet and such facilities shall be located not more than one story above or below the space required to be provided with toilet facilities. The maximum travel distance to the central toilet facilities shall be measured from the main entrance of any store or tenant space.
28. Refer to the following chapters of the Louisiana State Sanitary Code for specific information relative to the number of plumbing fixtures required for these other miscellaneous buildings or occupancies:

Building or Occupancy	Louisiana State Sanitary Code
Wholesale Seafood Plants (Marine and Freshwater)	Chapter IX
Campsites	Chapter XVI
Jails, Prisons and Other Institutions of Detention or Incarceration ²¹	Chapter XVIII
Hospitals, Ambulatory Surgical Centers, Renal Dialysis Centers	Chapter XIX
Nursing Homes	Chapter XX
Temporary Food Service (Festivals or Fairs)	Chapter XXIII
Swimming Pools	Chapter XXIV
Mass Gathering Areas	Chapter XXV

407.3 Adjustments to Minimum Facilities

407.3.1 The plumbing official may make adjustments in the distribution of facilities between male and female when furnished satisfactory data to substantiate a claim that the numbers of male and female fixtures in Table 407 would not provide a satisfactory ratio of facilities based on the male-female ratio for the ultimate users. In any case, where deviation is permitted, in accordance with this section, the plumbing official may require additional facilities if the data submitted proves to be in error or if changes are made that affect such data, whether it be by the original or later owner or occupants of the building or tenancy.

407.3.2 The plumbing official may make adjustments in the occupant content established by Table 407 when, in a particular case, satisfactory data, accompanied by plans, is furnished which substantiates a claim that the occupant content of a particular building or tenancy will, at all times, be less than provided for in the above table. Approval of such data and accompanying claims shall not prevent the plumbing official from requiring additional facilities based on the above table, should changes be made affecting the data or plan upon which the original approval was based whether such changes be made by the original or ultimate owner or building occupant or occupants. The remainder of the facilities' requirements of 407 are not affected by this paragraph.

407.4 Facilities' Separation

The occupant content established by this code shall not be construed to have any force or effect upon the occupant content requirements of the Standard Building Code and is established only to calculate the number of plumbing facilities required for a building or for a tenancy within a building when such tenancy is separated from the remainder of the building by walls or partitions or when central facilities would not provide for the satisfactory needs of a tenant's patrons who must remain in a given area to receive the service rendered.

408 FIXTURE OUTLETS

408.1 Lavatory Waste Outlets

Lavatories shall have waste outlets not less than 1 1/4-inch diameter. Waste outlets may have open strainers or may be provided with stoppers.

408.2 Sink Waste Outlets

Sinks shall be provided with waste outlets not less than 1 1/2-inch diameter. Waste outlets may have open strainers or may be provided with stoppers.

408.3 Strainers and Fixture Outlets

All plumbing fixtures, other than water closets and syphon-action washdown or blowout urinals, shall be provided with strainers having waterway area complying with Table 405.

408.4 Overflows

408.4.1 Design. When any fixture is provided with an overflow, the waste shall be so arranged that the standing water in the fixture cannot rise in the overflow when the stopper is closed or remain in the overflow when the fixture is empty.

408.4.2 Connection. The overflow pipe from a fixture shall be connected on the house or inlet side of the fixture trap, except that overflows of flush tanks may discharge into the water closets or urinals served by them, but it shall be unlawful to connect such overflows with any other part of the drainage system.

409 FIXTURE TYPES

409.1.1 Commercial Dishwashing Machines

409.1.1.1 Protection. Commercial dishwashing machines shall meet requirements of 606.

409.1.1.2 Waste Connection. Each unit may be separately trapped or discharge indirectly into a properly trapped and vented fixture. A commercial dishwashing machine shall not be directly connected to a drainage system. When a commercial dishwashing machine is located within five feet of a trapped floor drain, the dishwasher waste outlet may be connected directly on the inlet side of a properly vented floor drain trap.

409.1.1.3 Sanitization. Commercial dishwashing machines shall be installed and operated in accord with the manufacturer's recommendations and with the mechanical cleaning and sanitizing requirements contained within Chapter XXIII (Eating and Drinking Establishments) of the Louisiana State Sanitary Code.

409.1.1.4 Flow Pressure. When spray-type dishwashing machines are used in commercial installations, the pressure measured in the final rinse water line shall be at least 15 psi (103 kPa) and not more than 25 psi (172 kPa) when the final rinse spray is operating. A suitable pressure gauge and gage cock shall be provided in a readily accessible location immediately upstream from the final rinse sprays to permit checking the flow pressure of the final rinse water. If necessary, a permanently installed pressure regulator shall be provided on the final rinse water line in order to maintain the proper water pressure in the line when the final rinse spray is operating.

409.1.2 Domestic Dishwashing Machines

409.1.2.1 Protection. Domestic dishwashing machines shall meet requirements of 606.

409.1.2.2 Waste Connection. Each unit may be separately trapped or discharge indirectly into a properly trapped and vented fixture. A domestic dishwashing machine shall not be directly connected to a drainage system. It may be connected through a wye

connection into the tail piece of a sink or into the body of a disposal unit with the flexible dishwasher hose looped up to within 2 inches of the bottom of the counter top.

409.2 Drinking Fountains

409.2.1 Design and Construction. Drinking fountains shall conform to ASME A 112.19.2M if of vitreous china, ANSI/ARI 1010 if of the mechanically refrigerated type, or ASME A 112.1.2 if of the bubbler type.

409.2.2 Protection of Water Supply. Stream projectors shall be so assembled as to provide an orifice elevation as specified by ASME A 112.1.2.

409.2.3 Prohibited Location. Drinking fountains shall not be installed in public toilet rooms.

409.3 Garbage Can Washers

Garbage can washers shall be separately trapped. The receptacle receiving the wash from garbage cans shall be provided with a removable basket or strainer to prevent discharge of large particles into the building drainage system. Any water supply connection shall be protected against backflow by an air gap or a backflow prevention device.

409.4 Floor Drains

409.4.1 Installation

409.4.1.1 Floor drains shall be installed in all public toilet rooms, etc., (see definition of Public or Public Use in Chapter 2) except for hotel and motel guest rooms and patient rooms of hospitals and nursing homes. When floor drains are installed in the above mentioned rooms, the floor drains shall be not less than 2 inches and the trap shall be equipped with an approved trap primer to maintain the water seal in the floor drain trap. When a trap primer is connected to a potable water supply pipe, an approved backflow preventer shall be separately installed on the trap primer's individual supply line.

409.4.1.2 Floor drains shall connect into a trap so constructed that it can be readily cleaned and of a size to serve efficiently the purpose for which it is intended. The drain inlet shall be so located that it is, at all times, in full view.

409.4.1.3 Floor drains subject to backflow shall not be directly connected to the drainage system or shall be provided with a backwater valve.

409.4.1.4 Floor drain trap seals subject to evaporation shall be of the deep-seal type of not less than a 4-inch (102 mm) water seal or shall be fed from an approved plumbing fixture or by means of an approved automatic priming device designed and approved for that purpose.

409.4.1.5 Floor drain traps and drains shall be not less than 2-inch diameter.

409.4.2 Strainers. Floor drains shall be provided with removable strainers, the open area of which shall be not less than two-thirds of the cross-sectional area of the trap to which it connects.

409.4.4 Prohibited Location

409.4.4.1 No floor drain or other plumbing fixture except electric water heaters shall be installed in a room containing air handling machinery when such room is used as a plenum. When rooms are used as a plenum, equipment drains shall be conveyed through an indirect waste receptor located outside such rooms or other approved point of disposal. When such equipment rooms are not used as a plenum, floor drains may be installed if an approved trap primer is installed.

409.4.4.2 Floor drains directly connected to the plumbing system shall not be located in elevator pits.

409.4.4.3 No floor drains shall be permitted in food storage areas unless installed in accordance with Section 804.1.

409.4.4.4 Floor drains are not permitted in walk-in coolers or freezers unless they are provided with indirect connections to the sanitary sewer located outside the walk-in cooler or freezer.

409.4.5 Required Location and Construction

In public coin operated laundries and in the central washing facilities of apartment buildings or in rooms containing connections for laundry machines except in one and two family dwellings, the rooms containing the laundry machines shall be provided with adequate floor drains located to readily drain the entire floor area. Such drains shall have a minimum outlet cross section of not less than 2-inch diameter, and, except when such floor drains are embedded in concrete floors, the floors shall be treated as required by 409.8.2 for floors under shower compartments. Required floor drains shall meet the design criteria for shower drains in 409.8.1.

409.5 Food Waste Grinder Units

409.5.1 Separate Connections. Domestic food waste disposal units may be connected and trapped separately from any other fixture or compartment. Units may have either automatic or hand-operated water-supply control. See 606.

409.5.2 Commercial Type Grinders. Food grinders used in commercial buildings shall have an automatic water-supply and shall be provided with not less than 2-inch (51mm) waste line. Each waste line shall be trapped and vented as provided in other sections of this code. (see 1004.11)

409.6 Laundry Trays

409.6.1 Waste Outlets. Each compartment of a laundry tray shall be provided with a waste outlet not less than 1 1/2 inches in diameter.

409.6.2 Overflow. Laundry tray overflows shall conform to the requirements of 408.4.

409.7 Multiple Washsinks

409.7.1 Circular Type. Each 18 inches (457 mm) of wash sink circumference (circular type) shall be equivalent to one lavatory.

409.7.2 Straight-Line Type. Multiple wash sinks of the straight-line type shall have hot and cold combination spouts not closer than 18 inches (457 mm) from adjacent similar spouts and each spout shall be considered the equivalent of one lavatory.

409.8 Shower Compartments

409.8.1 Shower. Shower compartments shall conform to Table 409.8 and shall have approved shower pan material or the equivalent thereof as determined by the plumbing official. The pan shall turn up on three sides at least 2 inches (51 mm) above finished curb level. The remaining side shall wrap over the curb. Shower drains shall be constructed with a clamping device so that the pan may be securely fastened to the shower drain thereby making a watertight joint. Shower drains shall have an approved weephole device system to insure constant drainage of water from the shower pan to the sanitary drainage system. There shall be a watertight joint between the shower drain and trap. Shower receptacle waste outlets shall be not less than 2 inches and shall have a removable strainer.

EXCEPTION: Shower compartments with prefabricated receptors conforming to the standards listed in Table 409.8 or special use shower compartments for accessible use which comply with the ANSI A117.1 accessibility standard.

**Table 409.8
Prefabricated Shower Receptor Standards**

MATERIALS	STANDARDS
Plastic Shower Receptors and Shower Stalls	ANSI Z124.2
Shower Pans Nonmetallic	ASTM D 4551, See 303.7

409.8.2 Construction. Floors under shower compartments shall be laid on a smooth and structurally sound base and shall be lined and made watertight with sheet lead, copper or other acceptable materials.

409.8.3 Public or Institutional Showers. Floor of public shower rooms shall be drained in such a manner that no waste water from any shower head will pass over floor areas occupied by other bathers.

409.9 Special Fixtures

409.9.1 Water Drain and Connections. Baptistries, ornamental and lily pools, aquaria, ornamental fountain basins and similar constructions when provided with water supplies shall be protected from back-siphonage as required in 606.1.

409.9.2 Approval. Specialties requiring water and waste connections shall be submitted for approval of the plumbing official.

409.9.3 Accessible Fixtures. Accessible fixtures shall comply with the requirements of ANSI A117.1.

409.10 Swimming Pools, Spas, and Hot Tubs

409.10.1 Water circulation system components for swimming pools, spas or hot tubs shall meet the requirements of ANSI/NSF 50. The circulation system components are diatomite type filters, sand type filters, cartridge type filters, recessed automatic surface skimmers, centrifugal pumps of 7.5 horsepower (5.6 kW) or smaller, adjustable output rate chemical feeding equipment, multiport valves and flow-through chemical feeding equipment. [For other plumbing requirements, also see Chapter XXIV (Swimming Pools) - Louisiana State Sanitary Code]

409.10.2 Suction Fittings. Suction fittings shall conform to ASME A 112.19.8M. Public, Residential Spas shall comply with the standards listed in Table 409.10.

**Table 409.10
Public and Residential Spas Standards**

MATERIALS	STANDARDS
Public Spas	ANSI/NSPI 2
Residential Spas, Permanently Installed	ANSI/NSPI 3
Residential Spas, Portable	ANSI/NSPI 6

409.11 Urinals

409.11.1 Automatic Flushing Tank. Tanks flushing more than one urinal shall be automatic in operation and of sufficient capacity to provide the necessary volume to flush and properly cleanse all urinals simultaneously.

409.11.2 Urinals Equipped with Automatic Flush Valves. Flushometers shall be as prescribed in 409.13.5 and no valve shall be used to flush more than one urinal.

409.12 Washing Machines for Residences

409.12.1 Protection. Domestic washing machines shall meet the requirements of 606.1.

409.12.2 Separate Trap. Each unit shall be separately trapped or discharge indirectly into a properly trapped and vented fixture. (see 1001.9)

409.12.3 Cross Fittings. Automatic washing machines shall not be connected to a 2-inch or smaller cross type fitting.

409.13 Water Closets

409.13.1 Public Use. Water closet bowls for public use shall be of the elongated type.

409.13.2 Flushing Device. Water closet gravity, tanks, flushometer tanks and flushometer valves shall have a flushing capacity sufficient to properly flush the water closet bowls to which they are connected.

409.13.3 Float Valves. Float valves in water closet tanks shall close tight and provide water to properly refill the trap seal in the bowl.

409.13.4 Close-Coupled Tanks. The flush valve seat in close-coupled water closet combinations shall be 1 inch (25.4 mm) or more above the rim of the bowl, so that the flush valve will close even if the closet trapway is clogged. Any closets with flush valve seats below the rim of the bowl shall be so constructed that in case of trap stoppage, water will not flow continuously over the rim of the bowl.

409.13.5 Automatic Flush Valve. Flushometers shall be so installed that they will be readily accessible for repairing. When the valve is operated, it shall complete the cycle of operation automatically, opening fully and closing positively under the service pressure. At each operation, the valve shall deliver water in sufficient volume and at a rate that will thoroughly flush the fixture and refill the fixture trap. Means shall be provided for regulating flush valve flow. Not more than one fixture shall be served by a single flush valve.

409.13.6 Seats. Water closets shall be equipped with seats of smooth nonabsorbent material. All seats of water closets provided for public use shall be of the open-front type. Integral water closet seats shall be of the same material as the fixture. The seat contour shall be the same contour as the water closet.

409.14 Whirlpool Bathtubs

409.14.1 Access. An access panel of sufficient size shall be installed to provide access to the pump for repair and replacement.

409.14.2 Pump. When not factory assembled to the tub assembly, the circulation pump shall be accessibly located above the crown weir of the trap. The pump drain line shall be properly graded to assure minimum water retention in the volute after fixture use.

409.14.3 Operation. Leak testing and pump operation shall be performed in accordance with manufacturer's recommendations.

409.14.4 Hydromassage Bathtubs. Hydromassage bathtubs shall comply with UL 1795.

409.14.5 Whirlpool Bathtub Appliances. Whirlpool bathtub appliances shall comply with ASME A 112.19.7M.

409.14.6 Suction Fittings. Suction fittings for use in whirlpool bathtubs shall comply with ASME A 112.19.8M.

410 APPENDIX REFERENCES

Additional provisions for plumbing fixtures are contained in Appendix G - Medical Facilities Plumbing Systems. These provisions are applicable only when they are referenced in the body of the code sections or when included in the adopting ordinance.

CHAPTER 5 WATER HEATERS

501 GENERAL

501.1 Scope

The provisions of this chapter shall govern the materials, design, and installation of water heaters.

★

501.3 Working Pressure Identification

All storage tanks and water heaters shall be clearly and indelibly marked showing the allowable safe working pressure.

501.4 Water Heater As Space Heater

A water heater may be used as a part of a space heating system if the outlet water temperature of the water heater does not exceed 160°F (71°C) and the potability of the water is maintained throughout the system.

501.5 Sediment Drains

A suitable water valve or cock, through which sediment may be drawn off or the heater or tank emptied, shall be installed at the bottom of the heater or tank.

501.6 Water Heating Equipment

A shutoff valve shall be provided in the cold water branch line to each water storage tank or each water heater, on the same floor within 3 feet of the heater. Full port ball valve shut-offs on cold water branch lines to 2 inches or full port ball or resilient wedge-type shut-off valves for 2 1/2 inch lines and larger shall be used.

501.7 Location

501.7.1 Water heaters and storage tanks shall be so located and connected that they will be accessible for observation, maintenance, servicing and replacement.

501.7.2 Gas water heaters in residential garages shall be installed so that all burners and burner ignition devices are located not less than 18 inches above the floor.

501.7.3 Gas water heaters shall be located, or reasonably protected, so that they are not subject to physical damage by a moving vehicle.

501.7.4 Every attic or furred space in which water heaters and/or storage tanks are installed shall be readily accessible by an opening and passageway as large as the largest piece of equipment and in no case less than 22 x 36 inches (559 x 914 mm) continuous from the opening to the equipment and its controls. The opening to the passageway should be located not more than 20 ft (6096 mm) from the equipment measured along the center line of such passageway. Every passageway shall be unobstructed and shall have solid continuous flooring not less than 24 inches (610 mm) wide from the entrance opening to the equipment. On the control side and on other sides where

access is necessary for servicing of equipment, a level working platform extending a minimum 30 inches (762 mm) from the edge of the equipment with a 36 inch (914 mm) high clear working space shall be provided.

501.8 Marking

501.8.1 Water Heaters. All water heaters shall bear the following, or equal wording on a visible decal or label by the manufacturer:

There shall be installed at time of heater installation a combination temperature and pressure relief valve, selected and located in conformance with the requirements of ANSI Z21.22.

501.8.2 Pressure Marking of Storage Tanks. Any storage tank installed for domestic hot water shall have clearly and indelibly stamped in the metal, or so marked upon a plate welded thereto or otherwise permanently attached, the maximum allowable working pressure. Such markings shall be in an accessible position outside of the tank so as to make inspection or reinspection readily possible. All unlisted storage tanks for domestic hot water shall meet the applicable ASME standards.

502 DEFINITIONS

The following definition has been moved to Chapter 2:
WATER HEATER.

503 STANDARDS

503.1 Electric Water Heaters

Electric residential water heaters shall comply with FS A-A-2956 and UL 174.

503.2 Gas Water Heaters

Automatic storage type gas water heaters with inputs of 75,000 Btuh (22 kW), or less shall comply with ANSI Z21.10.1. Circulating tank, instantaneous and large automatic storage type gas water heaters shall comply with ANSI Z21.10.3.

503.3 Testing and Listing

Water heaters shall be tested and listed by an approved agency.

504 MINIMUM CAPACITIES FOR RESIDENTIAL WATER HEATERS

Water heaters installed in residential occupancies may be sized in accordance with Table 504.

Table 504
Minimum Capacities For Water Heaters^{1, 2, 3}

Number of Bathrooms	1 to 1.5			2 to 2.5				3 to 3.5			
	1	2	3	2	3	4	5	3	4	5	6
1st Hr Rating Gal.	42	54	54	54	67	67	80	67	80	80	80
Nom. Tank Size. Gal. Gas Water Heaters	20	30	30	30	40	40	50	40	50	50	50
Elect. Water Heaters	30	50	50	50	66	66	80	66	80	80	80
Oil Water Heaters	30	30	30	30	30	30	30	30	30	30	30

1 gal = 3.7854 L

Note:

1. The main criteria for a properly sized water heater is a sufficient first hour rating to meet peak hot water demand. The majority of tank sizes shown in the table will have a first hour rating equal to or greater than the first hour rating indicated. A water heater with a smaller tank size than shown in the table but with a sufficient first hour rating shall be permitted.
2. The first hour rating is found on the "Energy Guide" label.
3. Non-storage and solar water heaters shall be sized with sufficient capacity to meet the appropriate first hour rating shown in the table.

505 PROHIBITED INSTALLATIONS

505.1 Water heaters (using solid, liquid or gas fuel) with the exception of those having direct vent systems, shall not be installed in bathrooms and bedrooms or in a closet with access only through a bedroom or bathroom. However, water heaters of the automatic storage type may be installed as replacement in a bathroom, when specifically authorized by the plumbing official, provided they are properly vented and supplied with adequate combustion air.

Exception: When a closet, having a weather-stripped solid door with an approved door closing device, has been designed exclusively for the water heater and where all air for combustion and ventilation is supplied from outdoors.

505.2 Water heaters (using solid, liquid or gas fuel) shall not be installed in a room containing air handling machinery when such room is used as a plenum.

506 CONNECTIONS

506.1 The cold water branch line from the main water supply line to each hot water storage tank or water heater shall be provided with a valve accessible on the same floor, located near the equipment and only serving the hot water storage tank or water heater. The valving shall not interfere or cause a disruption of the cold water supply to the remainder of the cold water system.

506.2 The method of connecting a circulating water heater to the tank shall assure proper circulation of water through the heater, and permit a safe and useful temperature of water to be drawn from the tank. The pipe or tubes required for the installation of appliances which will draw from the water heater or storage tank shall be subject to the applicable provisions of this code for material and installation.

507 SAFETY DEVICES

507.1 Anti-Siphon Devices

507.1.1 Means acceptable to the plumbing official shall be provided to prevent siphoning of any water heater or tank to which any water heater or tank is connected. A cold water "dip" tube with a hole at the top or a vacuum relief valve installed in the cold water supply line above the top of the heater or tank may be accepted for this purpose.

507.1.2 Bottom fed heaters or bottom fed tanks connected to water heaters shall have a vacuum relief valve installed. The vacuum relief valve shall be in compliance with the appropriate requirements of ANSI Z21.22.

507.2 Water Temperature Control in Piping from Tankless Heaters.

The temperature of water from tankless heaters shall be tempered to 140°F (60°C) when intended for domestic uses. This provision shall not supercede the requirement for protective valves in the shower per 613.1.

507.3 Relief Valve

All storage water heaters operating above atmospheric pressure shall be provided with an approved, self-closing (levered) pressure relief valve and temperature relief valve or combination thereof, except for nonstorage instantaneous heaters. Such valves shall be installed in the shell of the water heater tank or may be installed in the hot water outlet, provided the thermo-bulb extends into the shell of the tank. Temperature relief valves shall be so located in the tank as to be actuated by the water in the top one-eighth of the tank served. For installations with separate storage tanks, said valves shall be installed on the tank and there shall not be any type of valve installed between the water heater and the storage tank. There shall not be a check valve or shutoff valve between a relief valve and the heater or tank which it serves. The relief valve shall not be used as a means of controlling thermal expansion. (see 613.2)

507.4 Energy Cutoff Device

All automatically controlled water heaters shall be equipped with an energy cutoff device which will cut off the supply of heat energy to the water tank before the temperature of the water in the tank exceeds 210°F (99°C). This cutoff device is in addition to the temperature and pressure relief valves.

507.5 Relief Valve Approval

Temperature and pressure relief valves, or combinations thereof, or energy shutoff devices shall bear the label of the AGA or ASME, with a thermostetting of not more than 210°F (99°C) and pressure setting not to exceed the tank or heater manufacturer's rated working pressure. The relieving capacity of these two devices shall each equal or exceed the heat input to the water heater or storage tank.

507.6 Relief Outlet Waste

The outlet of a pressure, temperature, or other relief valve shall not be directly connected to the drainage system.

507.7 Heater Over 200,000 Btuh Input

The relief valve shall have a minimum AGA temperature steam rating of 200,000 Btu (211,000 kJ), shall comply with all construction, testing and installation requirements of ANSI Z21.22, and shall have minimum 1 inch inlet and outlet pipe size connections. In addition, the temperature relieving element of the valve shall have a water discharge capacity based on 1250 Btu (1319 kJ) for each gallon per hour of water discharged at 30 psi (207 kPa) working pressure and a maximum temperature of 210°F (99°C). This rating must be certified by the valve manufacturer. Also, the pressure relieving element of the valve shall be ASME pressure steam rated. Both the temperature water rating and the ASME pressure steam rating of the combination temperature and pressure relief valve shall be equal to or in excess of the input to the hot water storage tank or storage water heater.

507.8 Safety Pans and Relief Valve Waste

507.8.1 When water heaters or hot water storage tanks are installed in remote locations such as suspended ceiling spaces or in attics, the tank or heater shall rest in a galvanized steel or other metal pan of equal corrosive

resistance having a thickness at least equal to 0.0276-inch (0.7 mm) galvanized sheet steel.

Exception: Electric water heaters may rest in a high impact plastic pan of at least 1/16 inch (1.6 mm) thickness.

507.8.2 Safety pans shall be no less than 1 1/2 inches (38mm) deep and shall be of sufficient size and shape to receive all drippings or condensate from the tank or heater. The pan shall be drained by a pipe no less than 1 inch (25.4 mm) diameter.

507.8.3 The pan drain shall extend full-size and terminate over a suitably located indirect waste receptor or floor drain or extend to the exterior of the building and terminate no less than 6 inches (152 mm) or more than 24 inches (610 mm) above grade.

507.8.4 The discharge from the relief valve shall be piped full-size separately to the outside of the building or to an indirect waste receptor so that any discharge can cause no personal injury or property damage and can be readily observed by the building occupants. Relief valve discharge piping shall contain no valves or traps and shall be so graded and connected as to drip to the discharge end of the piping by gravity. When the relief valve discharge is piped to the outside of the building, it shall terminate no less than 6 inches (152 mm) and no more than 24 inches (610 mm) above finish grade.

507.8.5 Relief valve discharge piping shall be of those materials listed in 611 or Table 507, or shall be tested and rated for such use.

Table 507
Relief Valve Materials

Material(s)	Standards
Water Heater Relief Valve Drain Tubes	ASME A 112.4.1

CHAPTER 6 WATER SUPPLY AND DISTRIBUTION

601 GENERAL

601.1 Scope

The provisions of this chapter shall govern the materials, design, construction, and installation of water supply and distribution systems.

★

601.8 Disinfection of Potable Water System

The plumbing official may require that a potable water system or any part thereof installed or repaired be disinfected in accordance with one of the following methods before it is placed in operation:

1. The system, or part thereof, shall be filled with a solution containing 50 ppm of available chlorine and allowed to stand 6 hours before flushing and returning to service.
2. The system, or part thereof, shall be filled with a solution containing 100 ppm of available chlorine and allowed to stand 2 hours before flushing and returning to service.
3. In the case of a potable water storage tank where it is not possible to as provided in (1.) or (2.), the entire interior of the tank shall be swabbed with a solution containing 200 ppm of available chlorine and the solution allowed to stand 2 hours before flushing and returning to service.
4. In the case of potable water filters or similar devices, the dosage shall be determined by the plumbing official.

601.9 Allowance for Character of Water

601.9.1 Selection of Materials. When selecting the material and size for water supply pipe, tubing, or fittings, due consideration shall be given to the action of the water on the interior and of the soil, fill or other material on the exterior of the pipe. No material that would produce toxic conditions in a potable water supply system shall be used for piping, tubing or fittings.

601.9.2 Used Piping. A piping material that has been used for other than a potable water supply system shall not be reused in the potable water supply system.

601.10 Hot Water Distribution

The hot water supply to any fixture requiring hot water shall be installed on the left side of the fixture unless otherwise specified by the manufacturer.

601.11 Tests

The water supply and distribution system shall be tested in accordance with 311.3.

601.12 Water Supply Mandatory

Every building used for human occupancy or habitation in which plumbing fixtures are installed shall be provided with an ample supply of potable water.

602 DEFINITIONS

The following definitions have been moved to Chapter 2: AIR GAP (WATER DISTRIBUTION), CRITICAL LEVEL, CROSS CONNECTION, EFFECTIVE OPENING, NON POTABLE WATER, WATER SUPPLY SYSTEM.

603 MATERIALS

Water service pipe and fittings shall be of materials specified in 608. Water distribution pipe, tubing and fittings shall be of materials specified in 611. Materials shall comply with the standards listed in Table 603.

Table 603
Water Pipe and Fitting Materials

MATERIALS	STANDARDS
PLASTIC WATER PIPE & FITTINGS	
ABS and PVC Plastic Tubular Fittings	ASTM F 409, ANSI/NSF 24, ANSI/NSF 14
Joints for IPS PVC Pipe Using Solvent Cement	ASTM D 2672
Chlorinated poly(vinyl chloride) (CPVC) plastic pipe, Schedule 80, 2" and under	ASTM F 441, Listed
Chlorinated Poly (Vinyl Chloride) (CPVC) Plastic Pipe (SDR-PR)	ASTM F 442
CPVC Pipe & Fittings	ASTM D 2846, Listed
Cross-linked Polyethylene/Aluminum/ Cross-linked Polyethylene (PEX-AL-PEX) pressure pipe and fittings	ASTM F 1281
Cross-linked Polyethylene (PEX) Plastic Hot-and Cold-Water Distribution System	ASTM F 877, Listed
Cross-linked Polyethylene (PEX) Tubing	ASTM F 876
Cross-linked Polyethylene (PEX) Tubing Systems for Pressure	CAN/CSA-B137.5-M89, Listed
Flexible Elastomeric Pressure Joints	ASTM D 3139, See 308.8
Metal Insert Fittings for PB Tubing	ASTM F 1380
Polyethylene/Aluminum/Polyethylene (PE-AL-PE) pressure pipe and fittings	ASTM F 1282
Polyethylene Pipe & Tubing (PE) Number 2305, 2306, 3306, 3406, 3408	ASTM D 2104, ASTM D 2239, ASTM D 2737, Listed, See 303.8.2
Poly (vinyl chloride) (PVC) plastic pipe fittings, schedule 40	ASTM D 2466
Pressure Rated ABS-Fittings	ASTM D 2468, Listed
Pressure Rated ABS-Pipe Number 1210, 2112, 1316	ASTM D 1527, ASTM D 2282, Listed, See 303.8.2
PVC Injection Molded Gasketed Fittings for Pressure Applications	CAN/CSA-B137.2-M89, Listed
PVC Pipe, Number 1120, 1220	ASTM D 1785, ASTM D 2241, Listed, See 303.8.2
PVC Socket-Type Fittings, Schedule 80	ASTM D 2467, Listed
Socket-type chlorinated poly(vinyl chloride) (CPVC) plastic pipe fittings, Schedule 80, 2" and under	ASTM F 439, Listed
Threaded chlorinated poly(vinyl chloride) (CPVC) plastic pipe fittings, Schedule 80, 2" and under	ASTM F 437, Listed
FERROUS WATER PIPE & FITTINGS	
Cast Iron Fittings (Threaded)	ASTM A 126
Cast Iron Pipe (Threaded)	ANSI A40.5
Cast Iron Water Pipe	ASTM A 377
Ductile-iron water pipe	ANSI/AWWA C151/A 21.51
Ductile-iron water fittings	ANSI/AWWA C110/A 21.10
Malleable Iron Fittings (Threaded)	ASTM A 197
Nipples Pipe (Threaded)	FS WW-N-351a
Stainless Steel Water Pipe Grade H	ASTM A 268, See 303.8.4
Steel couplings, threaded, black and galvanized	ASTM A 865
Steel Pipe Black and Galvanized	ASTM A 53
Welded and Seamless Steel Pipe	ASTM A 53

(continued)

Table 603 (continued)
Water Pipe and Fitting Materials

MATERIALS	STANDARDS
NONFERROUS PIPE & FITTINGS	
Cast Bronze Fittings for Flared Copper Tube	ANSI B16.26
Cast Bronze Threaded Fittings	ASME B16.15
Cast Bronze Solder-Joint Pressure Fittings	ANSI B16.18
Cast Copper Alloy Fittings for Flared Copper Tubes	ASME B16.26
Pipe Flanges & Flanged Fittings	ANSI B16.5
Seamless Brass Tube	ASTM B 135
Seamless Copper Pipe	ASTM B 42
Seamless Copper Tube	ASTM B 75
Seamless Copper Water Tube Types K, L & M	ASTM B 88
Seamless Red Brass Pipe	ASTM B 43
Seamless and Welded Copper Distribution Tube (Type D)	ASTM B 641
Threadless Copper Pipe (TP)	ASTM B 302
Welded Brass Tube	ASTM B 587
Welded Copper Tube	ASTM B 447
Welded Copper Alloy UNS No C 21000 Water Tube	ASTM B 642
Wrought-Copper and Copper Alloy Solder-Joint Pressure Fittings	ASME B16.22, For Copper Water Tube
Wrought Seamless Copper and rectangularCopper-Alloy Pipe and Tube	ASTM B 251, Square and tubing not applicable
Valves-Flanged Threaded, and Welding End	ANSI B16.34

604 QUALITY OF WATER SUPPLY

604.1 Potable Water

Potable water shall be used for drinking, culinary, and domestic purposes.

604.2 Acceptable Sources

Where a public supply of potable water is not available, requirements satisfactory to the governing authority shall be observed.

604.3 Nonpotable Water

Nonpotable water shall not be supplied to any fixture customarily classified a plumbing fixture and may only be used to supply industrial equipment or other appliances which do not require a potable supply of water and provided such nonpotable water shall not be accessible for drinking, culinary or bathing purposes.

605 COLOR CODE IDENTIFICATION

605.1 Color Coding

Piping and outlets conveying nonpotable water shall be adequately and durably identified by a distinctive yellow-colored paint so that it is readily distinguished from piping carrying potable water. See ASME A 13.1.

605.2 Nonpotable Water

Where nonpotable water is used, all valves, branch fittings and branch terminals shall be identified by the words "nonpotable water." This identification shall be done in accordance with ASME A 13.1. Such identification shall not be concealed by pipe insulation and when insulated the

insulation shall be painted the same color as is required for the pipe. Maintenance of all identification shall be the responsibility of the owner.

606 PROTECTION OF POTABLE WATER SUPPLY

606.1 Backflow and Back-Siphonage

606.1.1 Backflow. The water distribution system shall be protected against backflow. Every water outlet shall be protected from backflow, preferably by having the outlet end from which the water flows spaced a distance above the flood level rim of the receptacle into which the water flows sufficient to provide a "minimum required air gap" as defined in ASME A 112.1.2. Where it is not possible to provide a minimum air gap, the water outlet shall be equipped with an accessible backflow preventer complying with 606.2.

606.1.2 Back-Siphonage. Potable water supply piping, water discharge outlets, backflow prevention devices or similar equipment shall not be so located as to make possible their submergence in any contaminated or polluted liquid or substance.

606.2 Approval of Devices

Devices for the prevention of backflow or back-siphoning shall comply with the standards listed in Table 606. Devices installed in a potable water supply for protection against backflow shall be maintained in good working condition by the person or persons having control of such devices. The plumbing official may inspect such devices and, if they are found to be defective or inoperative, shall require the replacement thereof.

Table 606
Backflow Prevention Devices

MATERIALS	STANDARDS
Air Gap Standards	ASME A112.1.2
Backflow Preventers, Double Check Valve Assembly	ASSE 1015, ANSI/AWWA C510
Backflow Preventers with Intermediate Atmospheric Vent	ANSI/ASSE 1012
Backflow Preventers, Double Check Detector Assembly	ANSI/ASSE 1048
Backflow Preventers, Hose Connection	ANSI/ASSE 1052
Backflow Preventers, Reduced Pressure Detector Assembly	ANSI/ASSE 1047
Backflow Preventers, Reduced Pressure Principle Assembly	ASSE 1013, ANSI/AWWA C511
Dual Check Valve Type Backflow Preventer	ASSE 1032, For carbonated beverage dispensers- post mix type
Field Test Procedures for Backflow Preventer Assemblies	ASSE 5010
Manual for the Selection, Installation, Maintenance and Field Testing of Backflow Prevention Devices	CAN/CSA-B64.10
Vacuum Breakers, Anti-Siphon, Pressure Type Assembly (Outdoor Use)	ASSE 1020
Vacuum Breakers-Atmospheric Pipe Applied	ANSI/ASSE 1001
Vacuum Breakers, Back Siphonage, Pressure Type Assembly (Spill Resistant)	ANSI/ASSE 1056
Vacuum Breakers, Hose Connection	ANSI/ASSE 1011
Vacuum Breakers, Laboratory Faucet	ANSI/ASSE 1035
Vacuum Breaker Wall Hydrants, Frost Resistant Automatic Draining	ASSE 1019
Water Closet Flush Tank Fill Valves (Ballcocks)	ASSE 1002

606.3 Where Required

606.3.1 Flushometer. Flushometer valves shall be equipped with an approved vacuum breaker. The vacuum breaker shall be installed on the discharge side of the flushing valve with the critical level at least 4 inches (102 mm) above the overflow rim of the bowl. Flushometer tanks shall be provided with an approved backflow prevention device installed above the flood level rim of the fixture.

606.3.2 Flush Tanks. Flush tanks shall be equipped with an approved ballcock. The ballcock shall be installed with the critical level of the vacuum breaker at least 1 inch (25.4 mm) above the full opening of the overflow pipe. In cases where the ballcock has no hush tube, the bottom of the water supply inlet shall be installed at least 1 inch (25.4 mm) above the full opening of the overflow pipe. A sheathed ballcock shall be installed on all gravity flush tanks in which the flush valve seat is less than one inch (25.4 mm) above the flood level rim of the bowl.

606.3.3 Lawn Sprinklers and Irrigation Piping System. Lawn sprinkler systems and irrigation piping systems shall be equipped with an approved backflow preventer to protect against contamination of the potable water system. The following devices shall be acceptable:

1. Anti-siphon vacuum breakers, reduced pressure zone backflow preventer and pressure type vacuum breakers equipped with gate or ball valves and test cocks. (See Appendix D of the Louisiana State Plumbing Code for acceptable types based upon the application.)
2. Atmospheric type vacuum breakers shall be installed downstream of the last control valve at least 6 inches (152 mm) above the level of the highest sprinkler head.
3. All protective devices shall be installed in an accessible location to allow for inspection and maintenance and to isolate the sprinkler system from all other piping in the system.
4. Pressure type vacuum breakers shall be installed at least 12 inches (305 mm) above the level of the highest sprinkler head.

606.3.4 Fixture Valve Outlets with Hose Attachments, Hose Bibbs and Lawn Hydrants.

606.3.4.1 Fixture valve outlets with hose attachments, hose bibbs and lawn hydrants shall be protected against backflow by an air gap, a vacuum breaker or other approved back-siphonage backflow preventer on the discharge side of the valve. Back-siphonage backflow preventers may be installed directly on hose outlet connection threads. Vacuum breakers shall be installed at least 6 inches (152 mm) above the highest point of usage.

EXCEPTION: Water heater drains, boiler drains and washing machine connections shall not be required to be fitted with backflow prevention devices.

606.3.4.2 In areas subject to temperatures of 32°F (0°C) or below, all hose bibb vacuum breakers shall be of such design that the hydrant may be drained without removing the backflow preventer from the hydrant. Regardless of area temperature, hose bibb vacuum breakers shall be designed and installed to prevent total removal from the hose bibb after installation in accordance with the provisions of this code and the manufacturer's instructions.

606.3.5 Water Supply to Steam and Hot Water Heating Boilers, Heat Exchangers, Chilled Water Systems, Etc.
A backflow preventer device which will automatically vent to the atmosphere shall be installed in the water supply line to all steam and hot water space heating boilers, heat exchangers, chilled water systems and similar devices being supplied from the potable water system. Such devices shall prevent back-siphonage and backflow from the heating system into the potable supply lines should the supply pressure fall below the pressure in the heating system. Such devices shall meet the requirements of ASSE 1012 or 1013 and shall bear such identification as is required by the applicable standard. (See Appendix D of the Louisiana State Plumbing Code for acceptable types based upon the application.)

606.3.6 Connections to automatic fire sprinkler systems shall be required to meet the minimum requirements as referenced in Appendix D of the Louisiana State Plumbing Code.

606.3.7 Pull-out Spout Type Faucets

Pull-out spout type faucets shall be in compliance with CAN/CSA B125 or IAPMO PS 49 and have an integral vacuum breaker or vent to atmosphere in their design or shall require a dedicated deck or wall mounted vacuum breaker.

606.3.8 Portable Cleaning Equipment

Where the portable cleaning equipment connects to the water distribution system, the water supply system shall be protected against backflow with an air gap, an atmospheric type vacuum breaker, a pressure type vacuum breaker or a reduced pressure principle backflow preventer. (See Appendix D of the Louisiana State Plumbing Code for acceptable types based upon the application.)

606.3.9 Chemical Dispensers

Where chemical dispensers connect to the water distribution system, the water supply system shall be protected against backflow with an air gap, an atmospheric type vacuum breaker, a pressure type vacuum breaker or a reduced pressure principle backflow preventer. (See Appendix D of the Louisiana State Plumbing Code for acceptable types based upon the application.)

606.3.10 Dental Pump Equipment

Where dental pumping equipment connects to the water distribution system, the water supply system shall be protected against backflow with an air gap, an atmospheric

type vacuum breaker, a pressure type vacuum breaker or a reduced pressure principle backflow preventer. (See Appendix D of the Louisiana State Plumbing Code for acceptable types based upon the application.)

606.4 Backflow Preventer Installation

606.4.1 Reduced pressure zone (RPZ) type backflow preventers, and other types of backflow preventers with atmospheric ports and/or test cocks, shall not be installed below grade (in vaults or pits) where the potential for a relief valve, an atmospheric port, or a test cock being submerged exists.

606.4.2 Pipe applied atmospheric type vacuum breakers shall be installed not less than 6 inches above the flood level rim of the fixture receptor or device served. Pipe applied pressure type vacuum breakers shall be installed not less than 12 inches above the flood level rim of the fixture receptor or device served. Approved deck mounted vacuum breakers and vacuum breakers within equipment, machinery and fixtures, whether of the atmospheric or spill-proof pressure type, where the critical level is a fixed distance above the potential source of contamination, shall be installed not less than 1 inch (25.4 mm) above the flood level rim of the fixture receptor device served or source of contamination.

606.5 Shut-off Valves and Test Cocks Required

All pressure type backflow preventers which are designed for periodic field testing after installation in the pipeline shall be equipped with shut-off valves on both the inlet and the outlet side of the backflow preventer. In addition, test cocks shall be provided and so located that test equipment, gauges, etc., may be connected to the device at such points that the pressure in each pressure zone may be detected and, in addition, a test cock shall be located upstream of the upstream shut-off valve or installed in a special tapping on the upstream side of the upstream shut-off valve. But, in any case, such test cock shall be accessibly located as close to the device as practical. Where applicable approved standards specify otherwise, the location of test cocks shall be as specified by the standard. Full port ball valve shut-offs on backflow prevention sizes to 2 inches or full port ball or resilient wedge-type shut-off valves for 2 1/2 inches and larger shall be used.

606.6 Reduced Pressure Zone Backflow Preventers

Reduced pressure zone backflow applications subject to periodic no flow conditions should include a single soft seated spring loaded check valve located immediately upstream of the backflow prevention device to prevent periodic relief valve activation caused by fluctuating supply pressures.

606.7 Additional Requirements to Protect the Potable Water Supply

See Appendix D, Cross Connection Control, of the Louisiana State Plumbing Code for additional requirements. For other rules and regulations regarding potable water supply protection, see Chapter XII (Water Supplies) of the State Sanitary Code of Louisiana.

607 SIZING OF WATER DISTRIBUTION SYSTEM

607.1 Minimum Sizes

The sizing of the water distribution system shall conform to good engineering practice (e.g., see Appendix F). See 607.3 for minimum size of fixture supply line and 607.4 for minimum pressure at the fixture outlet.

607.2 Calculation of Sizes

When required by the plumbing official, the sizing of the water distribution system shall be calculated by a registered mechanical engineer or other acceptable authority.

607.3 Size of Fixture Supplies and Manifold Individual Distribution Lines

607.3.1 The minimum size of fixture supply pipe or manifold individual distribution lines shall be in accordance with Table 607.

Table 607
Minimum Size of Fixture Supply or Distribution Line

Type of Fixture or Device	Fixture Supply Pipe Size (in.)	Manifold Individual Distribution Line Size (in.)
Bathubs (60" x 32" and smaller)	1/2	1/2
Bathubs (Larger than 60" x 32")	1/2	1/2
Combination Sink and Tray	1/2	1/2
Drinking Fountain	3/8	1/2
Dishwasher (Domestic)	1/2	1/2
Kitchen Sink, Residential	1/2	1/2
Kitchen Sink, Commercial	3/4	3/4
Lavatory	3/8	1/2
Laundry Tray 1, 2, or 3 Compartments	1/2	1/2 (1 Tray)
Wall Hydrants	1/2	1/2
Shower (Single Head)	1/2	1/2
Sinks (Service, Slop)	1/2	1/2
Sinks Flushing Rim	3/4	3/4
Urinal (Flush Tank)	1/2	1/2
Urinal (Direct Flush Valve)	3/4	3/4
Water Closet (Flushometer Valve Type)	1	1
Water Closet (Gravity or Flushometer Tank Type)	3/8	1/2
Hose Bibbs	1/2	1/2

1 in. = 25.4 mm

607.3.2 For fixtures not listed, the minimum supply branch may be made the same as for a comparable fixture.

607.4 Minimum Pressure

Minimum fairly constant service pressure at the point of outlet discharge shall be not less than 8 psi (55.2 kPa) flowing for all fixtures except for direct flush valves, for which it shall be not less than 15 psi (103 kPa) flowing, and except where special equipment is used requiring higher pressure. In determining the minimum pressure, allowance Louisiana State Plumbing Code, 2000 edition®

shall be made for the pressure drop due to friction loss in the piping system during maximum demand periods as well as head, meter, and other losses in the system.

607.5 Auxiliary Pressure, Supplementary Tanks

If the residual pressure in the system is below the minimum allowable at the highest water outlet when the flow in the system is at peak demand, an automatically controlled pressure tank or automatically controlled pump or gravity tank of sufficient capacity shall be installed. Its capacity shall be sufficient to supply sections of the building installation which are too high to be supplied directly from the public water main.

607.6 Low Pressure Cutoff

When a booster pump is used on an auxiliary pressure system, there shall be installed a low-pressure (< 15 psi gauge) cutoff on the booster pump to prevent the creation of negative pressures on the suction side of the water system. Other arrangements may be used if found adequate and if approved by the plumbing official.

607.7 Variable Street Pressures

When the street main has a wide fluctuation in pressure, the water distribution system shall be designed for minimum pressure available.

607.8 Hazard and Noise

607.8.1 Where water pressures are excessive or where required to eliminate water hammer or when deemed necessary by local authorities, approved engineered water hammer arresters or calculated air chambers shall be provided to safeguard the water distribution system against destructive water hammer hazard and noise.

607.8.2 Approved engineered mechanical water hammer arresters shall be sized and installed in accordance with PDI-WH201, ANSI/ASSE 1010 or ANSI A112.26.1M. Where line water pressure exceeds 65 psi (448 kPa) in a water distribution system, the next larger size approved water hammer arrester shall be used. When water pressure exceeds 80 psi (552 kPa), a water pressure reducing valve shall be installed in accordance with 607.9. Any approved engineered mechanical water hammer arrester shall have been tested by a recognized testing laboratory and certified to meet the requirements of the above standard.

607.8.3 Where calculated air chambers are installed, they shall be in an accessible place and each air chamber shall be provided with an accessible means for restoring the air in the event the chamber becomes waterlogged.

607.9 Water Pressure Reducing Valve or Regulators

607.9.1 Where water pressure within a building exceeds 80 psi (552 kPa) static, an approved water pressure regulator conforming to ANSI/ASSE 1003 with strainer shall be installed to reduce the pressure in the building water distribution piping to 80 psi (552 kPa) static or less, whichever is consistent with good engineering practice. Exceptions to this requirement are service lines to sill

cocks and outside hydrants, and main supply risers in tall buildings where pressure from the mains is reduced to 80 psi (552 kPa) or less at the fixture branches or at individual fixtures.

607.9.2 The delivery pressure variation shall not exceed 1 psi (6.895 kPa) for every 10 psi (69 kPa) pressure change in the inlet pressure. The reduced pressure fall-off from its no-flow setting shall not exceed 17 psi (117 kPa), and with a difference at this point of 50 psi (345 kPa) between the initial and this reduced flow pressure of 50 psi (345 kPa), the capacity shall be not less than that shown in Table 607.9.

Table 607.9
Minimum Capacity Based on Pipe Size

Nom. Pipe Size (in)	1/2	3/4	1	1 1/4	1 1/2	2
Average velocity through pipe (ft/s)	10.5	10.0	9.5	9.0	8.5	7.5
Flow (gpm)	9.95	16.65	25.0	42.0	54.8	77.5

1 in = 25.4 mm
1 ft/s = 0.3048 m/s
1 gpm = 0.0631 L/s

607.9.4 An integral bypass check valve shall be capable of opening to permit a reverse flow of water through the reducing valve to prevent a buildup of system pressure by thermal expansion of the water with an increase of reduced pressure not exceeding 2 psi (13.8 kPa) above the prevailing initial pressure.

607.9.5 The valve shall be designed to remain open to permit uninterrupted water flow in case of valve failure.

607.9.6 All regulators and strainers must be so constructed and installed as to permit repair or removal of parts without breaking a pipeline or removing the valve and strainer from the pipeline.

607.9.7 Approved valves shall comply with ANSI/ASSE 1003.

607.10 Manifold Water Distribution Systems

607.10.1 Hot water and cold water manifolds shall be sized according to Table 607.10.

Table 607.10
Maximum Gallons Per Minute (GPM) Available²

Nominal Size ID (Inches)	Velocity ¹	
	4 fps	8 fps
1/2	2	5
3/4	6	11
1	10	20
1 1/4	15	31
1 1/2	22	44

1 in = 25.4 mm
1 fps = 0.3048 m/s
1 gpm = 0.0631 L/s

Notes:

1. For velocity limitations use manufacturers' recommendations.
2. Total gpm is the demand of all outlets.

607.10.2 Individual distribution line size shall conform to Table 607 or to good engineering practice (e.g., see Appendix F).

607.10.3 Individual fixture shutoff valves shall be installed at the outlet for each fixture. If secondary shutoff valves are used at the manifold, they shall be identified for the fixture being supplied.

607.10.4 Piping bundles for manifold systems shall be supported in accordance with Chapter 3. Direction changes and bending radiuses shall be in accordance with manufacturer's recommendations.

608 WATER SERVICE PIPE AND FITTINGS

608.1.1 Materials Underground

Materials for underground water service pipe and lawn sprinkler systems, shall be a minimum Type L copper tube, brass, cast iron pressure pipe, ductile-iron, or pressure-rated plastic as listed in Table 603. Water pipe and fittings with more than 8.0% lead shall not be used. The minimum working pressure of plastic piping installed outside of the foundation walls shall be 160 psi (1103 kPa) at 73°F (23° C), with permanent identification markings.

608.1.2 Materials subject to corrosion shall be protected when installed in corrosive soils. Approved fittings shall be used on the water supply system, except that changes of direction in copper tube (ASTM B 88) may be made with bends having a radius of not less than four diameters of the tube, providing that such bends are made by use of forming equipment which does not deform or create loss in cross-sectional area of the tube. If allowed by the manufacturer, bends of pressure-rated plastic pipe listed in Table 603 shall be installed to conform with the manufacturer's recommendations but in no case shall the bend radius be less than the requirements contained within Sections 611.1.4 through 611.1.7, as applicable.

608.1.3 All pipes, pipe fittings, solder and flux used in the installation of water supply systems shall be lead free.

Exception: Leaded joints may be used for the repair of existing cast iron pipes.

608.2 Water Service Piping

Water service lines shall be sized in accordance with accepted engineering practice (e.g., see Appendix F), but in no case shall the water service piping be less than one inch inside nominal diameter for galvanized ferrous piping or 3/4 inch inside diameter for copper, copper alloy or approved noncorrosive pipe or tube.

608.3 Service Lines Near Drain or Sewer Line

Except as permitted in 608.4, the underground water service pipe and the building drain or building sewer shall be not less than 5 ft (1524 mm) apart horizontally and shall be separated by undisturbed or compacted earth.

608.4 Permitted Installation Near Drain or Sewer Line

The water service pipe may be placed in the same trench with the building drain and building sewer provided the following conditions are met:

1. The bottom of the water service pipe, at all points, shall be at least 12 inches (305 mm) above the top of the sewer line at its highest point.
2. The water service pipe shall be placed on a solid shelf excavated at one side of the common trench.
3. Any underground water service pipe which must cross a pipe that conveys sewage (e.g., building drains, building sewers, and other piping conveying sewage) shall have a minimum vertical separation of 12 inches (305 mm) between the outside of the water service pipe and the outside of the sewer pipe. The water service pipe should always be installed above the sewer pipe. At crossings, one full length of water pipe shall be located so both joints will be as far from the sewer pipe as possible.

608.5 Stop and Waste Valves and Devices

Combination stop and waste valves and cocks shall not be installed underground in a water supply system. Any fixture or device which incorporates a stop and waste feature is prohibited if the waste opening is underground or in any location that waste water or water-borne contaminants may enter the device or water supply from the ground or other source by reversal of flow.

608.6 Private Water Supply

No private supply shall be interconnected with any public water supply.

608.7 Potable Water (Pressure) Lines Near Soil Absorption Trenches, Sand Filter Beds and Oxidation Ponds

Underground potable water (pressure) lines shall not be located within 25 feet (7.6 m) of any soil absorption trenches, sand filter beds, or oxidation ponds which have been installed for the disposal of septic tank effluent.

608.8 Potable Water (Pressure) Lines Near Septic Tanks, Mechanical Sewage Treatment Plants, and Pump Stations

Underground potable water (pressure) lines shall not be located within 10 feet (3.0 m) of any septic tank, mechanical sewage treatment plant, or sewage pump station.

608.9 Potable Water (Pressure) Lines Near Seepage Pit, Cesspool, or Sanitary Pit Privy

Underground potable water (pressure) lines shall not be located within 50 feet (15.2m) of any seepage pit, cesspool, or sanitary pit privy.

609 WATER PUMPING AND STORAGE EQUIPMENT

609.1 Pumps and Other Appliances

Water pumps, tanks, filters, softeners, and all other appliances and devices shall be protected against contamination.

609.2 Drains from Pressure Tanks, Boilers, and Relief Valves

The drains from pressure tanks, boilers, relief valves and similar equipment shall not be directly connected to the drainage system.

609.3 Cleaning, Painting, Repairing Water Tanks

A potable water supply tank shall not be lined, painted, or repaired with any material which will affect either the taste or the potability of the water supply when the tank is returned to service. Tanks shall be disconnected from the system during such operations, to prevent any foreign fluid or substance from entering the distribution piping.

609.4 Insufficient Pressure

When the water pressure from the water main (or other approved sources of potable water supply) during flow is insufficient to supply all fixtures freely and continuously, the rate of supply shall be supplemented by a gravity house tank or booster system. (see 607.6)

609.5 Support

All water supply tanks shall be supported in accordance with the Standard Building Code or other regulations which apply.

609.6 Overflow Pipes

Overflow pipes for gravity tanks shall be protected against the entrance of insects and vermin and shall discharge above and within 6 inches (152 mm) of a roof or catch basin. Overflow pipes shall not be valved.

609.7 Drains

609.7.1 Water supply tanks shall be provided with the valved drain lines located at their lowest point and discharged as an indirect waste. Drains for water supply tanks shall be not less than shown in Table 609.7.

Table 609.7
Minimum Drain Size for Water Supply Tanks

Drain Pipe (in)	Tank Capacity (gal)	Drain Pipe (in)	Tank Capacity (gal)
1	Up to 750	2 1/2	3001 to 5000
1 1/2	751 to 1500	3	5001 to 7500
2	1501 to 3000	4	Over 7500

1 in = 25.4 mm

1 gal = 3.7854 L

609.7.2 Each drain line shall be equipped with a quick opening valve of the same diameter as the pipe.

609.8 Gravity and Suction Tank

Tanks used for potable water supply shall be equipped with tight covers which are vermin and rodent proof. Such tanks shall be vented with a return bend vent pipe having an area not less than one-half the area of the feed riser, and the vent opening shall be properly screened.

609.9 Pressure Tank

Pressure tanks used for supplying potable water shall be equipped with an approved vacuum relief device located on the top of the tank. The air inlet of this device shall be properly screened.

610 WATER SUPPLY CONTROL

610.1 Valves Required

An accessible shutoff valve shall be provided on the consumer's premises ahead of the first outlet or branch connection to the service or distribution pipe of each dwelling, dwelling unit and buildings other than dwellings and dwelling units. Full port ball valve shut-offs on lines to 2 inches or full port ball or resilient wedge-type shut-off valves for 2½ inch lines and larger shall be used. When such shutoff valve is located in the service pipe outside the building, it shall be located and accessible in a manufactured, approved, valve box with a readily removable access cover which extends to grade level. When drain valves are provided for the distribution piping or other portion of the water supply system, such drains shall be above grade or otherwise located to prevent the possibility of backflow into the piping system after the system has been drained.

610.2 Tank Controls

Supply lines taken from pressure or gravity tanks shall be valved at or near the tank.

610.3 Controls for Fixtures Within Dwellings and Dwelling Units

610.3.1 Each individual fixture shall have an accessible shutoff valve at each outlet which will permit each fixture to be shut off without interfering with the water supply to any other fixtures. Shutoff valves for each fixture supplied by a manifold distribution system may be located at the manifold in addition to the outlet of the fixture being supplied. The hose bibb or hose connection shutoff valve shall be the only shutoff valve required on washing machine connectors.

610.3.2 Shutoff valves to water supply for refrigerators with automatic ice makers shall be accessible on the same floor.

610.4 Buildings Other Than Dwellings or Dwelling Units

610.4.1 In all buildings other than dwellings and dwelling units, shutoff valves shall be installed which permit the water supply to all fixtures and equipment in each separate room to be shut off without interference with the water

supply to any other room or portion of the building or each individual fixture and piece of equipment shall have a shutoff valve which will permit each fixture and piece of equipment to be shut off without interfering with the water supply to other fixtures or equipment.

610.4.2 Each water supply branch line 1½ inch or larger shall have a shutoff valve installed so as to isolate all fixtures and all pieces of equipment supplied by the branch line. The shutoff valve shall be installed in a labeled and accessible location as close to the connection to the supply main and/or riser as practical.

611 WATER DISTRIBUTION PIPE, TUBING AND FITTINGS

611.1 General

611.1.1 Minimum working pressure for plastic hot and cold piping material shall be 100 psi (689.5 kPa) at 180°F (82°C).

611.1.2 All pipes, pipe fittings, solder and flux used in the installation of water distribution systems shall be lead free.

EXCEPTION: Leaded joints may be used for the repair of existing cast iron pipes.

611.1.3 All pipes, pipe fittings, solder and flux shall conform to the standards listed in Table 603.

611.1.4 Bends of cross-linked polyethylene (PEX) plastic tubing shall be installed to conform to the manufacturer's recommendations but in no case shall the bend radius be less than the following:

1. When bent with the coil-a bending radius equivalent to or greater than 8 times the outside diameter of the tubing shall be maintained. Outside diameter is equal to the inside nominal diameter plus 1/8 inch.
2. When bent against the coil-a bending radius equivalent to or greater than 24 times the outside diameter of the tubing shall be maintained. Outside diameter is equal to the inside nominal diameter plus 1/8 inch.

611.1.5 Because the linear expansion rate for cross-linked polyethylene (PEX) tubing is about 1 inch/10°F for each 100 feet (30 m) of tubing, it should not be rigidly anchored to any support in order to allow for freedom of movement during expansion and contraction. When installing long runs of tubing, a longitudinal clearance of 1/8 to 3/16 inch per foot of run should be allowed to accommodate for thermal expansion. PEX tubing, where it passes through concrete or a similar building material which would not allow for freedom of linear expansion, shall be provided with a pipe sleeve of schedule 40 pipe which shall be built into the foundation, footing, floor, wall or ceiling. Such pipe sleeve shall be of sufficient inside diameter to allow for the free expansion and contraction of the PEX tubing and to prevent any rubbing action.

612 JOINTS

611.1.6 The maximum recommended spacing between horizontal supports for cross-linked polyethylene (PEX) tubing is 32 inches (813 mm) for nominal tubing diameters from 1/4 inch through 2 inch. It should not be rigidly secured to a joist or stud but should be secured with smooth plastic strap hangers, which permit ease of movement during expansion or contraction. Valve and fixture connections to which PEX pipe is connected shall be rigidly anchored.

611.1.7 Bends of chlorinated polyvinyl chloride (CPVC) plastic pipe shall be installed to conform to the manufacturer's recommendations but in no case shall the bend radius be less than the following:

1. A bending radius equivalent to or greater than 18 inches (457 mm) for 1/2 and 3/4 inch inside nominal diameter piping.
2. A bending radius equivalent to or greater than 24 inches (610 mm) for 1 inch inside nominal diameter piping.

611.2 Materials Above Ground

Materials for water distribution pipes and tubing shall be brass, copper water tube minimum type L, stainless steel water tube minimum Grade H, cast iron pressure pipe, ductile-iron, galvanized steel, chlorinated polyvinyl chloride (CPVC) or cross-linked polyethylene (PEX) plastic pipe or tubing, all to be installed with approved fittings; except that changes in direction in copper tube (ASTM B 88) may be made with bends having a radius of not less than four diameters of the tube, providing that such bends are made by use of forming equipment which does not deform or create a loss in cross-sectional area of the tube. Translucent PEX plastic pipe or tubing, when installed above ground, shall not be exposed to direct or indirect sunlight.

611.3 Materials Below Ground

Inaccessible water distribution piping under slabs shall be copper water tube minimum type L, brass, cast iron pressure pipe, ductile-iron pipe, chlorinated polyvinyl chloride (CPVC) or cross-linked polyethylene (PEX) plastic pipe or tubing, all to be installed with approved fittings or bends. All copper tubing joints below a building slab shall be brazed. Joints for plastic pipe and fittings below a building slab are prohibited. Any material subject to corrosion shall be protected when used in corrosive soils.

611.4 Valves

Valves shall conform to the standards listed in Table 611.4

Table 611.4
Valve Standards

MATERIALS	STANDARDS
Valves, Bronze Gate	MSS SP-80
Valves, Cast Iron Gate	ASTM A 126
Valves, Ball	MSS SP-72, MSS SP-110
Valves, Resilient-Seated Gate	ANSI/AWWA C509

612.1 General

This section contains provisions applicable to joints specifically for water service and distribution piping. Provisions for those joining methods which are applicable to more than one piping system are contained in Chapter 3.

612.2 Soldered Joints

Soldered joints for tubing shall be made with approved fittings. Surfaces to be soldered shall be cleaned bright, all burrs shall be removed and the tubing shall be returned to full bore. The joints shall be properly fluxed and made with approved solder (See 303.7.1, item 4 and 612.6). All solder and flux used in the installation or repair of water supply or distribution systems shall be lead free. Soldered joints should not be made closer than 18 inches (457 mm) to an installed plastic-to-metal adapter in the same water line.

612.3 Flared Joints

Flared joints for soft tempered copper water tube shall be made with fittings meeting approved standards. The tubing shall be expanded with a proper flaring tool.

612.4 Brazed Joints

Brazed joints shall be made in accordance with the provisions of Section 6 of ANSI B31.1. Brazed joints should not be made closer than 18 inches (457 mm) to an installed plastic-to-metal adapter in the same water line.

612.5 Joints for Plastic Water Service and Water Distribution Pipe and Fittings

612.5.1 General. Plastic pipe and fittings for water service piping and water distribution piping may be of the insert type, compression type, solvent cemented, heat fused, pressure-lock, or may be hot or cold flared as recommended by the manufacturer or the Plastic Pipe Institute for the particular materials being used. (See Table 303 for approved primers and solvent cements. Also, see 308.8.1.)

612.5.2 Polyethylene Water Service. Stiffener inserts used with compression type fittings shall not extend beyond the clamp or nut of the fitting. For bends, the installed radius of pipe curvature shall be not less than 30 pipe diameters, or the coil radius when bending with the coil. Coiled pipe shall not be bent beyond straight. Bends shall not be permitted closer than 10 pipe diameters of any fitting or valve. Kinked pipe shall not be used. Pipe shall be cut square, using a cutter designed for plastic pipe. Except where joined by heat fusion, pipe ends shall be chamfered to remove sharp edges. Heat fusion joints shall be made in accordance with ASTM D 2657 or ASTM F 1290. Flared joints shall be permitted where recommended by the manufacturer and made by the use of a tool designed for that operation.

612.6 Copper Water Tube and Stainless Steel Water Tube

Joints for copper water tube or stainless steel water tube shall be formed either by the appropriate use of approved brass,

bronze or wrought copper water fittings, properly soldered or brazed together, or by means of approved flare fittings as provided in 612.3.

612.7 Special Joints

612.7.1 Copper Water Tubing or Stainless Steel Tubing to Threaded Pipe Joints. Joints from copper water tubing or stainless steel tubing to threaded pipe shall be formed by the use of bronze or copper adapter fittings. The joint between the copper tube or stainless steel tube and fittings shall be properly soldered or brazed, and the connection between the threaded pipe and the fitting shall be made with a standard pipe size threaded joint.

612.7.2 Ground Joint Brass Connections. Ground joint brass connections which allow adjustment of tubing but provide a rigid joint when made up shall not be considered as slip joints.

612.7.3 Plastic Pipe to Other Materials. Joints between plastic pipe and other materials shall be formed with proper adaption fittings as furnished by the manufacturer.

612.7.4 Unions. Unions in the water supply system shall be metal-to-metal with ground seats.

613 SAFETY DEVICES

613.1 Shower Temperature Control Devices

The temperature of mixed water to multiple (gang) showers shall be controlled by a master thermostatic valve conforming to ASSE 1017 or such showers shall be individually controlled by a scald preventative valve of the pressure balancing, thermostatic or combination mixing valve type conforming to ASSE 1016. The temperature of mixed water to individual showers and shower/bath combinations in all buildings shall be controlled by a scald preventative valve of the pressure balancing, or thermostatic or combination mixing valve type conforming to ASSE 1016. All scald preventative valves shall be equipped with a means to limit the maximum setting of the valve to 120°F (48.3° C). Handle position stops or any other limit setting devices shall be adjusted in accordance with manufacturer's instructions at time of installation to a maximum mixed water outlet temperature of 120°F (48.3° C).

**Table 613
Temperature Control Device Standards**

MATERIALS	STANDARDS
Individual Shower Control Valves, Anti-Scald	ASSE 1016
Temperature Actuated Mixing Valves for Primary Domestic Use	ASSE 1017
Water Supply Valves: Mixing Valves and Single Control Mixing Valves	ASSE 1029

613.2 Thermal Expansion Control

613.2.1 If water is heated and stored in a consumer's system and the system has been closed by the installation of a backflow preventer or a pressure reducing valve, a thermal expansion control shall be installed at an accessible location between the checking device and the water heating equipment to limit thermal expansion of the water being heated to not more than 80 pounds per square inch (552 kPa) static pressure at any fixture on the system. A potable water expansion tank or auxiliary relief valve set at 80 psi (552 kPa) shall be acceptable.

613.2.2 The auxiliary relief valve shall be in addition to the water heater safety relief valve. This thermal expansion control device shall be designed and trimmed for repeated operation. The valve shall be a minimum 1/2 inch pipe size, shall be adjustable and calibrated, and shall include a tag describing its function.

613.3 Non-Shower Mixing Valves

Non-shower and non-shower/bath combination plumbing fixture fittings utilizing mixing valves and single control mixing valves, as defined under the ASSE 1029 standard, shall meet the requirements of ASSE 1029.

614 MISCELLANEOUS

614.1 Drain Cock

All storage tanks shall be equipped with adequate drain cocks.

614.2 Line Valves

Valves in the water supply distribution system, except those immediately controlling one fixture supply, when fully opened shall have a cross-sectional area at the smallest orifice or opening through which the water flows at least equal to the cross-sectional area of the nominal size of the pipe in which the valve is installed.

614.3 Water Used for Processing

Water used for cooling of equipment or similar purposes shall not be returned to the potable water distribution system. When discharged to the building drainage system or other point of disposal, the waste water shall be discharged through an air gap.

614.4 Trap Primers

614.4.1 Trap primers which are connected directly to a potable water system shall conform to ASSE 1018. Trap primers which are connected directly to a potable water system shall be constructed with integral air gaps.

614.4.2 Trap primers shall be accessible and shall not be concealed by building or other construction.

614.4.3 Trap primer drains shall be constructed to completely drain by gravity after each cycle of operation and, in no case, shall the drain be connected to the trap below the top of the trap water seal or trap outlet weir.

614.4.4 Trap primer air gaps, when required, shall be located a minimum of 6 inches (152 mm) above the flood level of the floor drain or receptor served.

614.4.5 Trap primers shall be connected to the cold water supply in accordance with the manufacturer's recommendations.

EXCEPTION: Source water may be a fixture drain for trap primers constructed in accord with Figure 14 of Appendix J.

614.4.6 Separate cutoff valves shall not be installed between a trap primer and its water supply except that a cutoff valve for an individual fixture shall control both the water supply to the trap primer and the individual fixture to assure a constant supply to the primer.

615 WATER TREATMENT UNITS

615.1 Drinking water treatment units shall meet the requirements of ANSI/NSF 42 and 53. Units are designed to be used for the reduction of specific contaminants from potable drinking water, such contaminants being considered as potential health hazards or affecting the aesthetic quality characteristics of potable drinking water.

615.2 Reverse osmosis drinking water treatment systems shall meet the requirements of ANSI/NSF 58. Systems are designed to be used for the reduction of specific contaminants from potable drinking water supplies considered to be microbiologically safe and of known quality (except that claims for the reduction of filterable cysts may be permitted). Systems covered by this standard are intended for reduction of total dissolved solids (TDS) and other contaminants specified therein.

615.3 Waste and discharge from reverse osmosis or other types of water treatment units shall enter the drainage system through an air gap.

616 SOLAR ENERGY UTILIZATION

Solar energy systems used for heating potable water or using an independent medium for heating potable water shall comply with the applicable requirements of this code. The use of solar energy shall not compromise the requirements for cross connection or protection of the potable water supply system required by this code. Solar energy systems shall also meet the applicable requirements of the Standard Building Code, Standard Gas Code, Standard Mechanical Code and the locally adopted energy code.

617 APPENDIX REFERENCES

Additional provisions for water supply and distribution are found in the following appendices: Appendix B - Travel Trailers and Travel Trailer Parks; Appendix C - Mobile/Manufactured Homes and Mobile/Manufactured Home Parks; Appendix D - Cross-Connection Control; Appendix F -

Sizing of Water Piping System; and Appendix G - Medical Facilities Plumbing Systems. These provisions are applicable only when they are referenced in the body of the code sections or when included in the adopting ordinance.

CHAPTER 7 SANITARY DRAINAGE

701 GENERAL

701.1 Scope

The provisions of this chapter shall govern the materials, design, construction, and installation of sanitary drainage systems.

701.6 Frost Protection

No soil or waste pipe shall be installed or permitted outside of a building, or concealed in outside walls or in any place where they may be subjected to freezing temperatures, unless adequate provision is made to protect them from freezing.

701.7 Damage to Drainage System or Public Sewer

Wastes detrimental to the public sewer system or detrimental to the functioning of the sewage-treatment plant shall be treated and disposed of in accordance with section 1004 or an approved pretreatment system as directed by the plumbing official.

701.8 Individual or Private Sewage Disposal System

Where a public sewer is not available, an individual sewage disposal system shall be of a type that is acceptable and approved by the plumbing official or other governing authority having jurisdiction. See Appendix E.

701.9 Tests

The sanitary drainage system shall be tested in accordance with 311.

701.10 Engineered Systems

Engineered sanitary drainage and venting systems shall conform to the provisions of Chapter 12.

702 DEFINITIONS

The following definitions have been moved to Chapter 2:
HORIZONTAL PIPE, UNSTABLE GROUND, VERTICAL PIPE.

703 MATERIALS

703.1 General

Pipe, tubing, and fittings for drainage systems shall conform to the standards listed in Table 703.

703.2 Specific Type

Standards listed in Table 703 apply to the specific materials approved for use and, as indicated in the various sections in this chapter, as they apply to the drainage system.

703.3 Aboveground Piping Within Buildings and Piping in Raceways or Tunnels

703.3.1 Soil and waste piping for drainage systems shall be of cast iron, galvanized steel, brass or copper pipe, type DWV copper tube, Schedule 40 plastic piping or borosilicate glass.

703.3.2 Vertical soil, waste and vent stacks shall be designed to control expansion and contraction, in accordance with accepted engineering practice, to the satisfaction of the plumbing official.

703.4 Underground Piping Within Buildings

All underground drains within buildings shall be cast iron soil pipe, ductile-iron pipe, type DWV copper, heavy schedule borosilicate glass, or Schedule 40 plastic piping. Materials subject to corrosion shall be protected when installed in corrosive soils.

**Table 703
Drainage System Materials**

MATERIALS	STANDARDS
NONMETALLIC PIPING	
Clay Drain Pipe	ASTM C 4
Clay Pipe Flexible Joint	ASTM C 425
Clay Sewer Pipe	ASTM C 700, Markings shall include ASTM number
Concrete Drain Tile	ASTM C 412
Concrete Perforated	ASTM C 444
Concrete Reinforced Culverts	ASTM C 76, For storm drains only
Concrete Reinforced Sewer Pipe	ASTM C 361, For storm drains only
Concrete Sewer Pipe	ASTM C 14, For storm drains only
Sewer Manholes	ASTM C 478
Concrete (Steel Cylinder Type)	FS SS-P-381
PLASTIC PIPE AND FITTINGS	
ABS-DWV Pipe and Fittings	ASTM D 2661, Listed, See 303.8.3
ABS Sewer Pipe and Fittings (for outside building sewers, storm drains and storm sewers)	ASTM D 2751, See 704.1, 1101.5, 1103.2, and 1103.4, Installation: ASTM D 2321
Acrylonitrile-Butadiene-Styrene (ABS) Schedule 40 Plastic Drain Waste, and Vent Pipe with a Cellular Core	ASTM F 628, Listed
Coextruded Composite Pipe	ASTM F 1488, See 303.8.3, 303.8.5, 704.1, 1101.5, 1103.2, 1103.4.
Coextruded Composite Drain, Waste, and Vent Pipe (DWV)	ASTM F 1499, See 303.8.3, 303.8.5, 704.1, 1101.5, 1103.2, 1103.4.
Coextruded PVC Plastic Pipe	ASTM F 891, See 303.8.3, 303.8.5, 704.1, 1101.5, 1103.2, and 1103.4
Flexible Elastomeric Non-Pressure Joints	ASTM D 3212, See 303.8
Large Diameter Ribbed PVC Sewer Pipe and Fittings	CAN/CSA-B182.4
Polyolefin Laboratory Drainage Systems	CAN/CSA-B181.3
PVC-DWV Pipe and Fittings	ASTM D 2665, Listed, See 303.8.3
Type PS 46 and Type PS 115 Sewer Pipe (for outside building sewers, storm drains)	ASTM F 789, See 704.1, 1101.4, 1103.2 and 1103.4, ASTM D 2321, Installation
Type PSM PVC Sewer Pipe & Fittings (for outside building sewers, storm drains and storm sewers)	ASTM 3034, See 704.1, 1101.5, 1103.2, and 1103.4 ASTM D 2321, Installation
Type PSP PVC Sewer Pipe & Fittings (for outside building sewers, storm drains and storm sewers)	ASTM D 2321, Installation

(continued)

**TABLE 703 (continued)
DRAINAGE SYSTEM MATERIALS**

MATERIALS	STANDARDS
FERROUS PIPE AND FITTINGS	
Cast Iron Soil Pipe and Fittings	ASTM A 74, CISPI HS
CI NO-HUB Pipe and Fittings	CISPI Std. 301 ASTM A 888
Ductile-Iron Gravity Sewer Pipe	ASTM A 746
Hubless Cast Iron Sanitary System	CISPI Std. 310
Manhole Top Frames and Covers	ASTM A 48
NONFERROUS PIPE & FITTINGS	
Cast Copper Alloy Solder-Joint Drainage Fittings	ASME B 16.23, For Plumbing Drainage Waste and Vents
Cast Copper Alloy Solder Joint Fittings for Solvent Drainage Systems	ANSI B 16.32
Copper Drainage Tube DWV	ASTM B 306
Lead Pipe, Bends and Traps	FS WW-P-325
Welded Copper and Copper Alloy Heat Exchanger Tube	ASTM B 543
Wrought Copper and Wrought Copper Alloy Solder-Joint Drainage Fittings For Plumbing Drainage Waste and Vents	ASME B16.29
Wrought Copper and Copper Alloy Solder-Joint Fittings for Solvent Drainage Systems	ANSI B16.43
GLASS PIPE	
Borosilicate Glass Pipe and Fittings for DWV Applications	ASTM C 1053

703.5 Fittings

Fittings on the drainage system shall be compatible to the type of piping used. Fittings on threaded pipe shall be of the recessed drainage type. See 307.

703.6 Acid Soil and Waste Piping

Acid soil and waste piping for drainage systems shall be of a high silicon cast iron, borosilicate glass or other materials approved by the plumbing official. Fittings shall conform to the type of piping used. Acid soil and waste piping shall not be connected to the conventional plumbing system.

704 BUILDING SEWER

704.1 Separate Trenches

The building sewer, when installed in a separate trench from the water service pipe, shall be cast iron sewer pipe, vitrified clay sewer pipe, or plastic piping (minimum SDR 35 or heavier). Joints shall be watertight and rootproof and all material shall be installed according to the manufacturer's recommendations. (See Appendix I.) All pipe and fittings shall bear the manufacturer's name or trademark.

704.2 Sewer in Filled Ground

A building sewer or building drain installed in unstable fill or unstable ground shall be of cast iron pipe, except that nonmetallic drains may be laid upon an approved continuous supporting system if installed in accordance with 704.1.

704.3 Sanitary and Storm Sewers

Where separate systems of sanitary drainage and storm drainage are installed in the same property, the sanitary and storm building sewers or drains may be laid side by side in one trench.

704.4 Old House Sewers and Drains

Old building sewers and building drains may be used in connection with new building or new plumbing and drainage work only when they are found, on examination and test, to conform in all respects to the requirements governing new house sewers. The plumbing official shall notify the owner to make the changes necessary to conform to this code.

704.5 Cleanouts on Building Sewers

Cleanouts on building sewers shall be located as set forth in 710.2.

704.6 Minimum Size Building Sewer

No building sewer shall be less than 4 inches in size with the exception of force lines.

704.7 Backwater Valves

704.7.1 Fixture Branches

Backwater valves shall be installed in the branch of the building drain which receives only the discharge from fixtures located below grade. Where fixtures are located below the level of the top of the first upstream manhole, said fixtures shall be protected by a backwater valve.

704.7.2 Material

Backwater valves shall have all bearing parts of corrosion resistant material. Backwater valves shall comply with ASME A 112.14.1 or CAN/CSA B181.1, CAN/CSA B181.2.

704.7.3 Seal

Backwater valves shall be so constructed as to insure a mechanical seal against backflow.

704.7.4 Diameter

Backwater valves, when fully opened, shall have a capacity not less than that of the pipes in which they are installed.

704.7.5 Location

Backwater valves shall be so installed to be accessible for service and repair.

705 DRAINAGE PIPING INSTALLATION

705.1 Horizontal Drainage Piping

Horizontal drainage piping shall be installed at a uniform slope but at slopes not less than permitted in 705.2, 705.3 and 705.4.

705.2 Small Piping

Horizontal building drainage piping less than 3-inch diameter shall be installed with a fall of not less than 1/4 inch per ft (21 mm per meter).

705.3 Large Piping

Horizontal building drains 3-inch diameter or larger shall be installed with a fall of not less than 1/8 inch per ft (10 mm per meter).

705.4 Minimum Velocity

Where conditions do not permit building drains and sewers to be laid with a fall as great as that specified, then a lesser slope may be permitted provided the computed velocity will be not less than 2 fps (0.61 m/s).

706 JOINTS

706.1 General

This section contains provisions applicable to joints specific to sanitary drainage piping. Provisions for those joining methods which are applicable to more than one piping system are contained in Chapter 3.

706.2 Caulked Joints

Caulked joints for cast-iron hub-and-spigot soil pipe shall be firmly packed with oakum or hemp and filled with molten lead not less than 1 inch (25.4 mm) deep and extending not more than 1/8 inch (3.18 mm) below rim of hub. No paint, varnish, or other coatings shall be permitted on the jointing material until after the joint has been tested and approved.

706.3 Joints for Plastic Pipe and Fittings

Refer to Section 308.8 for ABS and PVC joints. Joints for a polyolefin laboratory drainage system shall be in accord with CAN/CSA-B181.3-M86.

★ 706.4 Elastomeric Compression Gasket for Cast Iron Soil Pipe

706.4.1 A positive-seal one piece elastomeric compression type gasket may be used for joining hub and spigot cast iron soil pipe as an alternate for lead or oakum joints. The joint is formed by inserting an approved gasket in the hub. The inside of the gasket is lubricated and the spigot end of the pipe is pushed into the gasket until seated, thus effecting a positive seal.

706.4.2 A positive-seal one piece elastomeric compression-type gasket for joining hub and spigot cast iron soil pipe may be used for drainage and waste systems above and below ground.

Compression gaskets for cast iron soil pipe shall be neoprene, marked as such, with ASTM C 564.

706.5 Hubless Cast Iron Soil Pipe System

706.5.1 Joints for hubless cast iron soil pipe shall be made with an approved gasket and stainless steel retaining sleeve.

706.5.2 Stainless steel couplings and gaskets complying with standards listed in Table 303 shall have identifying markers to indicate compliance.

706.5.3 Installation of the hubless cast iron soil pipe system shall be in accordance with CISPI 310 or the manufacturer's recommendation.

706.6 Borosilicate Glass Joints

706.6.1 Glass to glass connections shall be made with a bolted compression type stainless steel (300 series) coupling

with contoured acid-resistant elastomer compression ring and a fluorocarbon polymer inner seal ring.

706.6.2 Joints between glass pipe and other types of piping material shall be made with adapters having a TFE seal and according to manufacturer's recommendations.

706.6.3 Caulked joints shall conform with 706.2 except that acid resistant rope and acid proof cement may be used.

706.7 Joints for Ductile-Iron Gravity Sewer Pipe (bell and spigot)

Joints in ductile-iron gravity sewer pipe shall be of the push-on joint type using a single oil resistant gasket joint. The gasket and the annular recess in the bell end of the pipe will be designed and shaped so that the gasket is locked in place against displacement. The oil resistant gaskets shall conform to ANSI/AWWA C111-A21.11 and shall comply with the performance requirements of the standard.

707 USE OF JOINTS

707.1 Clay Sewer Pipe

Joints in vitrified clay pipe or between such pipe and other pipe shall be formed as provided in 308.4, 308.5, or 707.4.

707.2 Concrete Sewer Pipe (for storm drains only)

Joints in concrete sewer pipe or between such pipe and metal pipe shall be formed as prescribed in 308.4, 308.5, or 707.4.

707.3 Cast Iron Soil Pipe

Joints in cast iron pipe shall be either caulked, positive-seal elastomeric compression gasket or a neoprene gasket and stainless steel retaining sleeve, as provided in 308.2, 706.2, 706.4, and 706.5.

707.4 PVC Transition Fittings for Dissimilar Pipe in Building Sewers

707.4.1 PVC transition fittings for dissimilar pipe in building sewers shall be installed according to manufacturers' instructions.

707.4.2 Joint Sealer Adapter – To adapt cast iron, plastic, fiber, asbestos cement, clay or copper pipe to all makes of dissimilar drain pipes with PVC joint.

707.4.3 Flexible Coupling – To adapt any two of the following pipe of the same O.D. or reducing sizes of any combination of two: clay, concrete, cast iron, steel, copper (DWV), asbestos, cement, fiber drain and sewer pipe, plastic drain and sewer pipe.

707.5 Ductile Iron Pipe Without Push-On-Joints (plain end)

Joints in ductile iron pipe for the building sewer without push-on-joints shall be made with a flexible coupling assembly in accordance with 308.4 or in accordance with the manufacturer's instructions.

708 CONNECTIONS BETWEEN DRAINAGE PIPING AND FIXTURES

708.1 Connections between drainage piping and floor outlet plumbing fixtures shall be made by means of an approved flange which is attached to the drainage piping in accordance with the provisions of this chapter. The 4 x 3 closet flange shall be attached to the outside diameter and not to the inside diameter of the drainage piping. The floor flange shall be set on and securely anchored to the building structure.

708.2 Connections between drainage piping and wall hung water closets shall be made by means of an approved extension nipple or horn adapter.

708.3 The connection shall be bolted to the flange or carrier using corrosion resisting bolts, screws or assemblies recommended by the manufacturer.

708.4 An approved gasket, washer, or setting compound shall be used between the fixture and the connection. Use of commercial putty or plaster shall be prohibited as the setting compound.

709 PROHIBITED JOINTS AND CONNECTIONS

709.1 Drainage System

Any fitting or connection which has an enlargement, chamber, or recess with a ledge, shoulder, or reduction of pipe area, that offers an obstruction to flow through the drain, is prohibited, except as stated in 715.

709.2 Prohibited Fittings or Connections

Fittings or connections that offer abnormal obstruction to flow shall not be used. The enlargement of a 3-inch closet bend or stub to 4 inches shall not be considered an obstruction.

710 CLEANOUTS

710.1 Material and Design

The bodies of cleanout ferrules shall conform in thickness to that required for pipe and fittings of the same material, and they shall extend not less than 1/4 inch (6.35 mm) above the hub. For new work, the cleanout plug shall be of heavy brass or plastic not less than 1/8-inch (3.18 mm) thick and shall be provided with a raised nut or a recessed socket for removal. Both ferrule and plug shall have ASME standard tapered pipe threads. Heavy lead plugs may be used for repairing a cleanout where necessary. Nylon plastics may be used as an alternate material.

710.2 Location

710.2.1 Each horizontal drainage pipe shall be provided with a cleanout at the upstream end of the pipe and in changes of direction over 45° (0.785 rad):

EXCEPTIONS: The following plumbing arrangements are acceptable in lieu of the upstream cleanout.

1. "P" traps connected to the drainage piping with slip joints or ground joint connections.
2. "P" traps into which floor drains, shower drains or tub drains with removable strainers discharge.
3. "P" traps into which the straight through type waste and overflow discharge with the overflow connecting to the branch of the tee.
4. "P" traps into which residential washing machines discharge.
5. Test tees or cleanouts in a vertical pipe above the flood-level rim of the fixtures that the horizontal pipe serves and not more than 4 ft (1219 mm) above the finish floor.
6. Cleanout within 6 ft (1829 mm) of the junction of the building drain and the building sewer which may be rodded both ways.
7. Water closets for the water closet fixture branch only.

710.2.2 Each building drain shall be provided with a cleanout within 6 ft (1829 mm) of the junction of the building drain and building sewer.

710.2.3 Cleanouts when installed in accordance with 710.2.2 may be either outside the building or when inside the building they shall be above the flood-level rim of the fixtures that the horizontal pipe serves when installed on a soil or waste stack.

710.2.4 In addition to the upstream cleanout and the cleanout of the junction of the building drain and building sewer, cleanouts shall be located along the horizontal piping so that:

1. In pipe 3-inch nominal diameter or less, cleanouts shall be located at not more than 50 ft (15.2 m) intervals.
2. In pipe 4 inches nominal diameter through 6 inches nominal diameter, cleanouts shall be located at not more than 80 ft (24.4 m) intervals.

710.3 Concealed Piping

Cleanouts on concealed piping or piping under a floor slab or piping in a crawl space of less than 24 inches (610 mm) or a plenum of any depth shall be extended through and terminate flush with the finished wall, floor or grade or may be extended to the outside of the building. Where it is necessary to conceal a cleanout or to terminate a cleanout in an area subject to vehicular traffic, the covering plate, access door or cleanout shall be of the approved type designed and installed for this purpose.

710.4 Direction of Flow

Cleanouts shall be installed to permit cleaning in the direction of flow. Line cleanouts which may be rodded both ways shall be used whenever practical.

710.5 Use for New Fixtures Prohibited

Cleanout plugs shall not be used for the installation of new fixtures or floor drains, except where approved in writing by the plumbing official and where another cleanout of equal access and capacity is provided.

710.6 Trap Cleanouts

710.6.1 Each fixture trap, except those cast integrally or in combination with fixtures in which the trap seal is accessible, or except when a portion of the trap is readily removable for cleaning purposes, shall have an accessible brass trap screw of ample size. Cleanout plugs or caps shall be watertight and gastight. Nylon plastics may be used as an alternate material.

710.6.2 Cleanouts on the seal of a trap shall be made tight with threaded cleanout plug and approved washer. Where glass traps are required, slip joints or couplings must have a TFE seal.

710.7 Manholes

Sewer manholes shall be waterproofed, constructed of poured-in-place concrete or precast concrete pipe sections conforming to ASTM C 478. Bottoms shall be concrete poured on stabilized soil or aggregate subbase with inside surfaces sloped a minimum of 2 inches per foot to the pipe flow channel. All pipe connections and joints shall be sealed with approved waterstop or gasket materials and grouted. Manhole top frames and covers shall be Class 30 gray cast iron conforming to ASTM A 48, machined for proper fit of covers in frame, coated with coal-tar pitch varnish and not less than 93% of the specified weight for each casting. Covers shall have the word "SEWER" cast in large letters. Similar, sealed covers with gaskets and cap screws or bolts shall be used where subject to flooding. (See Appendix J, Figure 13.)

711 SIZE OF CLEANOUTS

711.1 Pipes Less Than 8-inch Nominal Size

Cleanouts shall be the same nominal size as the pipe to which they are connected.

Exceptions:

1. Pipes larger than 4-inch nominal size may be served by a 4-inch cleanout.
2. A 1 1/4-inch "P" trap connected with slip joints or ground joint connections may be used to serve 1 1/2-inch pipe.
3. A 1 1/2-inch "P" trap connected with slip joints or ground joint connections may be used to serve a 2-inch pipe.

711.2 Pipes 8 Inches and Larger Nominal Size

711.2.1 Building drains may be served with a 4-inch cleanout.

711.2.2 For building sewers 8 inches and larger, manholes shall be provided and located at each change in direction and at intervals of not more than 400 ft (121.9 m). Manholes and manhole covers shall conform to 710.7.

711.2.3 Building drains 8-inch nominal size and larger shall have cleanouts located at intervals of not more than 100 ft (30.5 m) and at each change of direction over 45° (0.785 rad).

712 CLEANOUT CLEARANCES

712.1 Small Pipe

Cleanouts smaller than 3 inches shall be so installed that there is a clearance of not less than 12 inches (305 mm) for the purpose of rodding.

712.2 Large Pipe

Cleanouts on 3 inch or larger pipes shall be so located that there is a clearance of not less than 18 inches (457 mm) for the the purpose of rodding.

713 FIXTURE UNITS

713.1 Values for Fixtures

Fixture unit values as given in Table 713.1 designate the relative load weight of different kinds of fixtures which shall be employed in estimating the total load carried by a soil or waste pipe and shall be used in connection with the tables of sizes for soil, waste, and vent pipes for which the permissible load is given in terms of fixture units.

Table 713.1
Fixture Units Per Fixture or Group

Fixture Type	Fixture-Unit Value As Load Factors	Minimum Size of Trap (in)
Bathroom group consisting of water closet, lavatory, and bathtub or shower	6	
Bathtub ¹ (with or without overhead shower) or whirlpool attachments	2	1 1/2
Bidet	2	Nominal 1 1/2
Combination sink and tray	3	1 1/2
Combination sink and tray with food disposal unit	4	Separate traps 1 1/2
Dental unit or cuspidor	1	1 1/4
Dental lavatory	1	1 1/4
Drinking fountain	1/2	1
Dishwashing machine ² domestic	2	1 1/2
Floor drains ⁵	1	2
Kitchen sink, domestic	2	1 1/2
Kitchen sink, domestic with food waste grinder and/or dishwasher	3	1 1/2
Lavatory ⁴	1	Small P.O. 1 1/4
Lavatory ⁴	2	Large P.O. 1 1/2
Lavatory, barber, beauty parlor	2	1 1/2
Lavatory, surgeon's	2	1 1/2
Laundry tray (1 or 2 compartments)	2	1 1/2
Shower stall, domestic	2	2
Showers (group) per head ²	3	
Sinks		
Surgeon's	3	1 1/2
Flushing rim (with valve)	8	3
Service (trap standard)	3	3
Service ("p" trap)	2	2
Pot, scullery, etc. ²	4	1 1/2
Urinal, pedestal, siphon jet, blowout	8	Note 6
Urinal, wall lip	4	Note 6
Urinal, Washout	4	Note 6
Washing machines (commercial) ³		
Washing machine (residential)	3	2
Wash sink (circular or multiple) each set of faucets	2	Nominal 1 1/2
Water closet, flushometer tank, public or private	3	Note 6
Water closet, private installation	4	Note 6
Water closet, public installation	6	Note 6

1 in = 25.4 mm

Notes:

1. A showerhead over a bathtub or whirlpool bathtub attachments does not increase the fixture value.
2. See 713.2 and 713.3 for methods of computing unit value of fixtures not listed in Table 713.1 or for rating of devices with intermittent flows.
3. See Table 713.2.
4. Lavatories with 1 1/4 or 1 1/2-inch trap have the same load value; larger P.O. plugs have greater flow rate.
5. Size of floor drain shall be determined by the area of the floor to be drained. The drainage fixture unit value need not be greater than 1 unless the drain receives indirect discharge from plumbing fixtures, air conditioner or refrigeration equipment.
6. Trap size shall be consistent with fixture type as defined in industry standards.

713.2 Fixtures Not Listed

Fixtures not listed in Table 713.1 shall be estimated in accordance with Table 713.2.

Table 713.2
Fixtures Not Listed

Fixture Drain or Trap Size (in)	Fixture-Unit Value
1 1/4 and smaller	1
1 1/2	2
2	3
3	5
4	6

1 in = 25.4 mm.

713.3 Values for Continuous Flow

For a continuous or semicontinuous flow into a drainage system, such as from a pump, pump ejector, air conditioning equipment, or similar device, two fixture units shall be allowed for each gpm of flow (31.7 fixture units for each liter per second of flow).

713.4 Air Conditioning Units

The condensate or waste from an air conditioning unit shall be classified as a plumbing fixture only if connected to the plumbing system.

714 DRAINAGE SYSTEM SIZING

714.1 Maximum Fixture Unit Load

The maximum number of fixture units that may be connected to a given size of building sewer, building drain, horizontal branch, or vertical soil or waste stack is given in Tables 714.1 and 714.2.

Table 714.1
Building Drains and Sewers

(Maximum Number of Fixture-Units that may be Connected to Any Portion¹ of the Building Drain or the Building Sewer²)

Diameter of Pipe (in.)	Fall in Inches Per Foot			
	1/16	1/8	1/4	1/2
2	-	-	21	26
3	-	20 ³	27 ³	36 ³
4	-	180	216	250
5	-	390	480	575
6	-	700	840	1,000
8	1,400	1,600	1,920	2,300
10	2,500	2,900	3,500	4,200
12	3,900	4,600	5,600	6,700
15	7,000	8,300	10,000	2,000

1 in = 25.4 mm.

Notes:

1. Includes branches of the building drain. The minimum size of any building drain serving a water closet shall be 3".
2. No building sewer shall be less than 4 inches in size
3. Not over two water closets.

Table 714.2
Horizontal Fixture Branches and Stacks

DIAMETER OF PIPE ⁵ (in)	MAXIMUM NO. OF FIXTURE UNITS THAT MAY BE CONNECTED TO:			
	ANY HORIZONTAL FIXTURE BRANCH ^{1,4}	ONE STACK OF 3 STORIES OR 3 INTERVALS MAXIMUM		
		MORE THAN 3 STORIES IN HEIGHT		TOTAL AT ONE STORY OR BRANCH INTERVAL
1 1/4	1	2	2	1
1 1/2	3	4	8	2
2	6	10	24	6
3	20 ²	30 ³	60 ³	16 ²
4	160	240	500	90
5	360	540	1,100	200
6	620	960	1,900	350
8	1,400	2,200	3,600	600
10	2,500	3,800	5,600	1,000
12	3,900	6,000	8,400	1,500
15	7,000	—	—	—

1 in = 25.4 mm

Notes:

1. Does not include branches of the building drain.
2. Not over two water closets.
3. Not over six water closets.
4. 50% less for battery vented fixture branches, no size reduction permitted for battery vented branches throughout the entire branch length.
5. The minimum size of any branch or stack serving a water closet shall be 3".

714.2 Minimum Size of Soil and Waste Stacks

No soil or waste stack shall be smaller than the largest horizontal branch connected thereto except that a 4x3 water closet connection shall not be considered as a reduction in pipe size. The soil or waste stack shall run undiminished in size from its connection to the building drain to its connection to the stack vent.

714.3 Future Fixtures

When provision is made for the future installation of fixtures, those provided for shall be considered in determining the required sizes of drain pipes. Construction to provide for such future installation shall be terminated with a plugged fitting or fittings at the stack so as to form no dead end.

714.4 Underground Drainage Piping

Any portion of the drainage system installed underground or below a basement or cellar shall not be less than 2-inch diameter. In addition, any portion of the drainage system installed underground which is located upstream from a grease trap or grease interceptor as well as the underground horizontal branch receiving the discharge therefrom shall not be less than 3-inch diameter.

715 OFFSETS IN DRAINAGE PIPING IN BUILDINGS OF FIVE STORIES OR MORE

715.1 Offsets of 45 Degrees or Less

An offset in a vertical stack, with a change of direction of 45° (0.785 rad) or less from the vertical, may be sized as a straight vertical stack. In case a horizontal branch connects to

the stack within 2 ft (610 mm) above or below the offset, a relief vent shall be installed in accordance with 917.3, except that when the offset stack is sized for a building drain (see Table 714.1, Column 5) the relief vent may be omitted.

715.2 Above Highest Branch

An offset above the highest horizontal branch is an offset in the stack vent and shall be considered only as it affects the developed length of the vent.

715.3 Below Lowest Branch

In the case of an offset in a soil or waste stack below the lowest horizontal branch, no change in diameter of the stack because of the offset shall be required if it is made at an angle of not greater than 45° (0.785 rad) from the vertical. If such an offset is made at an angle greater than 45° (0.785 rad) from the vertical, the required diameter of the offset and the stack below it shall be determined as for a building drain (Table 714.1).

715.4 Offsets of More Than 45 Degrees

A stack with an offset of more than 45° (0.785 rad) from the vertical shall be sized as follows:

1. The portion of the stack above the offset shall be sized as for a regular stack based on the total number of fixture units above the offset.
2. The offset shall be sized as for a building drain (Table 714.1, Column 5).
3. The portion of the stack below the offset shall be sized as for the offset or based on the total number of fixture units on the entire stack, whichever is larger (See Table 714.2, Column 4).
4. A relief vent for the offset shall be installed as provided in Chapter 9 and in no case shall a horizontal branch connect within the offset or within 2 ft (610 mm) above or below the offset.

715.5 Omission of Offset Reliefs

Offset relief vents required by 715.4 may be omitted by sizing the stack and its offset one pipe size larger than required for a building drain (see Table 714.1, Column 5) but in no case shall the entire stack and offset be of less cross-sectional area than that required for a straight stack plus the area of an offset relief vent as provided in 917.2. Omission of relief vents in accordance with this section shall not constitute approval of horizontal branch connections within the offset or within 2 ft (610 mm) above or below the offset. See 715.1 for offsets of 45° (0.785 rad) or less.

716 WASTE STACKS SERVING KITCHEN SINKS

In a one or two family dwelling only in which the waste stack or vent receives the discharge of a kitchen sink and also serves as a vent for fixtures connected to the horizontal portion of the branch served by the waste stack, the minimum size of the waste stack up to the highest sink branch connection shall be 2-inch diameter. Above that point the size of the stack shall be governed by the total number of fixture units vented by the stack.

717 SUMPS AND EJECTORS

717.1 Building Drains Below Sewer

Building drains which cannot be discharged to the sewer by gravity flow shall be discharged into a tightly covered and vented sump from which the liquid shall be lifted and discharged into the building gravity drainage system by automatic pumping equipment or by any equally efficient method approved by the plumbing official.

717.2 Check and Gate Valve Required

A check valve and a gate valve shall be installed in the pump or ejector discharge piping between the pump or ejector and the gravity drainage system. Such valve shall be accessibly located above the sump cover required by 717.1, or when the discharge pipe from the ejector is below grade, the valves may be accessibly located outside the sump below grade in an access pit with removable access cover.

717.3 Sewage Ejector Sump Construction

Sumps may be constructed of cast iron or monolithically poured reinforced concrete. When concrete sumps are used, a cover attachment ring shall be embedded in the concrete in such a way as to be watertight and gastight. The attachment ring shall be designed to fit the sump cover and allow a gastight and watertight seal to be made. Other engineered sump construction and materials may be accepted by the plumbing official when designed to be watertight and gastight and otherwise meet the requirements of this section.

717.4 Venting

The system of drainage piping below the sewer level shall be installed and vented in a manner similar to that of the gravity system.

717.5 Duplex Equipment

Sumps receiving the discharge of more than six water closets shall be provided with duplex pumping equipment.

717.6 Vent Sizes

Building sump vents shall be sized in accordance with Table 920 but shall in no case be sized less than 1 1/2 inches.

717.7 Separate Vents

Vents from pneumatic ejectors or similar equipment may be carried separately to the open air as a vent terminal (see 915).

717.8 Connections

Direct connection of a steam exhaust, blowoff, or drip pipe shall not be made with the building drainage system. Waste water when discharged into the building drainage system shall be at a temperature not higher than 140°F (60°C). When higher temperatures exist, proper cooling methods shall be provided.

717.9 Pumping Station

717.9.1 A pumping system shall include the sump pump, pit and discharge piping as defined below:

1. Sump Pump: An automatic water pump for the removal of drainage from a sump, pit or low point in

a residential, commercial or industrial property. Capacity and head shall be appropriate to anticipated use requirements.

2. Sump Pit: The sump pit shall be not less than 18 inches (457 mm) diameter and 24 inches (610 mm) deep, unless approved by the plumbing official. The pit shall be accessible and located such that all drainage flows into the pit due to gravity. The sump pit may be constructed of tile, concrete, steel, plastic or other approved materials. The pit bottom shall be solid and provide permanent support for the pump. The sump pit shall be fitted with a removable cover adequate to support anticipated loads in the area of use and to prevent refuse from entering the pit.
3. Discharge piping: Discharge piping shall meet the requirements of 717.2.

717.9.2 Electrical service outlet when required shall meet the requirements of the NFPA 70 or local codes.

717.9.3 Sumps which receive and discharge liquid wastes or raw sewage from plumbing fixtures shall meet the applicable requirements of 717.3.

717.10 Maximum Effluent Level

The effluent level control etc. shall be adjusted and maintained to at all times prevent the effluent in the sump from rising to within 2 inches (51 mm) of the invert of the gravity drain inlet into the sump.

717.11 Ejector Connection to the Drainage System

Pumps when connected to the drainage system shall connect to the building sewer or shall connect to a wye fitting in the building drain a minimum of 10 ft (3048 mm) from the base of any soil stack, waste stack or fixture drain.

717.12 Macerating Systems

Macerating toilet systems shall be installed per the manufacturer's instructions. The outlet piping from the grinder pump shall not be less than 3/4 inch and shall be fitted with a check valve and a full-flow gate or ball valve.

718 APPENDIX REFERENCES

Additional provisions for sanitary drainage are found in the following appendices: Appendix B - Travel Trailers and Travel Trailer Parks; Appendix C - Mobile/Manufactured Homes and Mobile/Manufactured Home Parks; Appendix E - Private Sewage Disposal; Appendix G - Medical Facilities Plumbing Systems; and Appendix I - Installation of Building Sewers. These provisions are applicable only when they are referenced in the body of the code sections or when included in the adopting ordinance.

CHAPTER 8 INDIRECT AND SPECIAL WASTES

801 GENERAL

801.1 Scope

The provisions of this chapter shall govern the materials, design, construction, and installation of indirect and special wastes systems.

★

801.4 Neutralizing Device

In no case shall corrosive liquids, spent acids, or other harmful chemicals which might destroy or injure a drain, sewer, soil or waste pipe, or which might create noxious or toxic fumes, discharge into the plumbing system without being thoroughly diluted or neutralized by passing through a properly constructed and acceptable dilution or neutralizing device. Such device shall be automatically provided with a sufficient intake of diluting water or neutralizing medium, so as to make its contents noninjurious before being discharged into the soil or sewage system.

801.5 Tests

The indirect and special waste system shall be tested in accordance with 311.

802 DEFINITIONS

The following definitions have been moved to Chapter 2: AIR GAP (DRAINAGE SYSTEM), FLOOR SINK.

803 MATERIAL AND SIZE

The material and size of indirect waste piping shall be in accordance with the provisions applicable to sanitary drainage piping in Chapter 7. Acid and chemical indirect waste pipes shall be of materials unaffected by the discharge of such wastes.

804 INDIRECT WASTE CONNECTIONS

804.1 Food Handling

Establishments engaged in the storage, preparation, selling, serving, processing or other handling of food shall have the waste piping from all food handling equipment indirectly connected to the drainage system through an air gap or air break as specified in Section 806. Food handling equipment includes but is not limited to the following: any sink where food is cleaned, peeled, cut up, rinsed, battered, defrosted or otherwise prepared or handled; potato peelers; ice cream dipper wells; refrigerators; freezers; walk-in coolers or freezers; ice boxes; ice making machines; fountain type drink dispensers; rinse sinks; cooling or refrigerating coils; laundry washers; extractors; steam tables; steam kettles; egg boilers; coffee urns; or similar equipment.

EXCEPTION: An air gap is the only acceptable method of indirectly connecting any food handling equipment wherein the indirect waste pipe may be under a vacuum.

804.2 Commercial Dishwashing Machines

Commercial dishwashing machines shall be indirectly connected.

804.3 Connections

804.3.1 Water Supply Connections

Drains, overflows or relief lines from the water supply system shall waste into an indirect waste receptor through an air gap.

804.3.2 Air Conditioning Unit Connections

Indirect waste connections shall be provided for drains, overflows, or relief lines from air conditioning units.

804.4 Sterile Materials

Appliances, devices, or apparatus such as stills, sterilizers, and similar equipment, requiring water and waste connections and used for sterile material, shall be indirectly connected or provided with an air gap between the trap and the appliance.

804.5 Drips

Appliances, devices, or apparatus not regularly classed as plumbing fixtures but which have drips or drainage outlets shall be drained by indirect waste pipes discharging into an open receptacle as provided in 804.1.

805 LIMITATIONS

805.1 Maximum Length

805.1.1 Indirect waste pipe exceeding 2 ft (610 mm) long shall be trapped.

805.1.2 The maximum length of the indirect waste to indirect waste receptor shall not exceed 15 ft (4527 mm).

805.2 Cleaning

Indirect waste piping shall be so installed as to permit ready access for flushing and cleansing.

806 INDIRECT WASTE METHODS

806.1 Air gap

The air gap between the indirect waste and the building drainage system shall be at least twice the diameter of the effective opening of the indirect waste pipe, but in no case less than 2 inches (51 mm), and shall be provided by extending the indirect waste pipe to an open, accessible floor sink, service sink, floor drain, hub drain or other suitable fixture which is properly trapped and vented. The indirect waste pipe shall terminate a sufficient distance above the

flood level rim of the sink or receptor to provide the minimum required air gap and shall be installed in accordance with other applicable sections of this code.

806.2 Air break

The air break between the indirect waste and the building drainage system shall be installed such that the level of the lowest outlet located on the fixture, device, appliance or apparatus (to which the indirect waste pipe connects) is above the flood level rim of the receiving sink or other receptor by a vertical distance of at least twice the diameter of the effective opening of the indirect waste pipe, but in no case less than 2 inches (51 mm). In addition, the indirect waste pipe shall terminate below the flood level rim of the receiving sink or other receptor a distance equal to not more than $\frac{1}{2}$ the diameter of the effective opening of the indirect waste pipe.

806.3 Cleanliness

The sink or receptor receiving indirect wastes shall be water-supplied if the waste stream contains or is expected to contain a sufficient amount of organic matter capable of causing odors or otherwise causing a nuisance due to an insufficient dilution of the waste material discharged into the sink or receptor.

807 INDIRECT WASTE METHODS

807.1 Receptors

807.1.1 Installation. Waste receptors serving indirect waste pipes shall not be installed in any toilet room, nor in any inaccessible or unventilated space such as a closet or storeroom.

807.1.2 Strainers and Baskets. Every indirect waste receptor receiving discharge containing particles that would clog the receptor shall be equipped with a basket or other device which shall prevent passage into the drainage system of solids $\frac{1}{2}$ inch (12.7 mm) or larger in size. The basket or device shall be removable for cleaning purposes.

807.1.3 Splashing. All plumbing receptors receiving the discharge of indirect waste pipes shall be of such shape and capacity as to prevent splashing or flooding. No plumbing fixture which is used for domestic or culinary purposes shall be used to receive the discharge of an indirect waste pipe.

807.2 Clear Water Wastes

Water lifts, expansion tanks, cooling jackets, sprinkler systems, drip or overflow pans, or similar devices which waste clear water only, shall discharge into the building drainage system through an indirect waste.

807.3 Hot Water Drainage

A steam pipe shall not connect directly to any part of a drainage system, nor shall any water above 140°F (60°C) be discharged directly into any part of a drainage system.

807.4 Drinking Fountains

Drinking fountains may be installed with indirect wastes.

807.5 Swimming Pools

Piping carrying waste water from swimming or wading pools, including pool drainage, backwash from filters, water from scum gutter drains or floor drains which serve walks around pools, shall be installed as an indirect waste utilizing a circulation pump, if necessary, when indirect waste line is below the sewer grade.

808 APPENDIX REFERENCES

Additional provisions for indirect and special wastes are found in the following appendices: Appendix B - Travel Trailers and Travel Trailer Parks; Appendix C - Mobile/Manufactured Homes and Mobile/Manufactured Home Parks; Appendix E - Private Sewage Disposal; Appendix G - Medical Facilities Plumbing Systems. These provisions are applicable only when they are referenced in the body of the code sections or when included in the adopting ordinance.

CHAPTER 9 VENTS

901 GENERAL

901.1 Scope

The provisions of this chapter shall govern the materials, design, construction, and installation of vents.

901.2 Protection of Trap Seals

The protection of trap seals from siphonage or back pressure shall be accomplished by the appropriate use of soil or waste stacks, vent, revents, back vents, loop vents, circuit or continuous vents or combination thereof, installed in accordance with the requirements of this chapter and the limitations set forth in Section 303.8.3.

901.4 Tests

The venting system shall be tested in accordance with 311.2.

901.5 Engineered Systems

Engineered sanitary drainage and venting systems shall conform to the provisions of Chapter 12, Alternate Designed Plumbing Systems.

902 DEFINITIONS

902.1 The following definition has been deleted without substitution: AIR ADMITTANCE VALVE.

902.2 The following definitions have been moved to Chapter 2: ACCESS COVER, BATTERY VENTING, BRANCH INTERVAL, BRANCH VENT, CIRCUIT VENT, COMMON VENT, CONTINUOUS VENT, CROWN OF TRAP, DEPTH OF WATER SEAL, INDIVIDUAL VENT, LOOP VENT, MAIN VENT, RESIDENTIAL BUILDINGS, SIDE VENT, WET VENT, YOKE VENT.

902.3 The following definitions have been moved to Appendix L: DISCHARGE PIPE, DISCHARGE UNIT, VENTILATING PIPE.

903 MATERIALS

903.1 Vents

Pipe, tubing, and fittings for the vent piping system shall comply with the provisions of Chapter 7.

903.2 Specific Type

Standards given in Table 703 apply to the specific materials approved for use and as indicated in the various sections in this chapter.

903.3 Piping Above Ground

Vent piping shall be of cast iron, galvanized steel, brass or copper pipe, copper tube of a weight not less than that of

copper drainage tube Type DWV, Schedule 40 plastic piping, or borosilicate glass.

903.4 Piping Underground

Vent piping placed underground shall be of cast iron, copper tube of a weight not less than that of Type DWV, Schedule 40 plastic piping or heavy schedule borosilicate glass, provided that other materials may be used for underground vents when found adequate and installed as directed by the Plumbing Official. Materials subject to corrosion shall be protected when installed in corrosive soil.

903.5 Fittings

Fittings shall be compatible to the type of pipe used in the vent system as required by 903.2 and 903.3.

903.6 Acid System

Vent piping on acid-waste systems shall conform to 703.6.

904 VENT STACKS

904.1 Installation

A vent stack or main vent shall be installed with a soil or waste stack whenever back vents, relief vents or other branch vents are required in two or more branch intervals. No fixture shall be permitted to drain into any stack above any vent connection.

904.2 Terminal

The vent stack shall terminate independently above the roof of the building or shall be connected with the extension of the soil or waste stack (stack-vent) at least 6 inches (152 mm) above the flood-level rim of the highest fixture.

904.3 Main Stack

904.3.1 Every building in which plumbing is installed shall have at least one main vent stack or stack vent, of not less than 3-inch (76 mm) diameter, for each building drain, when connected separately to a building sewer, septic tank, or other disposal system approved by the plumbing official. Such vent shall run undiminished in size and as directly as possible from the building drain through to the open air above the roof.

904.3.2 The main vent stack in a detached garage or other accessory building where only a washing machine or laundry tray is installed may be 1 1/2 inches (38 mm).

905 VENT TERMINALS

905.1 Roof Extension

Extensions of vent pipes through a roof shall be terminated at least 6 inches (152 mm) above the roof, except that where a roof is to be used for any purpose other than weather protection,

the vent extension shall be run at least 7 ft (2134 mm) above the roof.

905.2 Frost Closure

Where there is possibility of frost closure, the vent extension through a roof shall be at least 3-inch diameter. When it is found necessary to increase the size of the vent terminal, the change in diameter shall be made at least 1 ft (305 mm) inside the building.

905.3 Flashings

The juncture of each vent pipe with the roof line shall be made watertight by proper flashing.

905.4 Flag Poling

Vent terminals shall not be used to support flag poles, TV aerials, or similar items, except when the piping has been anchored to the construction and approved as safe by the plumbing official.

905.5 Location of Vent Terminal

A vent terminal from a drainage system shall not be located directly beneath any door, window or other fresh air intake opening of the building or of an adjacent building, nor shall any such vent terminal be within 10 ft (3048 mm) horizontally of such an opening unless it is at least 2 ft (610 mm) above the top of such opening.

905.6 Extensions Through Wall

Vent terminals extending through a wall shall terminate at least 6 inches (152 mm) above the roof and the opening shall face upward. Vent terminals shall not terminate under the overhang of the building.

905.7 Air Admittance Valves for Venting Plumbing Fixtures and Fixture Branches

Air admittance valves are not approved for venting of plumbing fixture traps.

906 VENT GRADES AND CONNECTIONS

906.1 Grade

All vent and branch vent pipes shall be so graded and connected as to drip back to the soil or waste pipe by gravity.

906.2 Vertical Rise

906.2.1 Where vent pipes connect to a horizontal soil or waste pipe, the vent shall be taken off above the center line of the soil pipe, and the vent pipe shall rise vertically, or at an angle not exceeding 45° (0.785 rad) from the vertical, before offsetting horizontally.

906.2.2 Where vent pipes connect at or below the lowest fixture connection, to a vertical soil or waste pipe, such vent shall be taken off at an angle not exceeding 45° (0.785 rad) to the vertical to a point at least 6 inches (152 mm) above the flood level rim of the lowest fixture it is venting before offsetting horizontally.

906.3 Height Above Fixtures

A connection between a vent pipe and a vent stack or stack vent shall be made at least 6 inches (152 mm) above the flood level rim of the highest fixture served by the vent. Horizontal vent pipes forming branch vents, relief vents, or loop vents shall be at least 6 inches (152 mm) above the flood level rim of the highest fixture served

907 BAR AND FOUNTAIN SINK TRAPS

Traps serving sinks which are part of the equipment of island bars, island soda fountains, island counters and similar equipment need not be conventionally vented when the location and construction of such bars, soda fountains and counters make it impossible to do so. When these conditions exist, traps which are roughed in above the floor shall be vented by extending the vent as high as possible, but not less than the drainboard height and then returning it downward and connecting it to the horizontal sink drain immediately downstream from the vertical fixture drain. The return vent shall be connected to the horizontal branch through a wye-branch fitting and shall, in addition, be provided with a foot vent taken off the vertical fixture vent by means of a wye-branch immediately below the floor and extending to the nearest partition and then through the roof to the open air or may be connected to other vents at a point not less than 6 inches (152 mm) above the flood level rim of the fixtures served. Drainage fittings shall be used on all parts of the vent below the floor level and a minimum slope of 1/4 inch per foot back to the drain shall be maintained. The return bend used under the drainboard shall be a 45 degrees, a 90 degrees and a 45 degrees elbow in the order named. Pipe sizing shall be as elsewhere in this code. The island sink drain, upstream of the returned vent, shall serve no other fixtures. An accessible cleanout shall be installed in the vertical portion of the foot vent. For food service establishments, drainage shall be in accordance with 804.1.

SPECIAL VENTING FOR ISLAND SINK

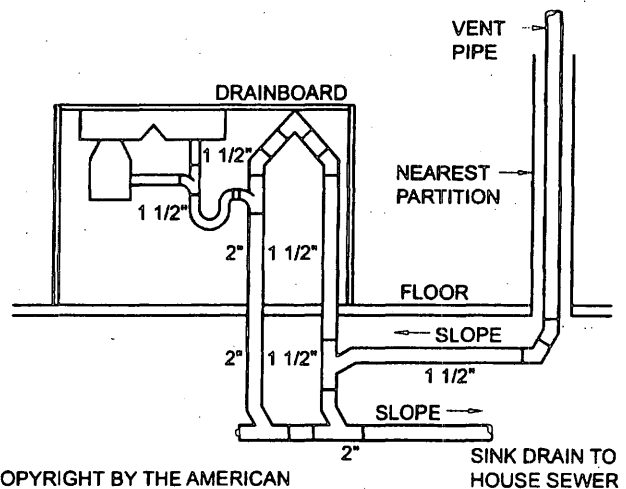

(COPYRIGHT BY THE AMERICAN SOCIETY OF SANITARY ENGINEERING (ASSE) - FIG 4.6 OF ASSE'S RESIDENTIAL PLUMBING INSPECTOR'S MANUAL. USED WITH PERMISSION)

Figure 907.A

908 FIXTURE VENTS

Table 908.1
Distance of Fixture Trap from Vent

908.1 Distance of Trap from Vent

Each fixture trap shall have a protecting vent so located that the slope and the developed length in the fixture drain from the trap weir to the vent fitting are within the requirements set forth in Table 908.1, except as permitted by 913.1. (See Figure 908.1.)

Size of Fixture Drain (in)	Size of Trap (in)	Fall (in/ft)	Max. Distance From Trap
1 1/4	1 1/4	1/4	3 ft 6 in
1 1/2	1 1/4	1/4	5 ft
1 1/2	1 1/2	1/4	5 ft
2	1 1/2	1/4	6 ft
2	2	1/4	8 ft
3	3	1/8	10 ft
4	4	1/8	12 ft

1 in = 25.4 mm
1 ft = 0.3048 m

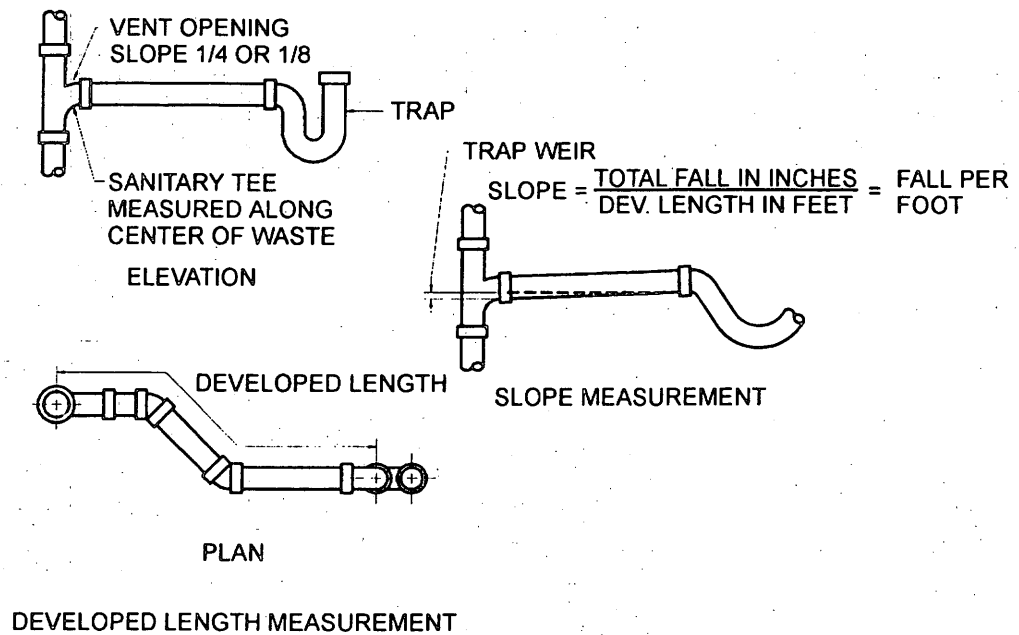

Figure 908.1
Distance of Fixture Trap From Vent

908.2 Trap Seal Protection

The plumbing system shall be provided with a system of vent piping which will permit the admission or emission of air so that under normal and intended use the seal of any fixture trap shall not be subjected to a pressure differential of more than 1 inch of water (249 Pa).

908.3 Trap Dip

The vent pipe opening from a soil or waste pipe, except for water closets and similar fixtures, shall not be below the top weir of the trap.

908.4 Crown Vent

A vent shall not be installed within two pipe diameters of the trap weir.

909 COMMON VENT

909.1 Individual Vent

An individual vent, installed vertically, may be used as a common vent for two fixture traps when both fixture drains connect with a vertical drain at the same level.

909.2 Fixtures on Same Floor

A common vent may be used for two fixtures set on the same floor level but connecting at different levels in the stack, provided the vertical drain is one pipe size larger than the upper fixture drain but in no case smaller than the lower fixture drain, whichever is the larger, and that both drains conform to Table 908.1.

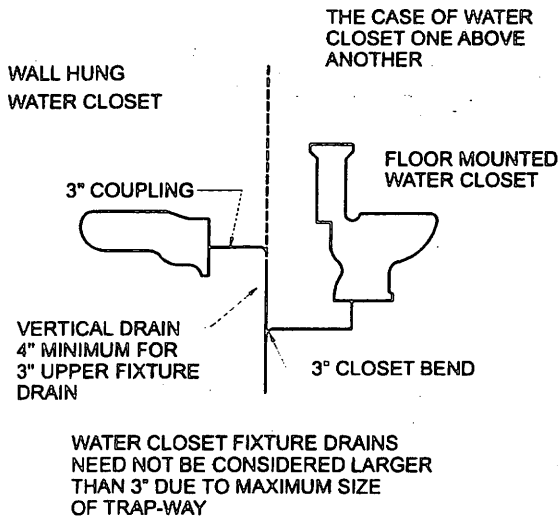

Common Vent
Figure 9-29A

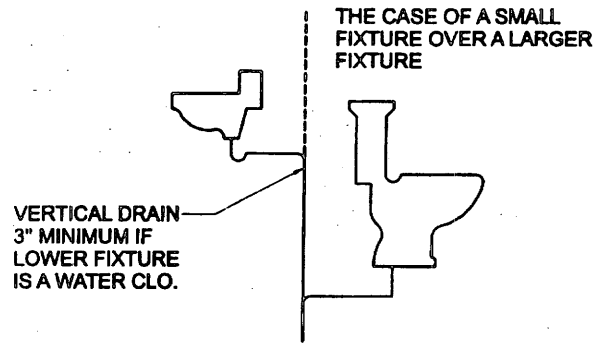

IN ANY CASE THE VERTICAL DRAIN MUST BE ONE PIPE SIZE LARGER THAN THE UPPER FIXTURE DRAIN BUT IN NO CASE SMALLER THAN THE LOWER FIXTURE DRAIN

Common Vent
Figure 9-29B

909.3 Distance

909.3.1 Two fixtures set back-to-back, or side by side within the distance allowed between a trap and its vent, may be served with one continuous soil or waste vent-pipe, provided that each fixture wastes separately into an approved double fitting having inlet openings at the same level. (See 909.2.)

909.3.2 When not more than two fixtures are set back-to-back or side-by-side, within the distance allowed between a trap and its vent, they may be connected to a common horizontal branch served by a common vertical vent located between the two fixtures, provided the branch is one pipe size larger than either of the fixture drains, except as permitted by 913.1. This vent shall not serve as a waste for any other fixture.

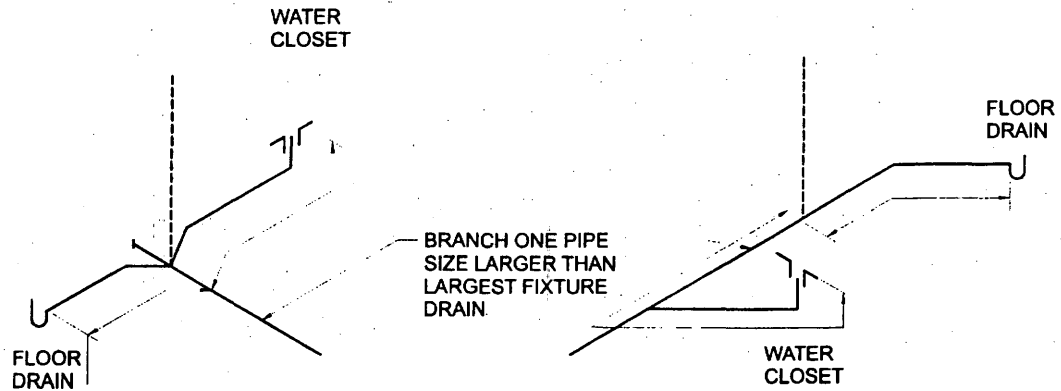

ALL MEASUREMENTS ALONG THE CENTER LINE

Common Vent
Figure 9-31

909.3.3 For the purpose of this section, 3-inch (76 mm) or 4-inch (102 mm) floor or shower drains, 4-dfu water closets or pedestal urinals shall be considered as having 3-inch (76 mm) drains. For more than two fixtures on a common horizontal branch, see 914.1.

910 VENTS FOR FIXTURE TRAP BELOW TRAP DIP

910.1 Hydraulic Gradient

Fixture drains shall be vented within the hydraulic gradient between the trap outlet and vent connection, but in no case shall the unvented drain exceed the distance provided for in Table 908.1.

910.2 Different Levels

If any stack has fixtures entering at different levels, the fixtures other than the fixture entering at the highest level shall be vented, except as may be permitted in other sections of this chapter.

911 WET VENTING

911.1 Single Bathroom Groups

A single bathroom group of fixtures may be installed with the drain from a back vented lavatory, kitchen sink or combination fixture serving as a wet vent for a bathtub or shower stall and for the water closet, provided that the wet vent is one pipe size larger than the upper fixture drain but in no case smaller than the lower fixture drain, whichever is the larger, and that both drains conform to Table 908.1. No urinals or washing machine drain shall discharge into any wet vent.

911.2 Double Bath

Bathroom groups back-to-back on top floor consisting of two bathtubs or shower stalls may be installed on the same horizontal branch with a common vent for the lavatories and with no back vent for the bathtubs or shower stalls and for the water closets, provided that the wet vent is one pipe size larger than the upper fixture drain but in no case smaller than the lower fixture drain, whichever is the larger, and that both

drains conform to Table 908.1. No urinals or washing machine drain shall discharge into any wet vent.

911.3 Multistory Bathroom Groups

On the lower floors of a multistory building, the waste pipe from one or two lavatories may be used as a wet vent for one or two bathtubs or showers provided that:

1. The wet vent and its extension to the vent stack is not less than 2-inch (51 mm) diameter, and
2. Each water closet below the top floor is individually back vented, and
3. The vent stack is sized in accordance with Table 911.3.

Table 911.3
Size of Vent Stack

Number of Wet Vented Fixtures	Diameter of Vent Stacks (in.)
1 or 2 bathtubs or showers	2
3 to 5 bathtubs or showers	2 1/2
6 to 9 bathtubs or showers	3
10 to 16 bathtubs or showers	4

1 in = 25.4 mm

912 STACK VENTING

912.1 Fixture Groups

A single bathroom group of fixtures, consisting of a water closet, basin, shower or tub and a kitchen sink (with disposal and dishwasher) located back-to-back to the bathroom, or two bathrooms back-to-back each consisting of one toilet, basin, shower or tub may be installed without individual fixture vents in a one story building or on the top floor of a building provided each fixture drain connects independently to the stack and that the tub and/or shower and water closet enter the stack at the same level and in accordance with the requirements in Table 908.1. The wet vent portion of the stack vent shall be one pipe size larger than the upper fixture drain but in no case smaller than the lower fixture drain, whichever is the larger.

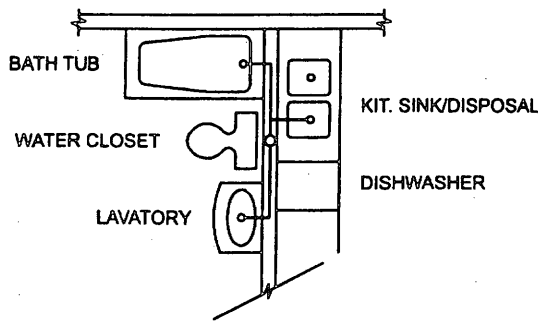

Stack Venting
Figure 9-37

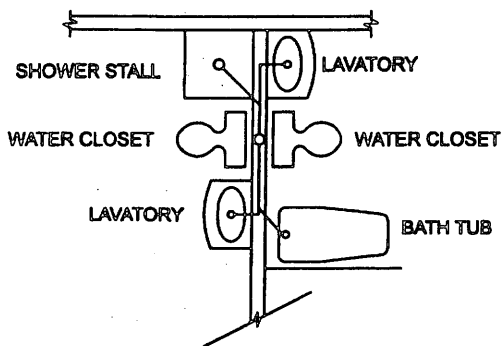

Stack Venting Double Bathroom Groups
Figure 9-38

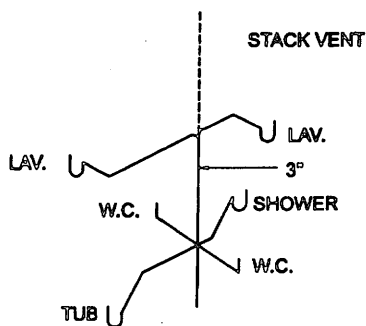

Stack Vent Lower Floors
Figure 9-39

913 INDIVIDUAL FIXTURE REVENTING

913.1 Horizontal Branches

913.1.1 One sink and one lavatory or one tub, or one shower, or three lavatories within 8 ft (2438 mm) developed length of a main vented line may be installed on a 2-inch horizontal waste branch, or two lavatories within 5 ft (1524 mm) developed length of a main vented line may be installed on a 1 1/2-inch horizontal waste branch, without reventing, provided the branch is full size throughout its length, and provided the wastes are connected with a pitch of not more than 1/4 inch per ft (21 mm per meter), and provided that a 2-inch "P" trap shall be the minimum for tubs and showers.

913.1.2 Waste openings in the horizontal branch shall not be less than 1 1/4 inches for lavatories and 1 1/2 inches for a sink. One drinking fountain shall be considered as one lavatory.

913.2 Where Required

All fixtures discharging downstream from a water closet shall be individually vented.

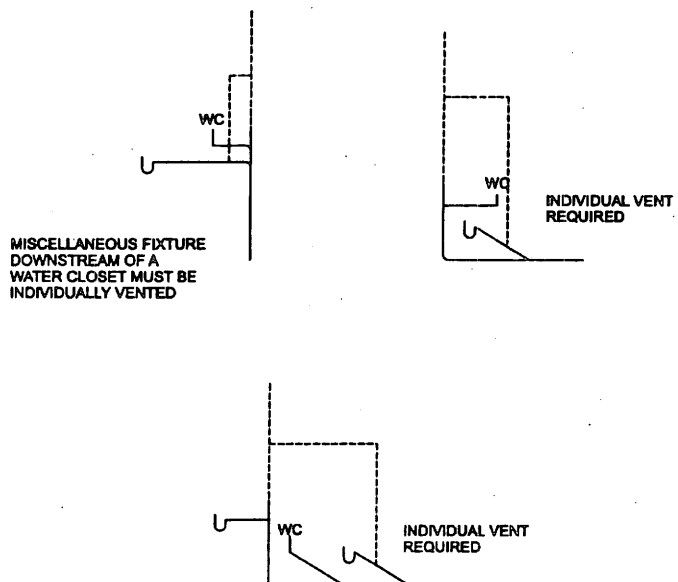

Required Individual Vents
Figure 9-41

912.2 Lower Floors

Lower floors may be vented as in 912.1 provided that a separate wye and upright one-eighth bend is installed in the stack and that the stack group is installed above the one-eighth bend and that a 2-inch (51 mm) vent is installed 6 inches (152 mm) above the flood line of the top fixture.

913.3 Limits of Fixture Units Above Bathtubs and Water Closets

A total of three fixture units may be placed on a soil or waste stack on floors above the highest water closet or bathtub connection without the use of revents provided:

1. The soil or waste stack is not less than 3-inch diameter.
2. The total fixture unit load on the stack does not exceed the limitations of Table 714.2.
3. The largest fixture drain opening into the stack does not exceed the nominal diameter of the trap of the fixture to be connected except as permitted in 913.1. Such opening for multiple fixture connections shall be limited to use on one floor only.
4. Each fixture above the highest tub or water closet is no farther from the stack than permitted in Table 908.1.
5. All fixtures on lower floors are vented as otherwise required by this chapter.

914 CIRCUIT AND LOOP VENTING

914.1 Battery Venting

A branch soil or waste pipe of uniform diameter throughout its length, to which are connected in battery a number of fixtures not exceeding 50% of the fixture units allowed by column two of Table 714.2, may be vented by a circuit or loop vent system connected in front of the last upstream fixture drain. In addition, battery vented branches serving three or more fixtures shall be provided with a relief vent connected in front of the first fixture connection. When lavatories or similar fixtures having a fixture unit rating of four or less and a maximum 2-inch fixture drain discharge from above such branches, each vertical branch shall be provided with a continuous vent. Fixtures having fixture unit ratings greater than four shall not discharge into such branch from above unless all fixtures in the battery group are individually vented. Fixtures from an upper floor shall not discharge into a battery vented branch. Floor level fixtures, including but not limited to floor drains, discharging downstream from a water closet shall be individually vented.

EXCEPTION: The relief vent may be omitted provided a stack vent or vent stack is located downstream of the first horizontal fixture connection.

914.2 Vent Connections

When the circuit, loop, or relief vent connections are taken off the horizontal branch, the vent branch connection shall be taken off at a vertical angle or from the top of the horizontal branch.

Exception: The vent branch connection may be taken off horizontally provided it is washed by not more than four fixture units, other than water closets, and the wet portion of the vent is not smaller than the horizontal battery branch.

914.3 Fixtures Back-to-Back in Battery (See Figure 914.3)

914.3.1 A fixture connected to a horizontal branch through a vertical drain and a sanitary tee shall be vented in accordance with 908.1.

914.3.2 Back-to-back fixtures connected to a horizontal branch through a single vertical drain shall enter the drain through a sanitary cross, and a common vent for each two fixtures shall be provided. The common vent shall be installed as a continuation of the vertical drain.

914.3.3 A fixture connected to a horizontal branch through a wye or combination wye and one-eighth bend installed in a horizontal position need not be individually vented.

914.3.4 Back-to-back fixtures connected to a horizontal branch through a double wye or combination double wye and one-eighth bend installed in the horizontal position need not be provided with a common vent at the connection to the horizontal branch, except for the last two fixtures upstream. The vent shall be installed in a vertical position through a side inlet fitting.

914.3.5 In spite of sections 914.3.3 and 914.3.4, all floor level fixtures, including but not limited to floor drains, discharging downstream from a water closet shall be individually vented.

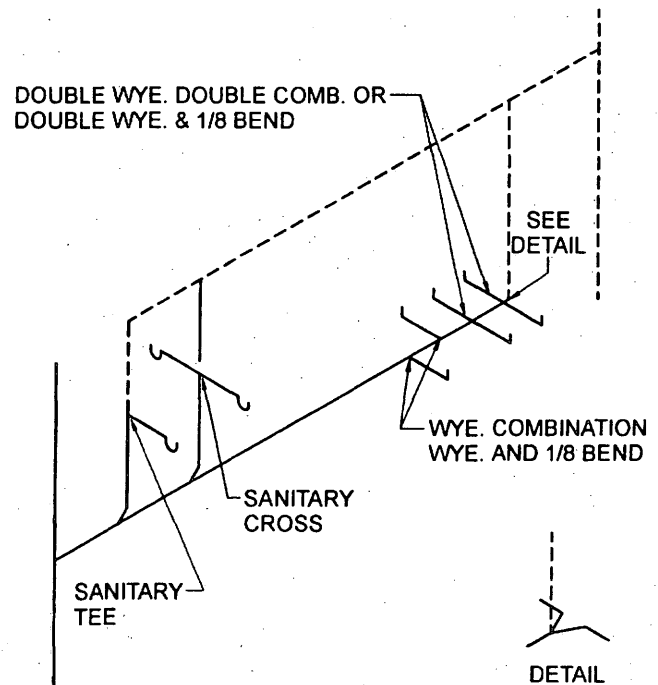

FIGURE 914.3
FIXTURES BACK-TO-BACK IN BATTERY

915 PNEUMATIC EJECTORS

Relief vents from a pneumatic ejector shall be carried separately to the open air.

916 RELIEF VENTS—STACKS OF MORE THAN 10 BRANCH INTERVALS

Soil and waste stacks in buildings having more than ten branch intervals shall be provided with a relief vent at each tenth interval installed, beginning with the top floor. The size

of the relief vent shall be equal to the size of the vent stack to which it connects. The lower end of each relief vent shall connect to the soil or waste stack through a wye below the horizontal branch serving the floor, and the upper end shall connect to the vent stack through a wye not less than 3 ft (914 mm) above the floor.

917 OFFSET VENTS

917.1 General

In buildings five or more stories in height, offsets in vertical drainage piping having less than a 45° (0.785 rad) slope shall be vented in accordance with 917.2 or 917.3, except as otherwise permitted by 715.

917.2 Separate Venting

Such offsets may be vented as two separate soil or waste stacks, namely the stack section below the offset and the stack section above the offset.

917.3 Offset Reliefs

Such offsets may be vented by installing a relief vent as a vertical continuation of the lower section of the stack or as a side vent connected to the lower section between the offset and next lower fixture or horizontal branch. The upper section of the offset shall be provided with a yoke vent. The diameter of the vents shall be not less than the diameter of the main vent, or of the soil and waste stack, whichever is the smaller.

918 MAIN VENTS TO CONNECT AT BASE

All main vents or vent stacks shall connect full size at their base to the building drain within ten pipe diameters of the main soil or waste pipe or to the main soil or waste pipe, at or below the lowest fixture branch. All vent pipes shall extend undiminished in size to the vent terminal, or shall be reconnected with the main soil or waste vent.

919 VENT HEADERS

Stack vents and vent stacks may be connected into a common vent header at the top of the stacks and then terminate as required by this code. This header shall be sized in accordance with the requirements of Table 920.2, the number of units being the sum of all units on all stacks connected thereto, and the developed length being the longest vent length from the intersection at the base of the most distant stack to the vent terminal as a direct extension of one stack.

920 SIZE AND LENGTH OF VENTS

920.1 Length of Vent Stacks

The length of the vent stack or main vent shall be its developed length from the lowest connection of the vent system with the soil stack, waste stack, or building drain to the vent stack terminal, if it terminates separately, or to the connection of the vent stack with the stack vent, plus the developed length of the stack-vent from the connection to the terminal, if the two vents are connected together with a single extension.

920.2 Size of Stack-Vents, Vent Stacks, Relief Vents, Individual Vents or Branch Vents

The diameter of a stack-vent, vent stack, relief vent, individual vent or branch vent shall not be less than one-half of the diameter of the drain served, but in no case less than 1 1/4 inches, and shall be determined from its length and the total of fixture units connected thereto, as provided in Table 920.2. All water closets vents shall be a minimum of 2 inches in diameter. This shall not be interpreted to allow the alteration or elimination of the need for at least one 3 inch vent stack or stack vent on the building drain as required under 904.3.1.

920.3 Size of Battery Vents

The diameter of a battery vent shall be not less than one-half the pipe size of the horizontal waste line it is venting, but in no case less than 1 1/2 inches, and shall be determined from its length and the total of fixture units connected thereto, as provided in Table 920.3. The diameter and horizontal length of a battery vent shall in no case be less than permitted in Table 920.3. (See 914.)

Table 920.2
Maximum Length of Vents
(Other than Battery Vents) (ft)
(See Table 920.3 for Battery Venting)

Size of Soil or Waste Stack (in)	Fixture Units Connected	Diameter of Vent Required (in)								
		1 1/4	1 1/2	2	2 1/2	3	4	5	6	8
1 1/4	2	30								
1 1/2	8	50	150							
1 1/2	10	30	100							
2	12	30	75	200						
2	20	26	50	150						
2 1/2	42	—	30	100	300					
3	10	—	30	100	200	600				
3	30	—	—	60	200	500				
3	60	—	—	50	80	400				
4	100	—	—	35	100	260	1000			
4	200	—	—	30	90	250	900			
4	500	—	—	20	70	180	700			
5	200	—	—	—	35	80	350	1000		
5	500	—	—	—	30	70	300	900		
5	1100	—	—	—	20	50	200	700		
6	350	—	—	—	25	50	200	400	1300	
6	620	—	—	—	15	30	125	300	1100	
6	960	—	—	—	—	24	100	250	1000	
6	1900	—	—	—	—	20	70	200	700	
8	600	—	—	—	—	—	50	150	500	1300
8	1400	—	—	—	—	—	40	100	400	1200
8	2200	—	—	—	—	—	30	80	350	1100
8	3600	—	—	—	—	—	25	60	250	800
10	1000	—	—	—	—	—	—	75	125	1000
10	2500	—	—	—	—	—	—	50	100	500
10	3800	—	—	—	—	—	—	30	80	350
10	5600	—	—	—	—	—	—	25	60	250

1 in = 25.4 mm
1 ft = 0.3048 m

Table 920.3
Battery Vent Sizing Table
Maximum Horizontal Length (ft)

Soil or waste pipe diam. (in)	Maximum no. Fixture units	Diameter of circuit or loop vent (in)					
		1 1/2	2	2 1/2	3	4	5
2	3	15	40				
2 1/2	6	10	30				
3	10	—	20	40	100		
4	80	—	7	20	52	200	
5	180	—	—	—	16	70	200

1 in = 25.4 mm
1 ft = 0.3048 m

★
924 APPENDIX REFERENCES

Additional provisions for vents are contained in Appendix G - Medical Facilities Plumbing Systems and Appendix J - Illustrations. These provisions are applicable only where specifically included in the body of the code sections or in the adopting ordinance.



CHAPTER 10 TRAPS

1001 GENERAL

1001.1 Scope

The provisions of this chapter shall govern the materials and installation of traps.

1001.2 Trap Seal

Each fixture trap shall have a water seal of not less than 2 inches (51 mm) and not more than 4 inches (102 mm), except where a deeper seal is required by the plumbing official for special conditions.

1001.3 Trap Level and Protection

Traps shall be set level with respect to their water seals.

1001.4 Traps Underground

Underground traps, except "P" traps into which floor drains with removable strainers discharge, shall be provided with accessible and removable cleanouts.

1001.5 Prohibited Traps

1001.5.1 A trap which depends for its seal upon the action of movable parts shall not be used.

1001.5.2 "S" traps shall be prohibited, except for water closets, clinic sinks, urinals and similar fixtures with integral traps.

1001.5.3 Bell traps shall be prohibited.

1001.5.4 Crown-vented traps shall be prohibited.

1001.5.5 Baffled or partition traps other than stainless steel, glass, plastic or similar corrosion resistant materials shall be prohibited.

1001.5.6 Tubular metallic traps of less than 20 gage [0.0320 inch (0.813 mm)] thickness shall be prohibited.

1001.5.7 Running traps shall be prohibited.

1001.6 Double Trapping

A fixture shall not be double trapped.

EXCEPTION: Fixtures in mobile/manufactured homes and travel trailers are allowed to be double trapped when a trailer trap is required to be placed in the building sewer/sewer lateral as per 1003.5, B108.10, B112, C107.5.1 or C112.

1001.7 Unions (Threaded)

Unions may be used in the trap seal and on the inlet side of the trap. Unions shall have metal-to-metal seats.

1001.8 Number of Traps Per Fixture

1001.8.1 Plumbing fixtures, excepting those having integral traps, shall be separately trapped by a water seal trap, placed as close to the fixture outlet as possible.

1001.8.2 A combination plumbing fixture may be installed on one trap, if one compartment is not more than 6 inches (152 mm) deeper than the other and the waste outlets are not more than 30 inches (762 mm) apart.

1001.8.3 One trap may be installed for a set of not more than three single-compartment sinks or laundry trays or three lavatories immediately adjacent to each other in the same room, if the waste outlets are not more than 30 inches (762 mm) apart and the trap is centrally located when three compartments are installed.

1001.9 Distance of Trap to Fixture

1001.9.1 The vertical distance from the fixture outlet to the trap weir, or from the outlet of an integrally trapped water closet or similar fixture to the horizontal piping connecting the fixture to its vent, shall not exceed 24 inches (610 mm), except for washing machine (laundry) drains where such distance shall not exceed 48 inches (1219 mm).

1001.9.2 The distance from a vertical standpipe inlet for a washing machine drain to the trap weir shall be a minimum of 30 inches (762 mm) with the vertical standpipe inlet a minimum of 34 inches (864 mm) above finished floor or in accordance with the manufacturer's recommendation.

1002 DEFINITIONS

This chapter contains no unique definitions. For general definitions, see Chapter 2.

1003 TYPE AND SIZE OF TRAPS AND FIXTURE DRAINS

1003.1 Trap Size

The size (nominal diameter) of a trap for a given fixture shall be sufficient to drain the fixture rapidly but in no case less than given in Table 713.1.

1003.2 Relation to Fixture Drains

A trap shall not be larger than the fixture drain to which it is connected.

1003.3 Type of Traps

1003.3.1 Fixture traps shall be self-cleaning, other than integral traps, without partitions or movable parts, except as specifically approved in other sections of this code.

1003.3.2 Slip joints may be used on both sides of the trap and in the trap seal.

1003.3.3 A trap which is integral with the fixture shall have a uniform interior and a smooth waterway.

1003.4 Drum Traps

1003.4.1 Drum traps shall be limited to special fixtures designed for drum traps and are subject to approval by the plumbing official. They shall be not less than 4-inch diameter and shall have a water seal of not less than 2 inches (51 mm).

1003.4.2 The trap screw shall be one size less than the trap diameter.

1003.5 Trailer Traps

Mobile/manufactured homes and travel trailers shall be provided with a trailer trap in the building sewer/sewer lateral immediately downstream of the mobile/manufactured home or travel trailer drain outlet connection. The trailer trap shall be individually vented and the vent shall be located downstream of the trap at a distance in accord with Table 908.1. Running traps are prohibited for this installation. (See diagram under B112 or C112.)

EXCEPTION: The trailer trap for a mobile/manufactured home or travel trailer is not required to be provided with an individual vent if the mobile/manufactured home or travel trailer is connected to a park drainage system constructed in accord with B108.7 and the building sewer/sewer lateral is no longer than 30 feet (9144 mm) from the main park drainage sewer. (See B108.10 and C107.5.1)

TRAILER TRAP AND VENT

- APPROVED MATERIALS FOR TRAP AND VENT**
- (1) CAST IRON PIPE AND FITTINGS.
 - (2) ABS OR PVC PLASTIC PIPE AND FITTINGS SCH. 40
 - (NOTE: DO NOT MIX ABS AND PVC PIPE AND/OR FITTINGS.)

- APPROVED SEWER PIPES:**
- (1) CAST IRON SEWER PIPE
 - (2) VITRIFIED CLAY SEWER PIPE
 - (3) APPROVED PLASTIC PIPE AND FITTINGS (MIN. SDR 35 OR HEAVIER)
 - (NOTE: FROM A POINT AT LEAST 3 FEET OUTSIDE THE EDGE OF THE TRAILER TO SEWAGE SYSTEM.)

NOTE: D-2729 NOT APPROVED FOR ANY PART OF SYSTEM

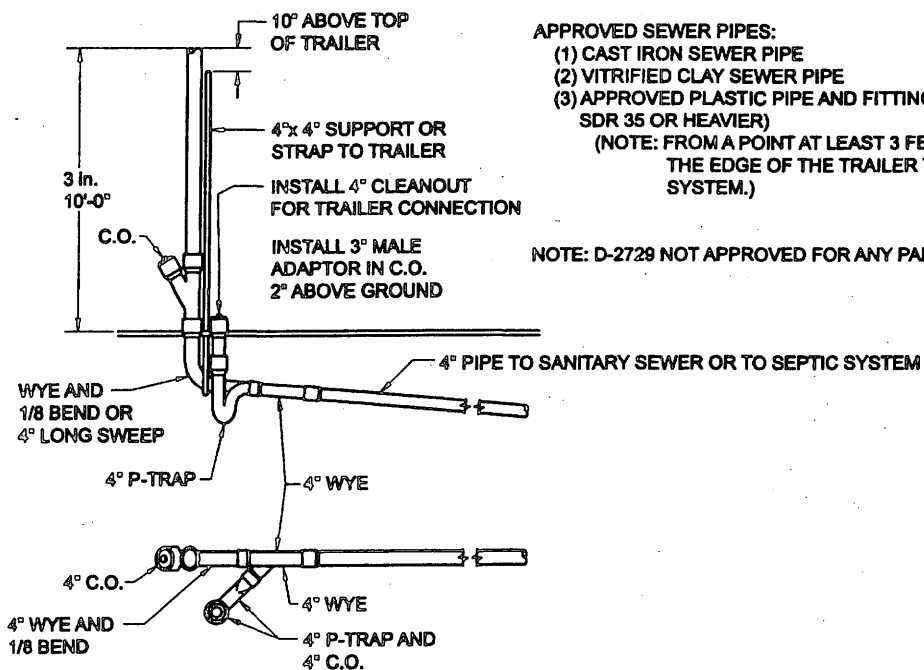

1004 INTERCEPTORS AND SEPARATORS

1004.1 When required

Interceptors or separators shall be provided for the proper handling of liquid wastes containing grease, oil, flammable waste, sand, solids or other ingredients harmful to the building drainage system, the public or private sewer or sewage treatment plant or processes except when, in the opinion of the Plumbing Official, they are not necessary.

1004.2 Size and Type

The size, type and location of each interceptor or separator shall be approved by the plumbing official.

1004.3 Type of Waste

No wastes other than those requiring treatment or separation shall be discharged into any interceptor or separator except where otherwise specifically permitted.

1004.4 Grease Traps/Grease Interceptors

An approved type grease trap/grease interceptor, complying with the provisions of this section and Appendix M of this code, shall be installed in the waste line leading from sinks, drains and other fixtures or equipment in establishments such as restaurants; cafes; lunch counters; cafeterias; bars and clubs; hotels; hospitals; sanitariums; factory, school or day care center kitchens; markets; or other establishments where grease may be introduced into the drainage or sewage system in quantities that can affect line stoppage or hinder sewage treatment or private sewage disposal, except when, in the opinion of the Plumbing Official, they are not necessary.

1004.5 Oil Separators

An oil separator shall be installed in the drainage system section of the system where, in the opinion of the plumbing official, a hazard exists or where oils or other flammables can be introduced or admitted into the drainage system by accident or otherwise.

1004.6 Sand Interceptors

Sand and similar interceptors for heavy solids shall have a water seal of not less than 2 inches (51 mm).

1004.7 Venting Interceptors

Interceptors shall be so designed that they will not become air bound if closed covers are used. Each interceptor shall be properly vented.

1004.8 Accessibility Of Interceptors

Each interceptor shall be so installed as to provide ready accessibility to the cover and means for servicing and maintaining the interceptor in working and operating condition. The use of ladders or the removal of bulky equipment in order to service interceptors shall constitute a violation of accessibility.

1004.9 Water Connection

If permitted by the Plumbing Official, water connection for cooling or operating an interceptor shall be such that backflow cannot occur.

1004.10 Special Occupancy Provisions

1004.10.1 Laundries.

1004.10.1.1 Interceptors. Commercial laundries shall be equipped with an interceptor having a removable wire basket or similar device that will prevent strings, rags, buttons, or other materials detrimental to the public sewerage system from passing into the drainage system.

1004.10.1.2 Intercepting Device. A basket or other device shall prevent passage into the drainage system of solids 1/2 inch (12.7 mm) or larger in size. The basket or device shall be removable for cleaning purposes.

1004.10.2 Bottling Plants. Bottling plants shall discharge their process wastes into an interceptor which will provide for the separation of broken glass or other solids, before discharging liquid wastes into the drainage system.

1004.10.3 Slaughter House Drains. Slaughtering room drains shall be equipped with separators which shall prevent the discharge into the drainage system of feathers, entrails and other materials likely to clog the drainage system.

1004.11 Food Service

1004.11.1 Commercial Food Grinders

Where commercial food-waste grinders are installed, the waste from those units shall discharge through a grease trap.

1004.11.2 Wash Racks

Every wash rack and/or floor or slab used for cleaning shall be adequately protected against storm or surface water and shall drain or discharge into an interceptor of an approved design for this use.

1004.12 Maintenance

1004.12.1 Grease Traps and Grease Interceptors.

Grease traps and grease interceptors shall be maintained in efficient operating condition by periodic removal of the accumulated grease. No such collected grease shall be introduced into any drainage piping, or public or private sewer.

1004.12.2 Interceptors and Separators in General.

Interceptors and separators of all types shall be maintained in efficient operating condition by periodic removal of accumulated material for which the interceptor or separator has been designed. No such collected material shall be introduced into any drainage piping, or public or private sewer.

1004.13 Special Type Separators

The plumbing official may require the submittal of drawings and other pertinent information.

CHAPTER 11 STORM DRAINAGE

1101 GENERAL

1101.1 Scope

The provisions of this chapter shall govern the materials, design, construction, and installation of storm drainage.

1101.2 Drainage Required

Roofs, paved areas, yards, courts and courtyards shall be drained into a storm sewer system.

1101.3 Prohibited Drainage

Storm water shall not be drained into sewers intended for sewage only.

1101.4 Expansion Joints

Expansion joints or sleeves shall be provided where warranted by temperature variations or physical conditions.

1101.5 Subsoil Drains

Where subsoil drains are placed under the cellar or basement floor or are used to surround the outer walls of a building, they shall be made of open-jointed or horizontally split or perforated clay tile, asbestos cement pipe, or plastic pipe meeting the requirements of Table 703, not less than 4-inch diameter. When the building is subject to backwater, the subsoil drain shall be protected by an accessibly located backwater valve. Subsoil drains may discharge into a properly trapped area drain or sump. Such sumps do not require vents.

1101.6 Building Subdrains

Building subdrains located below the public sewer level shall discharge into a sump or receiving tank, the contents of which shall be automatically lifted and discharged into the drainage system as required for building sumps.

1101.7 Pumping System

Pumping systems installed to remove contents of collecting sumps shall include the sump pump, pit, and discharge piping as defined below.

1. Sump Pump: An automatic water pump for the removal of drainage from a sump, pit, or low point in a residential, commercial, or industrial property shall be of a capacity and head appropriate to anticipated use requirements.
2. Sump Pit: Size shall be not less than 18-inch (457 mm) diameter and may be constructed of tile, steel, plastic, cast iron, concrete, or other material accepted by the plumbing official, topped by a removable cover adequate to support anticipated loads in area of use. The pump floor shall provide permanent support for the pump.
3. Electrical service outlets, when required, shall meet the requirements of NFPA 70 or local codes.

4. Discharge piping shall meet the requirements of 1103.1, 1103.2, 1103.3 or 1103.4 and shall include a gate valve and a full flow check valve. Size and fittings shall be the same size as, or larger than, pump discharge tapping.

1101.8 Backwater Devices

The installation of backwater devices as protection for fixtures subject to backflow shall be in accordance with requirements of this code.

1101.9 Tests

The interior leaders and downspouts system shall be tested in accordance with 311.5.

1102 DEFINITIONS

1102.1 The following definition has been deleted without substitution: COMBINED BUILDING SEWER.

1102.2 The following definitions have been moved to Chapter 2: AREA DRAIN, BUILDING STORM DRAIN, CONDUCTOR, LEADER, SANITARY SEWER.

1103 MATERIALS

1103.1 Inside Conductors Including Above Ground Storm Drains

Conductors placed within buildings or run in vent or pipe shafts shall be aluminum, cast iron, galvanized or black steel, galvanized ferrous alloys, brass, copper tubing of a weight not less than that of copper drainage tube Type DWV, copper pipe or schedule 40 plastic pipe.

1103.2 Building Storm Drains

All building storm drains shall be of materials required for building drains in Sections 703.3 and 703.4.

1103.3 Underground Building Storm Drains

Underground building storm drains, inside the building perimeter, shall be of cast iron soil pipe, ferrous-alloy piping, copper tube Type DWV, or Schedule 40 plastic piping.

1103.4 Building Storm Sewers

The building storm sewer shall be of cast iron soil pipe, vitrified-clay pipe, concrete pipe, or plastic pipe meeting the requirements of Table 703.

1104 SPECIFICATIONS

Pipe, tubing, and fittings for storm drainage systems shall conform to the standards listed in Table 703.

1106 CONDUCTORS AND CONNECTIONS

1106.2 Protection

Rain water conductors installed along alleyways, driveways, or other locations where they may be exposed to damage shall be protected.

1106.3 Separation of Storm Drainage from Sanitary Sewers

The sanitary sewer and storm drainage systems of a building shall be entirely separate.

1106.4 Floor Drains

Floor drains shall not be connected to a storm drain.

1107 ROOF DRAINS

1107.1 Material

Roof drains shall be of an approved corrosion resistant material with adequate strainer area and shall comply with the applicable standards in Table 303.

1107.2 Strainers

When roof drains are provided they shall have strainers extending not less than 4 inches (102 mm) above the surface of the roof immediately adjacent to the roof drain. Strainers shall have an available inlet area, above roof level, of not less than one and one-half times the area of the conductor or leader to which the drain is connected.

1107.3 Flat Decks

Roof drain strainers for use on sun decks, parking decks, and similar areas, normally serviced and maintained, may be of the flat surface type, level with the deck and shall have an available inlet area not less than two times the area of the conductor or leader to which the drain is connected.

1107.4 Roof Drain Flashings

The connection between roofs and roof drains which pass through the roof and into the interior of the building shall be made watertight by the use of proper flashing material.

1108 SIZE OF LEADERS AND STORM DRAINS

1108.1 Vertical Leaders

Vertical leaders shall be sized for the maximum projected roof area, according to Table 1108.1.

Table 1108.1
Size of Vertical Leaders

Size of Leader or Conductor ¹ (in)	Maximum Projected Roof Area (sq ft)
2	720
2 1/2	1300
3	2200
4	4600
5	8650
6	13,500
8	29,000

¹ 1 in = 25.4 mm, 1 ft² = 0.0929 m²

Note:

1. The equivalent diameter of square or rectangular leader may be taken as the diameter of that circle which may be inscribed within the cross-sectional area of the leader. See 1108.2.2.

1108.2 Building Storm Drains

1108.2.1 The size of the building storm drain or any of its horizontal branches having a slope of 1/2 inch or less per foot (41.6 mm/m) shall be based upon the maximum projected roof area to be handled according to Table 1108.2.

Table 1108.2
Size of Horizontal Storm Drains

Diameter of Drain (in)	Maximum Projected Roof Area for Drains of Various Slopes (sq ft)		
	1/8 In Slope	1/4 In Slope	1/2 In Slope
3	822	1,160	1,644
4	1,880	2,650	3,760
5	3,340	4,720	6,680
6	5,350	7,550	10,700
8	11,500	16,300	23,000
10	20,700	29,200	41,400
12	33,300	47,000	66,600
15	59,500	84,000	119,000

1 in = 25.4 mm

1 ft² = 0.0929 m²

1108.2.2 Tables 1108.1 and 1108.2 are based upon a rate of rainfall of 4 inches (102 mm) per hour. If in any state, city or other political subdivision, the maximum rate of rainfall is more or less than 4 inches (102 mm) per hour, then the figures for roof area shall be adjusted proportionately by dividing the figure by four and multiplying by the maximum rate of rainfall in inches (mm) per hour. See 1108.4.

1108.3 Vertical Walls

In sizing roof drains and storm drainage piping, one-half of the area of any vertical wall which diverts rain water to the roof shall be added to the projected roof area for inclusion in calculating the required size of vertical leaders and horizontal storm drainage piping.

1108.4 Maximum Rates of Rainfall

Primary roof drain systems shall be designed using Tables 1108.1 and 1108.2 adjusted in accordance with 1108.2.2 for the local rainfall for a 60 minute duration and a 100 year return period in Figure 1108.4. The plumbing official may approve local weather data on the maximum rate of rainfall when available.

1108.5 Parapet Wall Scupper Location

See the Standard Building Code for parapet wall roof drainage scupper and overflow scupper location requirements.

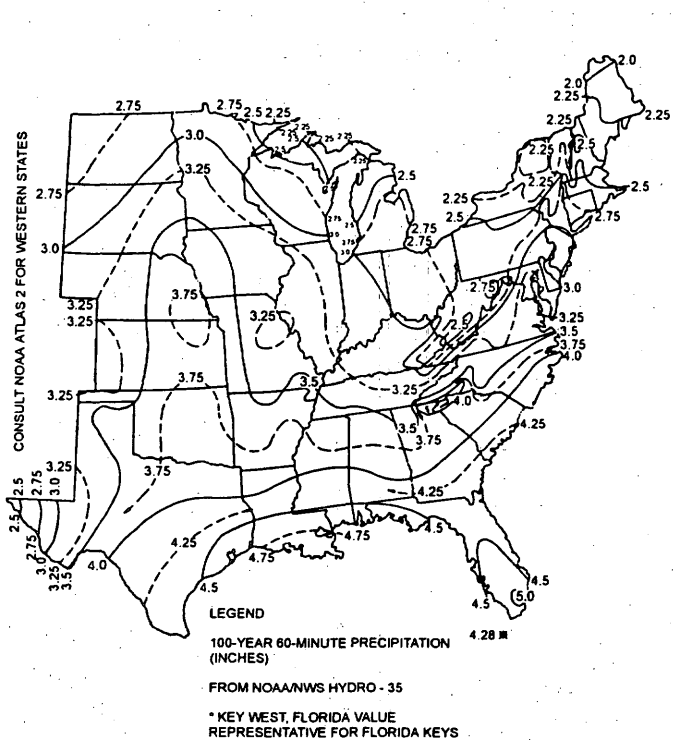

FIGURE 1108.4
RAINFALL RATES FOR PRIMARY ROOF DRAINS (IN/HR)

1109 SECONDARY (EMERGENCY) ROOF DRAINS

1109.1 Secondary Drainage Required

Secondary (emergency) roof drains or scuppers shall be provided where the roof perimeter construction extends above the roof in such a manner that water would be entrapped should the primary drains allow buildup for any reason.

1109.2 Separate Systems Required

Secondary roof drain systems shall have piping and point of discharge separate from the primary system. Discharge shall be above grade in a location which would normally be observed by the building occupants or maintenance personnel.

1109.3 Maximum Rainfall Rate for Secondary Drains

Secondary (emergency) roof drain systems or scuppers shall be sized based on the flow rate caused by the 100 year 15 minute precipitation as indicated in Figure 1109.3. The flow through the primary system shall not be considered when sizing the secondary roof drain system.

1111 VALUES FOR CONTINUOUS FLOW

Where there is a continuous or semicontinuous discharge into the building storm drain or building storm sewer, as from a pump, ejector, air conditioning plant, or similar device, each gallon per minute of such discharge shall be computed as being equivalent to 24 sq ft (2.23 m²) of roof area, based upon a 4-inch (102 mm) rainfall.

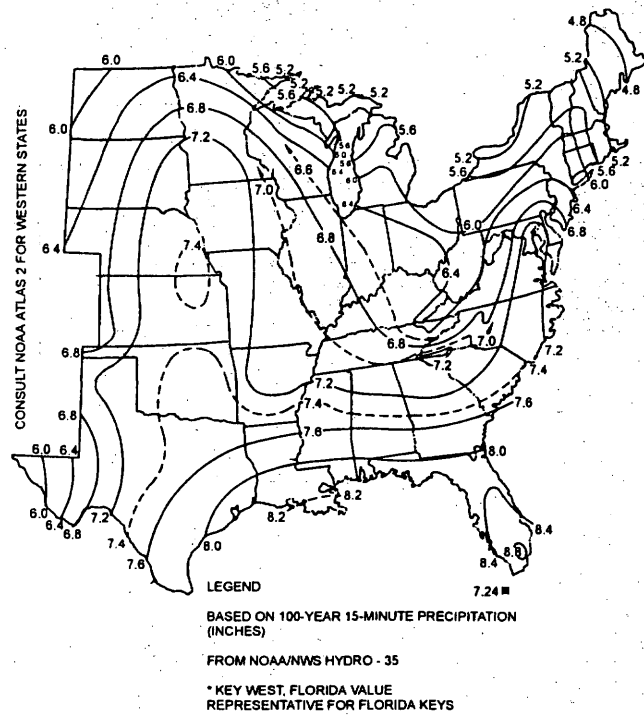

FIGURE 1109.3
RAINFALL RATES FOR SECONDARY ROOF DRAINS (IN/HR)

1113 APPENDIX REFERENCES

Additional provisions for storm drainage are found in Appendix A - Roof Drain Sizing Method. These provisions are applicable only where specifically included in the body of the code sections or in the adopting ordinance.

CHAPTER 12

ALTERNATE DESIGNED PLUMBING SYSTEMS

1201 GENERAL

Approval of alternate designed plumbing systems will be considered on an individual basis.

1202 REQUIREMENTS FOR APPROVAL

1202.1 Plans and Specifications

Plans and specifications for any proposed alternate designed plumbing system shall be submitted to the State Health Officer for review and approval prior to construction. Such plans and specifications shall be appropriately sealed and signed by a Louisiana Registered Professional Engineer registered in either civil or mechanical engineering.

1202.2 Responsibility of Professional Engineer

The Professional Engineer referenced in 1202.1 shall be responsible for:

1. certifying the system design,
2. inspecting the system during installation,
3. certifying that the installed system is in compliance with the design specifications,
4. supervising any test(s) performed on the system, and
5. certifying the results of any required testing.

1202.3 Owner's Notice

Any permits issued for an alternate designed plumbing system shall be issued only after the owner of the building has assured the State Health Officer in writing that he is aware of the third party notification requirements of 1204. In addition, any permits issued for work requiring a performance test shall be issued only after the owner of the building has assured the State Health Officer in writing that he is also aware of the testing requirements of 1203.

1203 TESTS

1203.1 General Testing Requirements

The State Health Officer and/or the local Plumbing Official may also require tests to be conducted prior to occupancy to assure that the proposed design is satisfactory and complies with the intent of this code. Such tests shall be made in accordance with approved standards, but in the absence of such standards, the State Health Officer and/or the local Plumbing Official shall specify the test procedure(s). In general, such tests shall indicate that all fixtures properly discharge when flushed simultaneously with not less than 1 inch (25.4mm) of water seal left in the trap after testing and that there is no evidence of sewer gas passing through the trap seal.

1203.2 Roughing-In. The roughing-in test shall be as provided for in other chapters of this code.

1203.3 Tests and Inspection of the Single Stack Discharge and Ventilating Pipe System

1203.3.1 Performance Test Required. In any building in which fixtures or appliances, other than those specifically provided for in Table L104.5A, are to be installed or in existing buildings in which the single stack system exists and additional fixtures are to be added, the plumbing official shall require and supervise a performance test as hereafter provided.

1203.3.2 Application and Restrictions. When required in new construction, the system shall successfully pass the test before the building is permitted to be occupied. In existing buildings where piping is added for additional fixtures or appliances, such new piping shall not be placed in service until the performance test is approved. Should the system fail to pass the test, the new construction shall be modified as the plumbing official may direct, or the system shall be reconstructed to meet the requirements of other chapters of this code, or the added fixtures and appliances shall be removed and all waste and vent pipes permanently closed so as to form no dead ends and all wall and other openings shall be put back in their original or finished condition.

EXCEPTION: Central washing facilities connected separately to the building drain or sewer in an installation that is otherwise constructed in accordance with other chapters of this code are exempt from the performance test.

1203.3.3 Performance Test. Every trap shall retain not less than 1 inch (25.4 mm) of seal when subjected to the appropriate discharge tests given below. These tests are designed to simulate the probable worst conditions in practice. Each test should be repeated three times, the trap being recharged before each test, and the maximum loss of seal in any one test, measured by a dip stick, shall be taken as the significant result. The number of fixtures to be discharged simultaneously when investigating the effect of the flow of water down the stack depends on the number of fixtures and on the frequency with which they are used. The number of fixtures to be discharged simultaneously is given in Table L104.11.

1203.3.4 Test for Self-Siphonage. To test for the effect of self-siphonage, the waste fixture shall be filled to overflowing level and discharged in the normal way. The seal remaining in the trap shall be measured when the discharge has finished. This test is most important for wash basins, but it is not applicable for water closets which shall be flushed in the normal manner.

1204 THIRD PARTY NOTIFICATION

After installation of any alternate designed plumbing system, the owner shall notify third parties of its existence by having a document recorded in the Clerk of Court's conveyance records in the parish in which such alternate designed plumbing system has been installed. The document so recorded shall reference a prior conveyance record (COB/folio) of the parcel of ground upon which the alternate designed plumbing system is located (*e.g.*, the conveyance recording a previous Act of Sale of the parcel of ground). The document will state that the plumbing of the building located on this particular parcel of ground contains an "alternate designed plumbing system" which cannot be modified in any manner by future owners/lessees without first obtaining an approval of such proposed modifications from the State Health Officer in accord with the requirements of Chapter 12 (Alternate Designed Plumbing Systems) of the Louisiana State Plumbing Code. Proof of recordation shall be provided to the State Health Officer and the local Plumbing Official prior to issuance of a building occupancy permit.

CHAPTER 13 SPECIAL PIPING AND STORAGE SYSTEMS

1301 HOSPITAL SYSTEMS

Provisions for hospital piping and storage systems are contained in Appendix G - Medical Facilities Plumbing Systems. Appendix G is a requirement of this code.

1302 MEDICAL GAS AND MEDICAL VACUUM SYSTEMS

All medical gas and medical vacuum systems shall be installed in compliance with all requirements of NFiPA 99.

CHAPTER 14 REFERENCE STANDARDS

1401 SCOPE

This chapter contains the designations, names and edition of standards referenced in this code listed alpha-numerically and the section numbers where they are referenced.

1402 REFERENCED STANDARDS

Products manufactured to those standards which are followed by the word "Listed" are required to be listed regardless of the standards' requirements for listing.

Standard Designation	Section	Standard Designation	Section
ANSI A40.5-1943, Threaded Cast Iron Pipe for Drainage, Vent and Waste Services	Table 603	ANSI/ASSE 1001-1990, Pipe-Applied Atmospheric-Type Vacuum Breakers	Table 606
ANSI A112.6.1M-1997, Supports for Off-the-Floor Plumbing Fixtures for Public Use	Table 303	ANSI/ASSE 1003-1995, Water Pressure Reducing Valves for Domestic Water Supply System	607.9.1, 607.9.7
ANSI A112.26.1M-1984, Water Hammer Arresters	607.8.2	ANSI/ASSE 1010-1998, Water Hammer Arresters Standard	607.8.2
ANSI A117.1-92, Accessible and Usable Buildings and Facilities	409.8.1	ANSI/ASSE 1011-1995, Vacuum Breakers, Hose Connection	Table 606
ANSI A119.2-1996, Parts I & II, Recreational Vehicles	B101, C101, C102	ANSI/ASSE 1012-1995, Backflow Preventers with Intermediate Atmospheric Vent	Table 606, 606.3.5
ANSI B16.5-1996 (R1998), Pipe Flanges and Flanged Fittings	Table 603	ANSI/ASSE 1025-1978, Diverters for Plumbing Faucets with Hose Spray, Anti-Siphon Type, Residential Applications	Table 303
ANSI B16.32-1992, Cast Copper Alloy Solder Joint Fittings for Solvent Drainage Systems	Table 703	ANSI/ASSE 1035-1995 Vacuum Breakers, Laboratory Faucet	Table 303, Table 606
ANSI B16.34-1996 (R1998), Valves-Flanged Threaded, and Welding End	Table 603	ANSI/ASSE 1037-1990 Pressurized Flushing Devices (Flushometers) for Plumbing Fixtures	Table 303
ANSI B16.43-1982, Wrought Copper and Copper Alloy Solder Joint Fittings for Solvent Drainage Systems	Table 703	ANSI/ASSE 1047-1995, Backflow Preventer, Reduced Pressure Detector Assembly	Table 606
ANSI B31.1-55, Code for Pressure Piping	612.4	ANSI/ASSE 1048-1995, Backflow Preventer, Double Check Detector Assembly	Table 606
ANSI Z4.1-1986 (R1995), Sanitation in Places of Employment, Minimum Requirement for	Table 407, Note 13	ANSI/ASSE 1052-1994, Backflow Preventer, Hose Connection	Table 606
ANSI Z21.10.1-1998, Gas Water Heaters, Volume I, Storage Water Heaters with Input Ratings of 75,000 Btu per Hour or Less	503.2	ANSI/ASSE 1056-1995, Vacuum Breaker, Back Siphonage, Pressure Type Assembly (Spill Resistant)	Table 606
ANSI Z21.10.3-1998, Gas Water Heaters Volume III, Storage, with Input Ratings Above 75,000 Btu per Hour, circulating and instantaneous	503.2	ANSI/AWS B2.2-1991, Brazing Procedure and Performance Qualification	309.4
ANSI Z21.22-1986 (R1990), Relief Valves and Automatic Gas Shutoff Devices for Hot Water Supply Systems	501.8.1, 507.1, 507.7	ANSI/AWWA C104/A21.4-1995, Cement-Mortar Lining for Ductile-Iron Pipe and Fittings for Water	Table 303
ANSI Z124.1-1995, Plastic Bathtub Units	Table 405	ANSI/AWWA C110/A 21.10-98, Ductile-Iron Fittings	Table 603
ANSI Z124.2-1995, Plastic Shower Receptors and Shower Stalls	Table 409.8	ANSI/AWWA C111/A21.11-1995, Rubber Gasket Joints for Ductile-Iron and Gray-Iron Pressure Pipe and Fittings	706.7
ANSI Z124.3-1995, Plastic Lavatories	Table 405	ANSI/AWWA C151/A 21.51-96, Ductile-Iron Water Pipe	Table 603
ANSI Z124.4-1996, Plastic Water Closet Bowls and Tanks	Table 405	ANSI/AWWA C203-97, Coal-Tar Protective Coatings and Linings for Steel Water Pipelines-Enamel and Tape-Hot-Applied	Table 303
ANSI Z124.5-1997, Standard for Plastic Toilet (Water Closet) Seats	Table 303	ANSI/AWWA C509-94, Resilient-Seated Gate Valves (including addendum 509a-95)	Table 611.4
ANSI Z124.6-1997, Standard for Plastic Sinks	Table 405	ANSI/AWWA C510-97, Backflow Preventers, Double Check Valve Assembly	Table 606
ANSI/ARI 1010-1994, Drinking Fountains and Self-Contained, Mechanically-Refrigerated Drinking-Water Coolers (mechanically refrigerated units)	409.2.1	ANSI/AWWA C511-97, Backflow Preventers, Reduced Pressure Principle Assembly	Table 606
		ANSI/AWWA C606-1997, Grooved and Shouldered Type Joints	Table 303
		ANSI/NSF 14-1998, Plastic Piping System Components and Related Materials	303.8.6, 308.8.1, Table 603
		ANSI/NSF 24-1988 (R1996), Plumbing System Components for Mobile Homes & Recreational Vehicles	Table 603
		ANSI/NSF 42-1999, Drinking Water Treatment Units-Aesthetic Effects	Table 303, 615.1
		ANSI/NSF 50-1996, Circulation System Components and Related Materials for Swimming Pools, Spas or Hot Tubs	409.10.1
		ANSI/NSF 53-1999, Drinking Water Treatment Units-Health Effects	Table 303, 615.1

ANSI/NSF 58-1997, Reverse Osmosis Drinking Water Treatment Units	Table 303. 615.2	ASME B 16.29-1994, Wrought Copper and Wrought Copper Alloy Solder Joint Drainage Fittings-DWV for Plumbing Drainage Waste and Vents	Table 703
ANSI/NSF 61-1999, Drinking Water System Components-Health Effects	303.6	ASSE 1002-1999, Performance Requirements for Water Closet Flush Tank Ball Cocks	Table 606
ANSI/NSPI 2-1999, Public Spas	Table 409.10	ASSE 1013-1993, Reduced Pressure Principle Backflow Preventers	606.3.5, Table 606
ANSI/NSPI 3-1999, Permanently Installed Residential Spas	Table 409.10	ASSE 1014-1990, Hand Held Showers	Table 303
ANSI/NSPI 6-1999, Residential Portable Spas	Table 409.10	ASSE 1015-1993, Double Check Backflow Prevention Assembly	Table 606
ASME Boiler and Pressure Vessel Code, Section IX, Welding and Brazing Qualifications, 1998 Edition	309.4	ASSE 1016-1996, Individual Thermostatic Pressure Balancing and Combination Control Valves for Bathing Facilities	Table 613
ASME A13.1-1996, Scheme for the Identification of Piping Systems	605	ASSE 1017-1999, Temperature Actuated Mixing Valves for Primary Domestic Use	Table 613
ASME A112.4.1-1993 (R1998), Water Heater Relief Valve Drain Tubes	Table 507	ASSE 1018-1986, Performance Requirements for Trap Seal Primer Valves - Water Supply Fed	614.4.1
ASME A112.1.2-1991 (R1998), Air Gaps in Plumbing Systems	409.2.1, 409.2.2, 606.1, Table 606, D103	ASSE 1019-1997, Wall Hydrants, Frost Proof Automatic Draining, Anti-Backflow Types	Table 303, Table 606
ASME A 112.14.1-1975 (R1998), Backwater Valves	704.7.2	ASSE 1020-1998, Pressure Vacuum Breaker Assembly (Outdoor Use)	Table 606
ASME A 112.18.1M-1996, Plumbing Fixture Fittings	Table 405	ASSE 1028-1980, Automatic Flow Controllers	Table 303
ASME A112.18.6 - 1999, Flexible Water Connectors	Table 405	ASSE 1029-1981, Water Supply Valves: Mixing Valves	Table 613
ASME A 112.19.1M-1994, Enameled Cast Iron Plumbing Fixtures	Table 405	ASSE 1032-1980, Dual Check Valve Type Backflow Preventers, for carbonated beverage dispensers-post mix type	Table 606
ASME A 112.19.2M-1998, Vitreous China Plumbing Fixtures	Table 405, 409.2.1	ASSE 1034-1981, Fixed Flow Restrictors	Table 303
ASME A 112.19.3M-1987 (R1996), Stainless Steel Plumbing Fixtures (Designed for Residential Use)	Table 405	ASSE 5000-1998, Backflow Prevention Assembly Tester	D108.1.1
ASME A 112.19.4M-1994, Steel Plumbing Fixtures, Porcelain Enameled Formed	Table 405	ASSE 5010-1998, Field Test Procedures for Backflow Preventer Assemblies	311.6, Table 606
ASME A 112.19.7M-1995, Whirlpool Bathtub Appliances	409.14.5	ASSE 5030-1998, Backflow Prevention Assembly Repairer	D108.1.2
ASME A 112.19.8M-1987 (R1996), Suction Fittings for Use in Swimming Pools, Wading Pools, Spas, Hot Tubs, and Whirlpool Bathtub Appliances	409.10.2, 409.14.6	ASTM A48-94ae1, Spec. for Gray Iron Castings	Table 703, 710.7
ASME A 112.19.9M-1991 (R1998), Non-vitreous Ceramic Plumbing Fixtures	Table 405	ASTM A 53-98, Spec. for Pipe, Steel, Black and Hot-Dipped, Zinc-Coated Welded and Seamless	Table 603
ASME A 112.19.5-1979 (R1998), Trim for Water-Closet Bowls, Tanks and Urinals	Table 405	ASTM A 74-98, Spec. for Cast Iron Soil Pipe and Fittings	Table 703, 303.7.6.1
ASME A 112.19.6-1995, Hydraulic Requirements for Water Closets & Urinals	Table 405	ASTM A 126-95e1, Spec. for Gray Iron Castings for Valves, Flanges, and Pipe Fittings	Table 603, Table 611.4
ASME A 112.21.1M-1991 (R1998), Floor Drains	Table 303	ASTM A 197/A 197M-98, Spec. for Cupola Malleable Iron	Table 603
ASME A 112.21.2M-1983, Roof Drains	Table 303	ASTM A 268A/ 268M-96, Spec. for Seamless and Welded Ferritic & Martensitic Stainless Steel Tubing for General Service	Table 603
ASME A 112.36.2M-1991 (R1998), Cleanouts	Table 303	ASTM A 377-95e1, Spec. for Ductile-Iron Pressure Pipe	Table 603
ASME B 1.20.1-1983 (R1992), Pipe Threads, General Purpose	308.2	ASTM A 653/ A 653M-98a, Spec. for Steel Sheet, Zinc-Coated (Galvanized) or Zinc-Iron Alloy-Coated (Galvannealed) by the Hot-Dip Process	Table 303
ASME B 16.15-1985 (R1994), Cast Bronze Threaded Fittings, Classes 125 and 250	Table 603	ASTM A 746-95, Spec. for Ductile Iron Gravity Sewer Pipe	Table 703
ASME B 16.18-1984 (R1992), Cast Copper Alloy Solder Joint Pressure Fittings	Table 603	ASTM A 865-97, Spec. for Threaded Couplings, Steel, Black and Zinc-Coated (Galvanized) Welded and Seamless, for Use in Steel Pipe Joints	Table 603
ASME B 16.22-1995, Wrought Copper and Copper Alloy Solder Joint Pressure Fittings for Copper Water Tube	Table 603	ASTM A 888-98e1, Spec. for Hubless Cast Iron Soil Pipe and Fittings for Sanitary and Storm Drain, Waste, and Vent Piping Applications	Table 703
ASME B 16.23-1992, Cast Copper Alloy Solder Joint Drainage Fittings-DWV for Plumbing Drainage Waste and Vents	Table 703		
ASME B 16.24-1991 (R1998), Cast Copper Alloy Pipe Flanges: Class 150, 300, 400, 600, 900, 1500, and 2500 and Flanged Fittings Class 150 and 300	Table 603		
ASME B 16.26-1988, Cast Copper Alloy Fittings for Flared Copper Tubes	Table 603		

ASTM B 32-96, Spec. for Solder Metal	Table 303	ASTM C1277-97, Standard Specification for Shielded Couplings Joining Hubless Cast Iron Soil Pipe and Fittings	Table 303
ASTM B 42-98, Spec. for Seamless Copper Pipe, Standard Sizes	Table 603		
ASTM B 43-98, Spec. for Seamless Red Brass Pipe, Standard Sizes	Table 603	ASTM D 395-98, Test Methods for Rubber Property-Compression Set. See 707.4	Table 303
ASTM B 75-97, Spec. for Seamless Copper Tube	Table 603	ASTM D 412-98a, Test Methods for Rubber Properties in Tension. See 707.4	Table 303
ASTM B 88-96, Spec. for Seamless Copper Water Tube	Table 603, 608.1.2, 611.2, F103	ASTM D 788-96, Spec. for Methacrylate Molding and Extrusion Compounds	Table 303
ASTM B 135-96, Spec. for Seamless Brass Tube	Table 603	ASTM D 789-98, Text Methods for Determination of Relative Viscosity, Melting Point, and Moisture Content of Polyamide (PA)	Table 303
ASTM B 152-97a, Spec. for Copper Sheet, Strip, Plate and Rolled Bar	Table 303	ASTM D 1457-88, Spec. PTFE Molding and Extrusion Materials	Table 303
ASTM B 248-98, Spec. for General Requirements for Wrought Copper and Copper-Alloy Plate, Sheet, Strip, and Rolled Bar	Table 303	ASTM D 1527-96a, Spec. for Acrylonitrile-Butadiene-Styrene(ABS) Plastic Pipe, Schedules 40 and 80	Table 603
ASTM B 251-97, Spec. for General Requirements for Wrought Seamless Copper and Copper-Alloy Tube. Square and rectangular tubing not applicable	Table 603	ASTM D 1785-96b, Spec. for Poly (Vinyl Chloride) (PVC) Plastic Pipe, Schedules 40, 80, and 120	Table 603
ASTM B 260-62T, Specification for Brazing Filler Metal	Table 303	ASTM D 1869-95 Spec. for Rubber Rings for Asbestos-Cement Pipe	Table 303
ASTM B 302-98, Spec. for Threadless Copper Pipe	Table 603	ASTM D 2104-96, Spec. for Polyethylene (PE) Plastic Pipe, Schedule 40	Table 603
ASTM B 306-96, Spec. for Copper Drainage Tube (DWV)	Table 703	ASTM D 2133-81, Spec. for Acetal Resin Injection Molding and Extrusion Materials	Table 303
ASTM B 447-97, Spec. for Welded Copper Tube	Table 603	ASTM D 2235-96a, Listed, Spec. for Solvent Cement for Acrylonitrile-Butadiene-Styrene (ABS) Plastic Pipe and Fittings	Table 303
ASTM B 543-96, Spec. for Welded Copper and Copper-Alloy Heat Exchanger Tube	Table 703	ASTM D 2239-96a, Spec. for Polyethylene (PE) Plastic Pipe (SIDR-PR) Based on Controlled Inside Diameter	Table 603
ASTM B 587-97, Spec. for Welded Brass Tube	Table 603	ASTM D 2241-96b, Spec. for Poly (Vinyl Chloride)(PVC) Pressure-Rated Pipe (SDR-Series). Listed	Table 603
ASTM B 641-93, Spec. for Seamless and Welded Copper Distribution Tube (Type D)	Table 603	ASTM D 2282-96a, Spec. for Acrylonitrile-Butadiene-Styrene (ABS) Plastic Pipe (SDR-PR)	Table 603
ASTM B 642-88e, Spec. for Welded Copper Alloy UNS NO. C21000 Water Tube	Table 603	ASTM D 2321-89, Practice for Underground Installation of Thermoplastic Pipe for Sewers and Other Gravity-Flow Applications, Installation	Table 303, Table 703
ASTM B 813-93, Spec. for Liquid and Paste Fluxes for Soldering Applications for Copper and Copper Tube	Table 303	ASTM D 2466-97, Specification for Poly (Vinyl Chloride) (PVC) Plastic Pipe Fittings Schedule 40	Table 603
ASTM B 828-98, Practice for Making Capillary Joints by Soldering of Copper and Copper Alloy Tube and Fittings	Table 303	ASTM D 2467-98a, Spec. for Socket-Type Poly(Vinyl Chloride)(PVC) Plastic Pipe Fittings, Schedule 80. Listed	Table 603
		ASTM D 2468-96, Spec. for Acrylonitrile-Butadiene-Styrene (ABS), Plastic Pipe Fittings, Schedule 40. Listed	Table 603
ASTM C 4-98, Spec. for Clay Drain Tile and Perforated Clay Drain Tile	Table 703	ASTM D 2564-96a, Listed, Spec. for Solvent Cements for Poly(Vinyl Chloride)(PVC) Plastic Piping Systems	Table 303
ASTM C 14-95, Spec. for Concrete Sewer, Storm Drain, and Culvert Pipe (<i>Approved for storm drain use only</i>)	Table 703	ASTM D 2657-97, Practice for Heat Joining of Polyolefin Pipe and Fittings	Table 303, 612.5.2
ASTM C 76-98a, Spec. for Reinforced Concrete Culvert, Storm Drain, and Sewer Pipe (<i>Approved for storm drain use only</i>)	Table 703	ASTM D 2661-97a, Spec. for Acrylonitrile Butadiene-Styrene (ABS) Plastic Drain, Waste and Vent Pipe and Fittings Listed	Table 703
ASTM C 361-98, Spec. for Reinforced Concrete Low-Head Pressure Pipe Metric (<i>Approved for storm drain use only</i>)	Table 703	ASTM D 2665-98, Spec. for Poly (Vinyl Chloride)(PVC) Plastic Drain, Waste, and Vent Pipe and Fittings	Table 703
ASTM C 412-94, Spec. for Concrete Drain Tile	Table 703	ASTM D 2672-96a, Spec. for Joints for IPS PVC Pipe Using Solvent Cement	Table 603
ASTM C 425-98, Spec. for Compression Joints for Vitrified Clay Pipe and Fittings	308.5, Table 703	ASTM D 2737-96a, Spec. for Polyethylene (PE) Plastic Tubing. Listed	Table 603
ASTM C 443-98, Spec. for Joints for Circular Concrete Sewer and Culvert Pipe, Using Rubber Gaskets	Table 303	ASTM D 2751-96a, Spec. for Acrylonitrile-Butadiene-Styrene (ABS) Sewer Pipe and Fittings	Table 703
ASTM C 444-95, Spec. for Perforated Concrete Pipe	Table 703		
ASTM C 564-97, Spec. for Rubber Gaskets for Cast Iron Soil Pipe and Fittings	Table 303, 706.4.2		
ASTM C478-96, Spec. for Precast Reinforced Concrete Manhole Sections	Table 703, 710.7		
ASTM C 700-98, Spec. for Vitrified Clay Pipe, Extra Strength, Standard Strength, and Perforated	Table 703		
ASTM C 1053-90, Spec. for Borosilicate Glass Pipe and Fittings for Drain, Waste, and Vent (DWV) Applications	Table 703		
ASTM C 1173-97, Spec. for Flexible Transition Couplings for Underground Piping Systems	Table 303		

ASTM D 2774-94, Standard Practice for Underground Installation of Thermoplastic Pressure Piping	Table 303	ASTM F 1380-95a, Spec. for Metal Insert Fittings for Polybutylene (PB) Tubing	Table 303
ASTM D 2846/D 2846M-97, Spec. for Chlorinated Poly(Vinyl Chloride)(CPVC) Plastic Hot-and Cold-Water Distribution Systems	Table 603	ASTM F 1488-98, Spec. for Coextruded Composite Pipe	Table 703
ASTM D 2855-96, Standard Practice for Making Solvent-Cemented Joints with Poly(Vinyl Chloride)(PVC) Plastic Pipe and Fittings	Table 303	ASTM F 1499-97, Spec. for Coextruded Composite Drain, Waste, and Vent Pipe (DWV)	Table 703
ASTM D 3034-98, Spec. for Type PSM Poly (Vinyl Chloride)(PVC) Sewer Pipe and Fittings	Table 703	CAN/CSA-B64.10-94, Manual for the Selection, Installation, Maintenance, and Field Testing of Backflow Prevention Devices	311.6, Table 606
ASTM D 3139-98, Spec. for Joints for Plastic Pressure Pipes Using Flexible Elastomeric Seals. See 308.8.2	Table 603	CAN/CSA B125-1993, Plumbing Fittings	606.3.7
ASTM D 3212-96a, Spec. for Joints for Drain and Sewer Plastic Pipes Using Flexible Elastomeric Seals	Table 703	CAN/CSA-B137.2-93, Listed, PVC Injection-Molded Gasketed Fittings for Pressure Applications	Table 603
ASTM D 4551-96 Poly (Vinyl Chloride) (PVC) Plastic Flexible Concealed Water-Containment Membrane	303.7.7.1, Table 409.8	CAN/CSA-B137.5-97, Listed, Cross-Linked Polyethylene (PEX) Tubing Systems for Pressure Applications	Table 603
ASTM F 402-93, Practice for Safe Handling of Solvent Cements, Primers, and Cleaners Used for Joining Thermoplastic Pipe and Fittings	Table 303	CAN/CSA-B181.1-96, ABS Drain, Waste, and Vent Pipe and Pipe Fittings	704.7.2
ASTM F 409-98, Spec. for Thermoplastic Accessible and Replaceable Plastic Tube and Tubular Fittings	Table 603	CAN/CSA-B181.2-96, PVC Drain, Waste, and Vent Pipe and Pipe Fittings	704.7.2
ASTM F 437-96a, Spec. for Threaded Chlorinated Poly (Vinyl Chloride) (CPVC) Plastic Pipe Fittings, Schedule 80. Listed	Table 603	CAN/CSA-B181.3-M86(R1992), Polyolefin Laboratory Drainage Systems	Table 703
ASTM F 439-98, Spec. for Socket-Type Chlorinated Poly (Vinyl Chloride) (CPVC) Plastic Pipe Fittings, Schedule 80. Listed	Table 603	CAN/CSA-B-182.4-97, Profile PVC Sewer Pipe and Fittings	Table 703
ASTM F 441/F 441M-97, Spec. for Chlorinated Poly (Vinyl Chloride) (CPVC) Plastic Pipe, Schedules 40 and 80. Listed	Table 603	CDA Copper Sovent Single Stack Plumbing System Design Handbook No. 402/0 (<i>For informational purposes only since is alternate designed plumbing governed under Chapter 12 requirements</i>)	L105.3
ASTM F 442/F 442M-97, Spec. for Chlorinated Poly (Vinyl Chloride) (CPVC) Plastic Pipe (SDR-PR)	Table 603	CDA Copper Tube Handbook (<i>For informational purposes only</i>)	Table F103C
ASTM F 493-97, Spec. for Solvent Cements for Chlorinated Poly(Vinyl Chloride)(PVC) Plastic Pipe and Fittings	Table 303	CISPI HS-74(R1986), Spec. for Cast Iron Soil Pipe and Fittings for Hub and Spigot Sanitary and Storm Drain, Waste and Vent Piping Applications	Table 703
ASTM F 628-97ae1, Spec. for Acrylonitrile-Butadiene-Styrene(ABS) Schedule 40 Plastic Drain, Waste, and Vent Pipe with a Cellular Core. Listed.	Table 703	CISPI HSN-85, Standard Spec. for Neoprene Rubber Gaskets for Hub and Spigot Cast Iron Soil Pipe and Fittings	Table 303
ASTM F 656-96a, Spec. for Primers for Use in Solvent Cement Joints of Poly(Vinyl Chloride) (PVC) Plastic Pipe and Fittings	Table 303	CISPI Std. 301-90, Std. Spec. for Hubless Cast Iron Soil Pipe and Fittings for Sanitary and Storm Drain, Waste, and Vent Piping Applications	Table 703
ASTM F 789-95a, Spec. for Type PS-46 and Type PS-115 Poly (Vinyl Chloride)(PVC) Plastic Gravity Flow Sewer Pipe and Fittings. See 704.1, 1101.4, 1103.3, 1103.4	Table 703	CISPI 310-90, Spec. for CISPI's Approved Coupling for use in connection with Hubless Cast Iron Soil Pipe and Fittings for Sanitary and Storm Drain, Waste, and Vent Piping Applications	Table 303, Table 703, 706.5.3
ASTM F 876-98, Spec. for Crosslinked Polyethylene (PEX) Tubing	Table 603	FMRC 1680-89, Couplings Used In Hubless Cast Iron Systems for Drain, Waste or Vent, Sewer, Rainwater or Storm Drain Systems Above and Below Ground, Industrial/Commercial and Residential	Table 303
ASTM F 877-98, Spec. for Crosslinked Polyethylene (PEX) Plastic Hot and Cold-Water Distribution Systems. Listed	Table 603	FS A-A-2956 (1995), Heater, Water, Electrical, Residential	503.1
ASTM F 891-98, Spec. for Coextruded Poly(Vinyl Chloride)(PVC) Plastic Pipe with a Cellular Core	Table 703	FS HH-C-536c(54), Plumbing Fixture Setting Compound	Table 405
ASTM F 1281-98a, Spec. for Crosslinked Polyethylene/Aluminum/Crosslinked Polyethylene (PEX-AL-PEX) Pressure Pipe	Table 603	FS QQ-L-156 (46), Caulking Lead	Table 405
ASTM F 1282-98a, Spec. for Polyethylene/Aluminum/Polyethylene (PE-AL-PE) Composite Pressure Pipe	Table 603	FS QQ-L-201F(2) (1965), Lead Sheet, [AMD 02 (1970)]	Table 303
ASTM F 1290-98a, Practice for Electrofusion Joining Polyolefin Pipe and Fittings	Table 303, 612.5.2	FS SS-P-381, Concrete Pipe Pressure Reinforced- Pretention Reinforcement Steel	Table 703

★	FS WW-N-351a(56), Nipples Pipe (Threaded)	Table 603	ASME	The American Society of Mechanical Engineers United Engineering Center 345 East 47th Street New York, New York 10017 Tel. (212) 705-8500 or ASME's New Jersey Service Center Tel. 1-800-843-2763 [1-800-THE-ASME]
	FS WW-P-325(44), Pipe, Bends, Traps, Caps, and Plugs; Lead (for Industrial Pressure, and Soil and Waste Applications)	Table 703		
★	FS WW-P-541 E/GEN(1), (1980), Plumbing Fixtures (General Specifications), [AMD 01 (1990)]	Table 405		
★	IAPMO PS 49-1993, Backflow Prevention Requirements for Fixture Fittings with Hose Connected Singular Moveable Outlets	606.3.7		
	MSS SP-72 (1992), Ball Valves with Flanged or Butt-Welding Ends for General Service	Table 611.4	ASSE	American Society of Sanitary Engineering 28901 Clemens Road, Suite 100 Westlake, Ohio 44145 Tel. (440) 835-3040
	MSS SP-80 (1997), Bronze Gate, Globe, Angle and Check Valves	Table 611.4		
	MSS SP-110 (1996), Ball Valves Threaded, Socket- Welding, Solder Joint, Grooved, and Flared Ends	Table 611.4	ASTM	American Society for Testing and Materials 100 Barr Harbor Drive West Conshohocken, Pennsylvania 19428-2959 Tel. (610) 832-9585 Fax (610) 832-9555
	NFiPA 70-99 National Electrical Code	717.9.2, 1101.7		
	NFiPA 99-99, Medical Gas Systems	1302, G105		
	PDI-G101-1996, Testing and Rating Procedure for Grease Interceptors with Appendix of Sizing and Installation Data	M105.1	AWS	American Welding Society 550 N.W. LeJeune Road Miami, Florida 33126 Tel. (305) 443-9353 Tel. (800) 443-9353 Fax (305) 443-7559
	PDI-WH201-1992, Water Hammer Arresters	607.8.2		
	SBCCI Standard Building Code, 1994 Edition	201.3, 202, 303.8.3.1, 304.2.2 306.1, 407.4, 609.5, 616, L104.8 1108.5	AWWA	American Water Works Association 6666 West Quincy Avenue Denver, Colorado 80235-3098 Tel. (303) 794-7711 Tel. 1-800-926-7337
	SBCCI Standard Fire Prevention Code, 1994 Edition	201.3		
	SBCCI Standard Gas Code, 1994 Edition	201.3, 616		
	SBCCI Standard Mechanical Code, 1994 Edition	201.3, 616		
★	UL 174-1996, Water Heaters, Household Electric Storage Tank	503.1	CDA	Copper Development Association, Inc. 260 Madison Ave. New York, New York 10016
	UL 1795-1999, Hydromassage Bathtubs	409.14.4	CISPI	Cast Iron Soil Pipe Institute 5959 Shallowford Road, Suite 419 Chattanooga, Tennessee 37421

1403 ORGANIZATIONS

The following is a list by name and address of those agencies, associations, institutes and others that are referred to in this code by name, initials or symbols. Further there are those listed, for convenience, whose technical and other services are made available to the Standard Plumbing Code.

AGA	American Gas Association, Inc. 1515 Wilson Blvd. Arlington, Virginia 22209		
ANSI	American National Standards Institute, Inc. 11 West 42nd Street, 13th Floor New York, New York 10036 Tel. (212) 642-4900		
ARI	Air-Conditioning & Refrigeration Institute 4301 N. Fairfax Drive, Suite 425 Arlington, Virginia 22203 Tel. (703) 524-8800 Fax (703) 528-3816		
		CAN/CSA	Canadian Standards Association 178 Rexdale Boulevard Rexdale (Toronto), Ontario Canada M9W 1R3 Tel. (416) 747-4000 Tel. 1-800-463-6727
		FMRC	Factory Mutual Research Corporation Standards-Laboratories Department 1151 Boston-Providence Turnpike, P.O. Box 9102 Norwood, Massachusetts 02062-9102
		FS	Federal Specifications General Services Administration Federal Supply Service Specification Section 470 E. L'Enfant Plaza SW, Suite 8100 Washington, D.C. 20407 Tel. (202) 619-8925 Fax (202) 619-8978

MSS
Manufacturers Standardization Society
of the Valve and Fittings Industry, Inc.
127 Park Street, N.E.
Vienna, Virginia 22180-4602
Tel. (703) 281-6613
Fax (703) 281-6671

NFiPA
National Fire Protection Association
One Batterymarch Park
Quincy, Massachusetts 02269-9101

NSF
NSF International
3475 Plymouth Road
P.O. Box 130140
Ann Arbor, Michigan 48113-0140

NSPI
National Spa and Pool Institute
2111 Eisenhower Avenue
Alexandria, Virginia 22314
Tel. (703) 838-0083

PDI
Plumbing and Drainage Institute
45 Bristol Drive, Suite 101
South Easton, Massachusetts 02375
Tel. (800) 589-8956
Tel. (508) 230-3516
Fax (508) 230-3529

PPFA
Plastic Pipe & Fittings Association
800 Roosevelt Road, Building C, Suite 20
Glen Ellyn, Illinois 60137-5833
Tel. (630) 858-6540
Fax (630) 790-3095

PPI
Plastic Pipe Institute
A Division of the Plastics Industry, Inc.
1801 "K" Street, NW
Washington, DC 20006-1301
Tel. (202) 974-5318
(Note: "more PE pipe focus")

UL
Underwriters Laboratories, Inc.**
333 Pfingsten Road
Northbrook, Illinois 60062-2096
Tel. (847) 272-8800
Fax (847) 272-8129

** Standards available from:

Global Engineering Documents
15 Inverness Way East
Englewood, Colorado 80112-5776
Tel. (303) 397-7956
Tel. (800) 854-7179
Fax (303) 397-2740

APPENDIX A ROOF DRAIN SIZING METHOD

(APPENDIX A IS FOR INFORMATIONAL PURPOSES ONLY)

A101 Sizing Example

The following example gives one method of sizing the primary drain system and sizing the scuppers in the parapet walls. This method converts the roof area to an equivalent roof area for a 4-inch rate of rainfall so that Table 1108.1 and Table 1108.2 can be used as printed. The method described in 1108.2.2 converts Table 1108.1 and Table 1108.2 to tables for the rate of rainfall specified for the area.

A101.1 Problem: Given the roof plan in Figure A101.1 and the site location in Birmingham, Alabama, size the primary roof drain system and size the scuppers, denoting the required head of water above the scupper for the structural engineer.

Note: For the purposes of this appendix the following metric conversions are applicable:

- 1 in = 25.4 mm
- 1 ft = 305 mm
- 1 ft² = 0.0929 m²

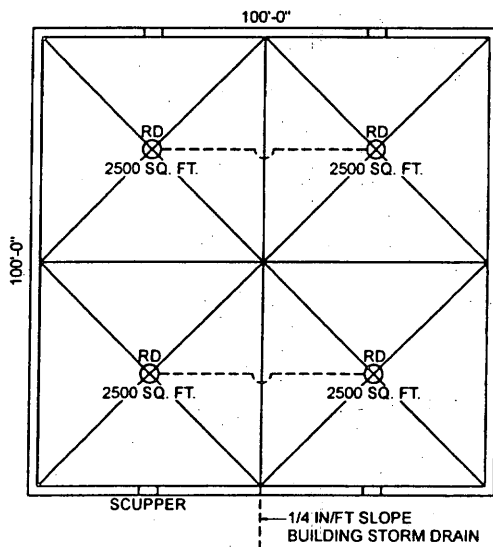

Figure A101.1
Example Roof Plan

A 101.2 Solution:

Step 1. From Figure 1108.4 the 100 year 60 minute precipitation is 3.75 inches per hour.

Step 2. Each vertical drain must carry 2,500 sq ft of roof area at 3.75 inches per hour of rainfall. To convert to an area for a 4 inch per hour rainfall to enter Table 1108.1 do this:

$$2,500 \div 4 \times 3.75 = 2,344 \text{ sq ft.}$$

Enter Table 1108.1 until you find a diameter pipe that will carry 2,344 sq ft. A minimum 4-inch vertical drain is required.

Step 3. Horizontal Drain

2,500 sq ft.

To convert to an area for use in Table 1108.2 do this:

$$2,500 \div 4 \times 3.75 = 2,344 \text{ sq ft}$$

Enter Table 1108.2 until you find a diameter pipe that will carry 2,344 sq ft. A minimum 4-inch diameter pipe with a 1/4 inch per foot slope will carry 2,650 sq ft. A minimum 4-inch diameter drain on a 1/4 inch per foot slope is required.

Step 4. Horizontal Drain

5,000 sq ft.

To convert to an area for use in Table 1108.2 do this:

$$5,000 \div 4 \times 3.75 = 4,688 \text{ sq ft.}$$

Enter Table 1108.2 until you find a diameter pipe that will carry 4,688 sq ft. A 5-inch diameter pipe with a 1/4 inch per foot slope will carry 4,720 sq ft. A minimum 5-inch diameter drain on a 1/4 inch per foot slope is required.

Step 5. Horizontal Drain

10,000 sq ft.

To convert to an area for use in Table 1108.2 do this:

$$10,000 \div 4 \times 3.75 = 9,375 \text{ sq ft.}$$

Enter Table 1108.2 until you find a diameter pipe that will carry 9,375 sq ft. An 8-inch diameter pipe on 1/4 inch per foot slope will carry 16,300 sq ft but a 6-inch will carry only 7,550 sq ft, therefore, use an 8-inch diameter drain on a 1/4 inch per foot slope.

Step 6. From Figure 1109.3 the rate caused by a 100 year 15 minute precipitation is 7.2 inches per hour. The scuppers must be sized to carry the flow caused by a rain fall rate of 7.2 inches per hour.

Step 7. Each scupper is draining 2,500 sq ft of roof area. To convert this roof area to an area for use with Table A101.2 do this:

$$2,500 \div 4 \times 7.2 = 9,375 \text{ sq ft} = 4,500 \text{ sq ft.}$$

Enter Table A101.2 to find a length and head that will carry 4,500 sq ft or more. From Table A101.2 a 12-inch wide weir with a 4-inch head carries 6,460 sq ft. Use 12-inch wide x 5-inch high scuppers at four locations. A height of 5 inches is needed to assure an open area above the 4-inch head.

Step 8. Notify the structural engineer that the design of the roof structure must account for a height of water to the scupper entrance elevation plus 4 inches for the required head to cause design flow.

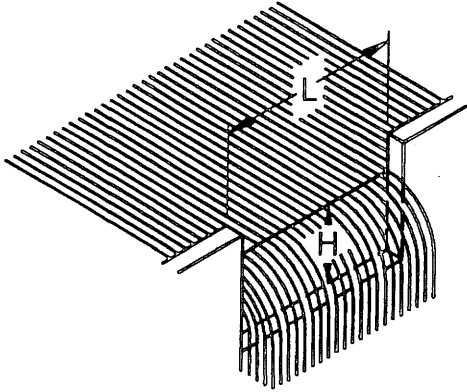

Figure A101.2

Table A101.2
 Scupper Sizing Table
 Roof Area (sq ft)

Head (H) Inches	Length (L) of Weir (Inches)						
	4	6	8	12	16	20	24
1	273	418	562	851	1,139	1,427	1,715
2	734	1,141	1,549	2,365	3,180	3,996	4,813
3	1,274	2,023	2,772	4,270	5,768	7,267	8,766
4	1,845	2,999	4,152	6,460	8,766	11,073	13,381
6	2,966	5,087	7,204	11,442	15,680	19,918	24,160

Note:
 Table based on rainfall of 4 inches per hour.

APPENDIX B TRAVEL TRAILERS AND TRAVEL TRAILER PARKS

(APPENDIX B IS A REQUIREMENT OF THIS CODE)

B101 GENERAL

With the exception of Section B112, the requirements set forth in this appendix shall apply specifically to all new travel trailer parks, and to additions to existing parks as herein defined, and are to provide minimum standards for sanitation and plumbing installation within these parks, for the accommodations, use and parking of travel trailers. Plumbing installations in travel trailers shall be installed in accordance with ANSI A119.2, Part I.

B102 DEFINITIONS

Definitions contained in Chapter 2 shall also apply to this appendix except where the following special definitions shall apply.

AIR LOCK - a condition where air is trapped in a drain or drain hose and retards or stops the flow of liquid waste or sewage.

CENTER - of a mobile/manufactured home or travel trailer is the longitudinal center line located midway between the right and the left side.

COMBINATION COMPARTMENT - a shower stall with or without a door which provides for or includes a water closet. It is sized for occupancy of only one person.

DEPARTMENT HAVING JURISDICTION - the administrative authority or other law enforcement agency having jurisdiction over this regulation.

DEPENDENT TRAVEL TRAILER - a trailer coach not equipped with a water closet.

DRAIN HOSE - the approved type hose, flexible and easily detachable, used for connecting the drain outlet to a sewer inlet connection.

DRAIN OUTLET - the lowest end of the main drain to which the terminal end of the drain hose is connected.

INDEPENDENT MOBILE/MANUFACTURED HOME OR TRAVEL TRAILER - one equipped with a water closet and a bath or shower.

INLET COUPLING - the terminal end of the water system to which the water service connection is made. It may be a swivel fitting or threaded pipe end.

INTERMEDIATE WASTE HOLDING TANK - (travel trailers only) an enclosed tank for the temporary retention of water-borne waste.

LENGTH - the distance measured from the tip of the hitch to the part farthest to the rear of a mobile/manufactured home or travel trailer.

MOBILE/MANUFACTURED HOME OR TRAVEL TRAILER PARK - any lot, tract, parcel or plot of land upon which more than one travel trailer and/or mobile/manufactured homes are parked for the temporary or permanent use of a person or persons for living, working or congregating.

PARK DRAINAGE SYSTEM - the entire system of drainage piping used to convey sewage or other wastes from the mobile/manufactured home or travel trailer drain outlet connection, at its connection to the mobile/manufactured home or travel trailer site, to a public sewer or private sewage disposal system.

PARK WATER SUPPLY SYSTEM - all of the water supply piping within the park, extending from the main public supply or other source of supply to, but not including, the mobile/manufactured home or travel trailer service system, and including branch service lines, fixture devices, service buildings and appurtenances thereto.

SERVICE BUILDING - a building housing toilet and bathing facilities for men and women, with laundry facilities.

SEWER LATERAL - that portion of the park drainage system extending to a mobile/manufactured home or travel trailer site.

TRAILER TRAP - a device, fitting or assembly of fittings installed in the sewer lateral for a travel trailer or mobile/manufactured home which is used to prevent the circulation of air between the park drainage system and the drainage system of the individual travel trailer or mobile/manufactured home.

TRAVEL TRAILER - a vehicular, portable structure built on a chassis, designed to be used as a temporary dwelling for travel, recreational and vacation uses, permanently identified "Travel Trailer" by the manufacturer on the trailer and when factory equipped for the road, having a body width not exceeding 8 ft (2438 mm) and being of any length provided its gross weight does not exceed 4,500 lb (2041 kg), or being of any weight provided its overall length does not exceed 29 ft (8839 mm).

TRAVEL TRAILER SANITARY SERVICE STATION - a sewage inlet with cover, surrounded by a concrete apron sloped inward to the drain, and watering facilities to permit periodic washdown of the immediately adjacent area, to be used as a disposal point for the contents of intermediate waste holding tanks of travel trailers.

B103 GENERAL REGULATIONS

B103.1 Governing Provisions

The general provisions of the Louisiana State Plumbing Code shall govern the installation of plumbing systems in travel trailer parks, except where special conditions or construction are specifically defined in this appendix.

B103.2 Travel Trailer Sites

B103.2.1 Travel trailers shall not hereafter be parked in any travel trailer park unless there are provided plumbing and sanitation facilities installed and maintained in conformity with these regulations. Every travel trailer shall provide a gastight and watertight connection for sewage disposal which shall be connected to an underground sewage collection system discharging into a public or private disposal system.

B103.2.2 No dependent travel trailer shall be parked at any time in a space designed and designated for an independent travel trailer unless public toilet and bath facilities are available within 200 ft (61 m) of the dependent travel trailer.

B103.3 Travel Trailer Sanitary Service Station

At least one travel trailer sanitary service station shall be provided in all travel trailer parks that accept any travel trailers having an intermediate waste holding tank.

B104 PLANS AND SPECIFICATIONS

The owner or operator of every travel trailer park, before providing areas of space for the use and accommodation of travel trailers, shall make application for a permit (where such permit is required by state, parish, city or other local laws or ordinances) or, regardless of whether or not an actual permit is required, shall file two sets of plans and specifications with the department(s) having jurisdiction for their review and approval. The plans and specifications shall be in detail as follows:

1. A scaled plot plan of the park, indicating the spaces, area or portion of the park for the parking of travel trailers.
2. Size, location and specification of the park drainage system.
3. Size, location and specification of water supply lines.
4. Size, location and layout of service building. (See B105.)
5. Size, location, specification and layout of the fire protection system, if applicable.
6. A scaled layout of typical trailer sites.
7. Applications/submittals shall bear the approval of the local enforcement agencies as to compliance with city or parish plumbing, zoning and health ordinances.
8. Plumbing required by this article shall comply with all city, parish and state plumbing and health ordinances and regulations.
9. The issuance of a permit (or an approval of a submittal) shall not constitute approval of any

violation of this article or of any city or parish ordinance or regulation.

10. An approved set of plans and specifications and a copy of the permit (or written approval of a submittal) shall be kept on the park premises until the final inspection has been made.

B105 SERVICE BUILDINGS

B105.1 Minimum Facilities

B105.1.1 Each travel trailer park shall have at least one service building to provide necessary sanitation and laundry facilities. Those parks serving independent travel trailers need provide only minimum facilities.

B105.1.2 The service building shall be of permanent construction with an interior finish of moisture resistant material which will stand frequent washing and cleaning and the building shall be well-lighted and ventilated at all times.

B105.2 Independent Trailers

The service buildings of only independent travel trailer parks shall have a minimum of one water closet, one lavatory, one shower or bathtub for females and one water closet, one lavatory, and one shower or bathtub for males. In addition, at least one laundry tray and one drinking fountain located in a common area shall be provided.

B105.3 Dependent Trailers

The service buildings in parks that also accommodate dependent travel trailers shall have a minimum of two water closets, one lavatory, one shower or bathtub for females, and one water closet, one lavatory, one urinal, and one shower or bathtub for males. In addition, at least one laundry tray and one drinking fountain located in a common area shall be provided. The above facilities are for a maximum of ten dependent travel trailers. For every ten additional dependent travel trailers (or any fraction thereof) the following additional fixtures shall be provided: One laundry tray, one shower or bathtub for each sex, and one water closet for females. Also, one additional water closet for males shall be provided for every 15 additional dependent travel trailers (or any fraction thereof).

B105.4 Water Supply for Fixtures

B105.4.1 Hot and cold water shall be provided for all fixtures except water closets.

B105.4.2 Each water closet, tub and shower shall be in separate compartments, with self-closing doors on all water closet compartments. The shower stall shall be a minimum of 3 x 3 ft (914 x 914 mm) in area, with a dressing compartment with a stool or bench for females.

B105.4.3 The laundry trays and washing machines shall be contained in a room separate from the toilet rooms.

B105.5 Floor Drains

A minimum 2-inch floor drain shall be installed in each toilet room and laundry room (see 409.4.1.1.).

B106 MATERIALS

Unless otherwise provided for in this appendix, all piping fixtures or devices used in the installation of drainage and water supply systems for travel trailer parks, or parts thereof, shall conform to the quality and weights of materials required by the Louisiana State Plumbing Code.

B107 GENERAL REGULATIONS

Unless otherwise provided for in this appendix, all plumbing fixtures, piping drains, appurtenances and appliances designed and used in a park drainage, water supply system and service connections shall be installed in conformance with the Louisiana State Plumbing Code.

B108 PARK DRAINAGE SYSTEM

B108.1 The main sewer and sewer laterals shall be installed in a separate trench not less than 5 ft (1524 mm) from the park water service or distribution system. (See 608.3 and 608.4)

B108.2 The minimum size of pipe in any travel trailer park drainage system shall be 4 inches.

B108.3 Each travel trailer shall be considered as six fixture units in determining discharge requirements in the design of park drainage and sewage disposal systems.

B108.4 Minimum grade for sewers shall be so designed that the flow will have a mean velocity of 2 ft per second (0.6096 m/s) when the pipe is flowing half full.

B108.5 The discharge of a park drainage system shall be connected to a public sewer. Where a public sewer is not available, an approved individual or community sewage disposal system shall be installed, of a type that is acceptable and approved by the administrative authority or other law enforcement agency having jurisdiction over this regulation. [See Chapter XIII (Sewage Disposal), State of Louisiana Sanitary Code]

B108.6 Manholes and/or cleanouts shall be provided as required in Chapter 7 of the Louisiana State Plumbing Code. Manholes and/or cleanouts shall be accessible and brought to grade.

B108.7 The main sewer shall be provided with a minimum 4-inch vent, not more than 5 ft (1524 mm) downstream from its upper trap. Long mains shall be provided with additional relief vents at intervals of not more than 200 ft (61 m) thereafter. These relief vents shall be a minimum of 4 inches and shall be securely supported and extended a minimum of 10 ft (3048 mm) above the ground.

B108.8 Branch lines or sewer laterals to individual travel trailers shall be not less than 4-inch diameter.

B108.9 Sewer inlets shall be 4-inch diameter and extend above grade 3 to 6 inches (76 to 152 mm). Each inlet shall be provided with a gas-tight seal when connected to a trailer and have a gas-tight seal plug for use when not in service.

B108.10 Each trailer site shall be provided with a trailer trap. Sewer laterals over 30 ft (9144 mm) from the main park drainage sewer shall be properly vented and provided with a cleanout brought to grade.

B108.11 To provide the shortest possible drain connection between the travel trailer outlet and drain inlet, all drain inlets shall terminate with reference to the site location of the travel trailer.

B108.12 Drain connection shall slope continuously downward and form no traps. All pipe joints and connections shall be installed and maintained gastight and watertight.

B108.13 No sewage, waste water, or any other effluent shall be allowed to be deposited on the surface of the ground.

B108.14 Upon completion and before covering, the park drainage system shall be subjected to a static water test. The water test shall be applied to the drainage system either in its entirety or in sections. If applied to the entire system, all openings in the piping shall be tightly closed, except the highest opening, and the system shall be filled with water to point of overflow. If the system is tested in sections, each opening shall be tightly plugged except the highest opening of the section under test, and each section shall be filled with water, but no section shall be tested with less than a 10 ft head of water (30 kPa). In testing successive sections, at least the upper 10 ft (3048 mm) of the next preceding section shall be tested, so that no joint or pipe in the system shall have been submitted to a test of less than 10 ft head of water (30 kPa). The water shall be kept in the system, or in the portion under test, for at least 15 minutes before inspection starts; the system shall then be tight at all points.

B109 WATER DISTRIBUTION SYSTEM

B109.1 General

Every travel trailer site shall be provided with an individual branch service line delivering safe, pure, and potable water. The outlet of the branch service line shall terminate on the left side of the site of the travel trailer.

B109.2 Minimum Size

Water service lines to each trailer site shall be sized to provide a minimum 8 gpm (0.505 L/s) at the point of connection with the trailer distribution system. All water service lines shall be a minimum of $\frac{3}{4}$ inch.

B109.3 Backflow and Service Shutoff

B109.3.1 A minimum of a double check valve assembly backflow preventer shall be installed on the branch service line to each independent trailer at, or near, the trailer service connection. Backflow preventive devices shall be of an approved type certified by a recognized testing agency as to compliance and performance outlined herein. Valves shall be designed and maintained to close driptight at a reduced pressure of not less than 1 nor more than 5 psi (6.9 to 34.5 kPa). Valves must be identified with the manufacturer's name and model number.

B109.3.2 A separate service shutoff valve shall be installed in each branch service line on the supply of the backflow protective device.

B109.4 Service Connections

The service connection shall be not less than 1/2-inch diameter; no rigid pipe may be used. Flexible metal tubing is permitted. Fittings at either end shall be of a quick disconnect type not requiring any special tools or knowledge to install or remove.

B110 TRAVEL TRAILER CONNECTIONS

B110.1 Responsibility

When it is evident that there exists, or may exist, a violation of these rules, the owner, operator, lessee, person in charge of the park, or any other person causing a violation shall cause it to be corrected immediately or disconnect the service connection and travel trailer drain connection from the respective park branch service line and sewer lateral.

B110.2 Drain Connections

Travel trailer drain connections shall be of approved semi-rigid or flexible reinforced hose having smooth interior surfaces of not less than 3 inches inside diameter. Drain connections shall be equipped with a standard quick disconnect screw or clamp type fitting, not less in size than the outlet. Drain connections shall be gastight and no longer than necessary to make the connection between the travel trailer outlet and the trap inlet on the site.

B111 MAINTENANCE

All devices or safeguards required by this appendix shall be maintained in good working order by the owner, operator, or lessee of the travel trailer park or his designated agent.

B112 INDIVIDUAL TRAVEL TRAILERS

Individual travel trailers located within previously constructed travel trailer parks shall be provided with a trailer trap in accord with 1003.5.

TRAILER TRAP AND VENT

APPROVED MATERIALS FOR TRAP AND VENT

- (1) CAST IRON PIPE AND FITTINGS.
- (2) ABS OR PVC PLASTIC PIPE AND FITTINGS SCH. 40
(NOTE: DO NOT MIX ABS AND PVC PIPE AND/OR FITTINGS.)

APPROVED SEWER PIPES:

- (1) CAST IRON SEWER PIPE
- (2) VITRIFIED CLAY SEWER PIPE
- (3) APPROVED PLASTIC PIPE AND FITTINGS (MIN. SDR 35 OR HEAVIER)
(NOTE: FROM A POINT AT LEAST 3 FEET OUTSIDE THE EDGE OF THE TRAILER TO SEWAGE SYSTEM.)

NOTE: D-2729 NOT APPROVED FOR ANY PART OF SYSTEM

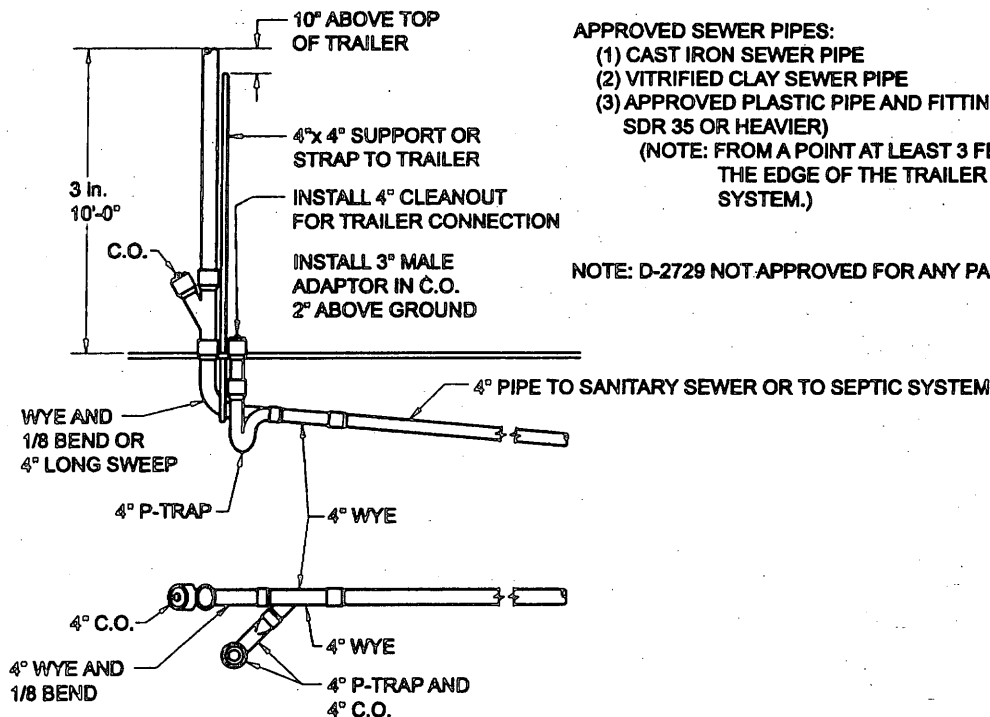

APPENDIX C MOBILE/MANUFACTURED HOMES AND MOBILE/MANUFACTURED HOME PARKS

(APPENDIX C IS A REQUIREMENT OF THIS CODE)

C101 PURPOSE, APPLICATION AND SCOPE

With the exception of Section C112, the requirements set forth in this appendix shall apply specifically to all new mobile/manufactured home parks, and to additions to existing parks as herein defined, and are to provide minimum standards for sanitation and plumbing installation within these parks, for the accommodation, use and parking of mobile/manufactured homes. Plumbing installations in mobile/manufactured homes shall be installed in accordance with ANSI A119.2, Part II.

C102 DEFINITIONS

Definitions contained in Chapter 2 and in Section B102 of Appendix B shall also apply to this appendix, except where the following special definition shall apply:

MOBILE/MANUFACTURED HOME - a vehicular, portable structure built on a chassis and designed to be used as a dwelling without a permanent foundation when connected to indicated utilities per ANSI A119.2.

C103 GENERAL REGULATIONS

C103.1 The general provisions of the Louisiana State Plumbing Code shall govern the installation of plumbing systems in mobile/manufactured home parks, except where special conditions or construction are specifically defined in this appendix.

C103.2 Mobile/manufactured homes shall not hereafter be parked in any mobile/manufactured home park unless plumbing and sanitation facilities have been installed and maintained in conformity with these regulations. Every mobile/manufactured home shall provide a gastight and watertight connection for sewage disposal which shall be connected to an underground sewage collection system discharging into a public or private disposal system.

C104 PLANS AND SPECIFICATIONS

The owner or operator of every mobile/manufactured home park, or the plumbing contractor employed by him before providing areas of space for the use and accommodation of independent mobile/manufactured homes, shall make application for a permit (where such permit is required by state, parish, city or other local laws or ordinances) or regardless of whether or not an actual permit is required, shall file two sets of plans and specifications with the department(s) having jurisdiction for their review and approval. The plans and specifications shall be in detail as follows:

1. A scaled plot plan of the park, indicating the spaces, area or portion of the park for the parking of mobile/manufactured homes.
2. Size, location and specification of park drainage system.
3. Size, location and specification of water supply lines.
4. Size, location and layout of service building. (See C110.)
5. Size, location, specification and layout of the fire protection system, if applicable.
6. A scaled layout of typical mobile/manufactured home sites.
7. Applications/submittals shall bear the approval of the local enforcement agencies as to compliance with city or parish plumbing, zoning and health ordinances.
8. Plumbing required by this appendix shall comply with all city, parish and state plumbing and health ordinances and regulations.
9. The issuance of a permit (or an approval of a submittal) shall not constitute approval of any violation of this appendix or violation of any city or parish ordinance or regulation.
10. An approved set of plans and specifications and a copy of the permit (or written approval of a submittal) shall be kept on the park premises until the final inspection has been made.

C105 MATERIALS

Unless otherwise provided for in this appendix, all piping fixtures or devices used in the installation of drainage and water supply systems for mobile/manufactured home parks, or parts thereof, shall conform to the quality and weights of materials required by the Louisiana State Plumbing Code.

C106 GENERAL REGULATIONS

Unless otherwise provided for in this appendix, all plumbing fixtures, piping, drains, appurtenances and appliances designed and used in a park drainage, water supply system and service connections shall be installed in conformance with the Louisiana State Plumbing Code.

C107 PARK DRAINAGE SYSTEM

C107.1 Minimum System

C107.1.1 The main sewer and sewer laterals shall be installed in a separate trench not less than 5 ft (1524 mm) from the park water service or distribution system. (See 608.3 and 608.4)

C107.1.2 The minimum size of pipe in any mobile/manufactured home park drainage system shall be 4 inches.

C107.1.3 Each mobile/manufactured home shall be considered as 15 fixture units in determining discharge requirements in the design of park drainage and sewage disposal systems.

C107.1.4 Minimum grade for sewers shall be so designed that the flow will have a mean velocity of 2 ft per second (0.6096 m/s) when the pipe is flowing half full.

C107.2 Discharge

The discharge of a park drainage system shall be connected to a public sewer. Where a public sewer is not available, an approved individual or community sewage disposal system shall be installed, of a type that is acceptable and approved by the plumbing official or other law enforcement agency having jurisdiction over this regulation. [See Chapter XIII (Sewage Disposal), State of Louisiana Sanitary Code]

C107.3 Manholes and Cleanouts

Manholes and/or cleanouts shall be provided as required in Chapter 7 of the Louisiana State Plumbing Code. Manholes and/or cleanouts shall be accessible and brought to grade.

C107.4 Inlets

Sewer inlets shall be 4-inch diameter and extend above grade 3 to 6 inches (76 to 152 mm). Each inlet shall be provided with a gastight seal when connected to a mobile/manufactured home and have a gastight seal plug for use when not in service.

C107.5 Unit Site Requirements

C107.5.1 Each mobile/manufactured home site shall be provided with a trailer trap. Sewer laterals over 30 ft (9144 mm) from the main park drainage sewer shall be properly vented and provided with a cleanout brought to grade.

C107.5.2 To provide the shortest possible drain connection between the mobile/manufactured home outlet and drain inlet, all drain inlets shall terminate in the rear one-third of the mobile/manufactured home as placed on the site.

C107.5.3 Drain connections shall slope continuously downward and form no traps. All pipe joints and connections shall be installed and maintained gastight and watertight.

C107.5.4 No sewage, waste water, or any other effluent shall be allowed to be deposited on the surface of the ground.

C107.6 Testing The System

Upon completion and before covering, the park drainage system shall be subjected to a static water test and inspected by the plumbing inspection department. The water test shall be applied to the drainage system either in its entirety or in sections. If applied to the entire system, all openings in the piping shall be tightly closed, except the highest opening, and the system shall be filled with water to point of overflow. If the system is tested in sections, each opening shall be tightly plugged except the highest opening of the section under test,

and each section shall be filled with water, but no section shall be tested with less than a 10 ft head of water (30 kPa). In testing successive sections, at least the upper 10 ft (3048 mm) of the next preceding section shall be tested so that no joint or pipe in the system shall have been submitted to a test of less than a 10 ft head of water (30 kPa). The water shall be kept in the system, or in the portion under test, for at least 15 minutes before inspection starts; the system shall then be tight at all points.

C108 WATER SUPPLY SYSTEM

C108.1 Every mobile/manufactured home site shall be provided with an individual branch service line delivering safe, pure and potable water. The outlet of the branch service line shall terminate on the left side of the site of the mobile/manufactured home.

C108.2 Water service lines to each mobile/manufactured home site shall be sized to provide a minimum of 17 gpm (1.1 L/s) at the point of connection with the mobile/manufactured home distribution system. The minimum size of branch service line to each site shall be 3/4 inch.

C108.4 A separate service shutoff valve shall be installed in each branch line.

C108.5 The service connection shall be not less than 1/2-inch diameter; no rigid pipe may be used. Flexible metal tubing is permitted. Fittings at either end shall be of a quick disconnect type not requiring any special tools or knowledge to install or remove.

C108.6 The water supply system shall be designed to provide a minimum of 150 gallons (568 L) per day for each mobile/manufactured home, plus such additional volume as may be required for fire protection of the park, service buildings and other community facilities.

C109 MOBILE/MANUFACTURED HOME CONNECTIONS

C109.1 When it is evident that there exists, or may exist, a violation of these rules, the owner, operator, lessee, person in charge of the park or any other person causing a violation shall cause it to be corrected immediately or disconnect the service connections and mobile/manufactured home drain connection from the respective park branch service line and sewer lateral.

C109.2 Mobile/manufactured home drain connections shall be of approved semi-rigid pipe having smooth interior surfaces of not less than 3-inch inside diameter. Drain connections shall be equipped with a standard quick disconnect screw, clamp type fitting or solvent welder, not less in size than the outlet. Drain connections shall be gastight and no longer than necessary to make the connection between the mobile/manufactured home outlet and the inlet on the site.

C110 SERVICE BUILDINGS

Each mobile/manufactured home park serving travel trailers shall have at least one service building to provide minimum sanitation and laundry facilities in accord with B105.

C111 MAINTENANCE

All devices or safeguards required by this appendix shall be maintained in good working order by the owner, operator, or lessee of the mobile/manufactured home park or his designated agent.

**C112 INDIVIDUAL MOBILE/
MANUFACTURED HOMES**

Individual mobile/manufactured homes located within previously constructed mobile/manufactured home parks shall be provided with a trailer trap in accord with 1003.5.

TRAILER TRAP AND VENT

APPROVED MATERIALS FOR TRAP AND VENT

- (1) CAST IRON PIPE AND FITTINGS.
- (2) ABS OR PVC PLASTIC PIPE AND FITTINGS SCH. 40
- (NOTE: DO NOT MIX ABS AND PVC PIPE AND/OR FITTINGS.)

APPROVED SEWER PIPES:

- (1) CAST IRON SEWER PIPE
- (2) VITRIFIED CLAY SEWER PIPE
- (3) APPROVED PLASTIC PIPE AND FITTINGS (MIN. SDR 35 OR HEAVIER)
- (NOTE: FROM A POINT AT LEAST 3 FEET OUTSIDE THE EDGE OF THE TRAILER TO SEWAGE SYSTEM.)

NOTE: D-2729 NOT APPROVED FOR ANY PART OF SYSTEM

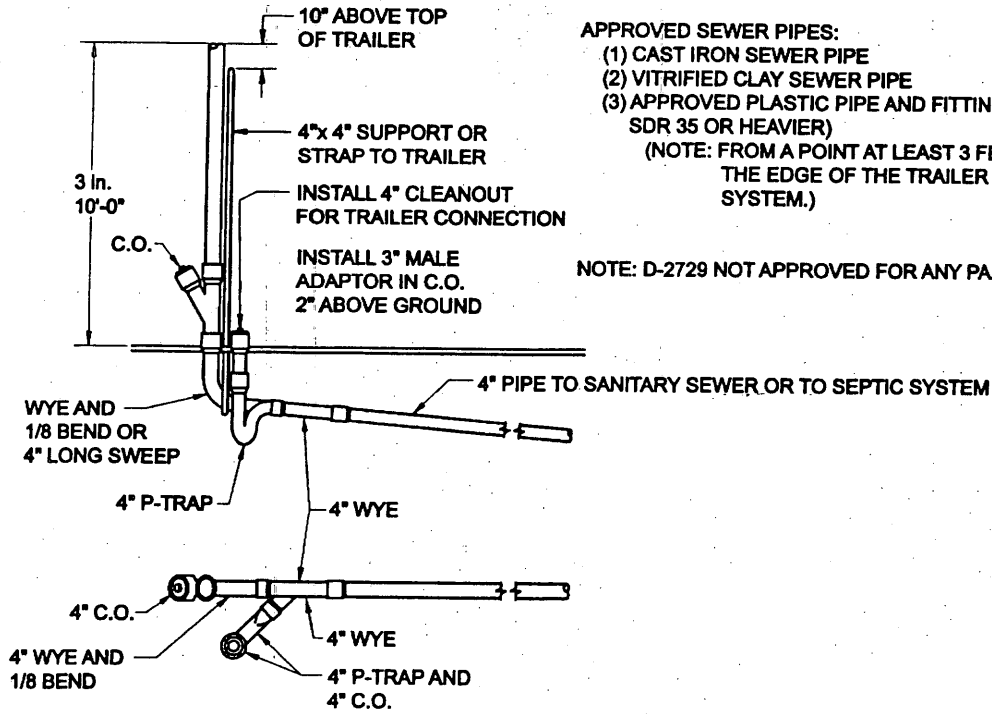

APPENDIX D CROSS CONNECTION CONTROL

(APPENDIX D IS A REQUIREMENT OF THIS CODE)

D101 The purpose of this Appendix is to provide for the protection of the public from the possibility of contamination or pollution by isolating such contaminants or pollutants which could backflow or back-siphon into a potable water supply; to promote the elimination or control of existing cross-connections, actual or potential, between potable water supplies and non-potable systems/sources; and to promote the maintenance of a continuing program of cross-connection control in the State of Louisiana.

D102 DEFINITIONS Definitions contained in Chapter 2 shall also apply to this appendix except where the following special definitions shall apply:

AIR GAP (WATER DISTRIBUTION) - in a water supply system, the unobstructed vertical distance through the free atmosphere between the lowest opening from any pipe or faucet supplying water to a tank, plumbing fixture, or other device and the flood-level rim of the receptacle.

ATMOSPHERIC VACUUM BREAKER - a device which prevents back-siphonage by creating an atmospheric vent when there is either a negative pressure or sub-atmospheric pressure in a water system.

BACKFLOW - the flow of water or other liquids, mixtures, or substances into the distribution pipes of a potable water supply from any source other than its intended source. (See Back-Pressure Backflow and Back-Siphonage Backflow.)

BACK-PRESSURE BACKFLOW - a condition which occurs when the downstream pressure is higher than the supply pressure causing a reversal of the normal direction of flow.

BACK-PRESSURE BACKFLOW PREVENTER - a device to prevent backflow due to a general condition in which the pressure in the system becomes greater than the supply pressure, the system being above atmospheric pressure. (See also Double Check Valve Assembly, Double Check Valve with Intermediate Atmospheric Vent, and Reduced Pressure Principle Backflow Preventer).

BACKFLOW PREVENTER - a device to prevent backflow. As there are two conditions of backflow, the device should be identified by the conditions which it is designed to prevent. (See Back-Pressure Backflow Preventer, Reduced Pressure Principle Backflow Preventer, Back-Siphonage Backflow Preventer).

BACK-SIPHONAGE BACKFLOW - a reversal of the normal direction of flow in the pipeline due to a negative

pressure (vacuum) being created in the supply line with the backflow source subject to atmospheric pressure.

BACK-SIPHONAGE BACKFLOW PREVENTER, GENERAL - a device or combination of devices for preventing back-siphonage backflow in a water supply line.

BAROMETRIC LOOP - a fabricated piping arrangement rising at least 35 feet at its topmost point above the highest fixture it supplies. It is utilized in water supply systems to protect against back-siphonage.

BY-PASS - any system of piping or other arrangement whereby the water may be diverted around any part or portion of a water supply or treatment facility including, but not limited to, around an installed backflow preventer.

COMMERCIAL DISHWASHER - a mechanical dishwasher that is used in other than domestic applications.

CONTAINMENT - a method of backflow prevention which requires a backflow prevention device or method on the water service pipe to isolate the customer from the water main.

CONTAMINATION - the introduction into water of microorganisms, chemicals, toxic substances, wastes or wastewater that makes the water unfit for its intended use.

CROSS CONNECTION - any connection or arrangement by means of which contaminants of any kind can be caused to enter the potable water supply system.

DEGREE OF HAZARD - the term is derived from an evaluation of the potential risk to public health and the adverse effect of the hazard upon the potable water.

DOUBLE CHECK VALVE ASSEMBLY - an assembly of two (2) independently operating spring loaded check valves with tightly closing shut off valves on each side of the check valves, plus properly located test cocks for the testing of each check valve.

DOUBLE CHECK VALVE WITH INTERMEDIATE ATMOSPHERIC VENT - a device having two (2) spring loaded check valves separated by an atmospheric vent chamber.

DUAL CHECK VALVE - two (2) spring loaded, independently operating check valves without tightly closing shut-off valves and test cocks. Generally employed immediately down stream of the water meter. Not an approved backflow prevention device.

FIXTURE ISOLATION - a method of backflow prevention in which a backflow preventer is located to correct a cross-connection at an in-plant location rather than at a water service pipe.

HOSE BIBB VACUUM BREAKER - a device which is permanently attached to a hose bibb and which acts as an atmospheric vacuum breaker.

MASTER METER - a meter serving multiple residential dwelling units. Individual units may or may not be sub-metered.

POTABLE WATER - water having bacteriological, physical, radiological and chemical qualities that make it safe and suitable for human drinking, cooking and washing uses.

POTABLE WATER SUPPLY - a publicly owned or privately owned water supply system which purveys potable water.

PRESSURE VACUUM BREAKER - a device containing one or two independently operated spring loaded check valves and an independently operated spring loaded air inlet valve located on the discharge side of the check or checks. Device includes tightly closing shut-off valves on each side of the check valves and properly located test cocks for the testing of the check valve(s).

PUBLIC WATER SYSTEM - a particular type of water supply system intended to provide potable water to the public having at least fifteen service connections or regularly serving an average of at least twenty-five individuals daily at least sixty days out of the year.

REDUCED PRESSURE PRINCIPLE BACKFLOW PREVENTER - an assembly consisting of two (2) independently operating approved check valves with an automatically operating differential relief valve located between the two (2) check valves, tightly closing shut-off valves on each side of the check valves plus properly located test cocks for the testing of the check valves and relief valves.

WATER SERVICE PIPE (or SERVICE CONNECTION) - the pipe from the water main and/or water meter, water supply system or other approved source of water supply, to the building or structure served.

WATER SUPPLIER - a person who owns or operates a water supply system including, but not limited to, a person who owns or operates a public water system.

WATER SUPPLY SYSTEM - the system of pipes or other constructed conveyances, structures and facilities through which water is obtained, treated to make it potable (if necessary) and then distributed (with or without charge) for human drinking, cooking, washing or other use.

D103 AIR GAPS The provision of air gaps shall be required for backflow prevention in any and all cases where such a measure is the most practical that can be employed. The "minimum required air gap (water distribution)" shall be in accord with ASME A 112.1.2.¹

Note:

1. For informational purposes only, ASME A 112.1.2 generally requires a minimum required air gap equal to two times the effective opening (or 3 times the effective opening if affected by a nearby wall). Compliance shall be strictly determined by the provisions contained within the standard itself.

D104.1 CONTAINMENT PRACTICES. Backflow prevention methods or devices shall be utilized as directed by the Plumbing Official to isolate specific water supply system customers from the water supply system's mains when such action is deemed necessary to protect the water supply system against potential contamination caused by backflow of water from that part of the water system owned and maintained by the customer (*e.g.*, the piping downstream of the water meter, if provided).

D104.2 As a minimum, the following types of devices or methods shall be installed and maintained by water supply system customers immediately downstream of the water meter (if provided) or on the water service pipe prior to any branch line or connections serving the listed customer types and categories:

Table D104¹

Air Gap	
1.	Fire Protection/Sprinkler System utilizing non-potable water as an alternative or primary source of water
Reduced Pressure Principle Backflow Preventer	
1.	Hospitals, Out-Patient Surgical Facilities, Renal Dialysis Facilities, Veterinary Clinics
2.	Funeral Homes, Mortuaries
3.	Car Wash Systems
4.	Sewage Facilities
5.	Chemical or Petroleum Processing Plants
6.	Animal/Poultry Feedlots or Brooding Facilities
7.	Meat Processing Plants
8.	Metal Plating Plants
9.	Food Processing Plants, Beverage Processing Plants
10.	Fire Protection/Sprinkler Systems using antifreeze in such system
11.	Marinas/Docks
12.	Radiator Shops
13.	Commercial Pesticide/Herbicide Applicators
14.	Photo/X-ray/Film Processing Laboratories
Double Check Valve Assembly	
1.	Fire Protection/Sprinkler Systems
2.	Multiple Residential Dwelling Units served by a master meter.
3.	Multistoried Office/Commercial Buildings (over 3 floors)
4.	Jails, Prisons, and Other Places of Detention or Incarceration

Note:

1. Other Containment Practices - Table D104 is not inclusive of all potential contamination sources which may need containment protection. For potential contamination sources not listed in this table, backflow prevention methods or devices shall be utilized as directed by the Plumbing Official [or by the water supplier for those devices which may be associated with the water supplier's own water supply system located on public property or otherwise under the complete control of the water supplier (e.g., water meter and the piping upstream of the water meter, if provided)].

D105.1 FIXTURE ISOLATION PRACTICES Water supply system customers shall provide and maintain backflow prevention methods or devices as directed by the Plumbing Official within that part of the water system owned and maintained by the customer (e.g., the piping downstream of the water meter, if provided, or downstream from any containment device) to protect the on-site users of the water system against potential contamination due to backflow.

D105.2 As a minimum, the following types of devices or methods shall be employed as appropriate for the following points of usage:

Table D 105^{1, 2}

Air Gap	
1.	Cooling Towers
2.	Chemical Tanks
3.	Commercial Dishwashers in commercial establishments
4.	Ornamental Fountains
5.	Swimming Pools, Spas, Hot Tubs
6.	Baptismal Fonts
7.	Animal Watering Troughs
8.	Agricultural Chemical Mixing Tanks
9.	Water Hauling Tanks
Reduced Pressure Principle Backflow Preventers	
1.	Commercial Boilers
2.	Air Conditioning, Chilled Water Systems
3.	Air Conditioning, Condenser Water Systems
4.	Pot-type Chemical Feeders
5.	Lawn Sprinklers with Fertilizer Injection
6.	Photo/X-ray/Film Processing Equipment
Double Check Valve Assembly	
1.	Food Processing Steam Kettles
2.	Individual Travel Trailer Sites
Atmospheric or Pressure Type Vacuum Breakers	
1.	Laboratory and/or Medical Aspirators
2.	Flushing Rim Bedpan Washers
3.	Garbage Can Washers
4.	Laboratory or Other Sinks with threaded or serrated nozzles
5.	Flushometer Operated Fixtures
6.	Commercial Washing Machines
7.	Lawn Sprinklers
8.	Hose Bibbs
9.	Commercial Dishwashers in commercial establishments

Notes:

1. See Tables G104.6 and G104.7 for fixture isolation practices in hospital plumbing systems.
2. Other Fixture Isolation Practices - Table D105 is not inclusive of all potential contamination sources which may need fixture isolation protection. For potential contamination sources not listed in this table, backflow prevention methods or devices shall be utilized as directed by the Plumbing Official.

D106 RESPONSIBILITY OF WATER SUPPLIERS

Water suppliers shall be responsible to insure the protection of the water supply system from potential contamination from certain of their customers through containment practices as prescribed by this Chapter or as otherwise directed by the State Health Officer.

D107 BYPASSES

D107.1 All bypasses shall have the same level of backflow protection as the main water supply line.

D108 MAINTENANCE/FIELD TESTING

D108.1 Types of Backflow Preventers to be Field Tested

D108.1.1 To ensure that installed backflow preventers provide continuing backflow protection, the following types of backflow preventers shall be checked and field tested in accordance with the frequency established in

D108.2 by a Backflow Prevention Assembly Tester who meets ASSE 5000 Professional Qualification Standard, or other individuals holding a testing certificate from a nationally recognized backflow certification organization approved by the Plumbing Official [or found acceptable to the water supplier for those devices which may be associated with the water supplier's own water supply system located on public property or otherwise under the complete control of the water supplier (*e.g.*, water meter and the piping upstream of the water meter, if provided)]:

- (a) double check valve assemblies;
- (b) reduced pressure principle backflow preventers;
- (c) pressure type vacuum breakers;
- (d) air gaps on high hazard applications; and
- (e) as otherwise specified by the Plumbing Official (or by the water supplier for those backflow preventers located on public property or otherwise under the complete control of the water supplier (*e.g.*, water meter and piping upstream of the water meter, if provided)).

It is recommended that other types of backflow prevention devices be visually checked periodically.

D108.1.2 Any backflow preventer in D108.1.1 which is found defective shall be repaired by a duly authorized water supply protection specialist licensed by the Louisiana State Plumbing Board pursuant to LSA - R.S. 37:1361 *et seq* and its implementing regulations (LAC 46:LV.101 *et seq*) or, for those backflow preventers located on public property or otherwise under the complete control of the water supplier (*e.g.*, water meter and the piping upstream of the water meter, if provided), by a Backflow Prevention Assembly Repairer who meets ASSE 5030 Professional Qualification Standard or other individuals found acceptable to the water supplier.

D108.2 Frequency of Field Testing

The backflow prevention devices specified in D108.1.1 shall be field tested:

- (a) upon installation;
- (b) when cleaned, repaired, or overhauled;
- (c) when relocated;
- (d) annually; and
- (e) as required by the Plumbing Official (or by the water supplier for those backflow preventers located on public property or otherwise under the complete control of the water supplier (*e.g.*, water meter and piping upstream of the water meter, if provided)).

D108.3 Owner Responsibilities

D108.3.1 It shall be the duty of the owner of the backflow preventer to see that these tests are made in a timely manner in accord with the frequency of field testing specified in D108.2.

D108.3.2 The owner shall notify the Plumbing Official and/or water supplier in advance when the tests are to be undertaken so that the Plumbing Official and/or water supplier may witness the tests if so desired.

D108.3.3 All tests, repairs, overhauls or replacements shall be at the expense of the owner of the backflow preventer.

D108.3.4 All records of such tests, repairs, overhauls or replacements shall be kept by the owner of the backflow preventer for at least 5 years and, upon request, shall be made available to the Plumbing Official, water supplier, and/or the State Health Officer.

APPENDIX E
PRIVATE SEWAGE DISPOSAL

(APPENDIX E IS A REQUIREMENT OF THIS CODE)

E101 General

Refer to Chapter XIII (Sewage Disposal) of the State of Louisiana Sanitary Code for applicable sewage disposal regulations.



APPENDIX F SIZING OF WATER PIPING SYSTEM

(APPENDIX F IS FOR INFORMATIONAL PURPOSES ONLY)

F101 GENERAL

F101.1 Scope

F101.1.1 This appendix outlines a procedure for sizing a water piping system. This design procedure is based on the minimum static pressure available from the supply source, the head charges in the system due to friction and elevation, and the rates of flow necessary for operation of various fixtures.

F101.1.2 Because of the variable conditions encountered in hydraulic design, it is impractical to specify definite and detailed rules for sizing of the water piping system. Accordingly, other sizing or design methods conforming to good engineering practice standards are acceptable alternates to that presented herein.

F102 INFORMATION REQUIRED

F102.1 Preliminary

Obtain the necessary information regarding the minimum daily static service pressure in the area where the building is to be located. If the building supply is to be metered, obtain information regarding friction loss relative to the rate of flow for meters in the range of sizes likely to be used. Friction loss data can be obtained from most manufacturers of water meters.

F102.2 Demand Load

F102.2.1 Estimate the supply demand of the building main and the principal branches and risers of the system by totaling the corresponding demand from the applicable part of Table F102.

F102.2.2 Estimate continuous supply demands in gallons per minute for lawn sprinklers, air conditioners, etc., and add the sum to the total demand for fixtures. The result is the estimated supply demand for the building supply.

F103 SELECTION OF PIPE SIZE

F103.1 General

Decide what is the desirable minimum residual pressure that should be maintained at the highest fixture in the supply system. If the highest group of fixtures contains flush valves, the pressure for the group should be not less than 15 psi (103.4 kPa) flowing. For flush tank supplies, the available pressure may not be less than 8 psi (55.2 kPa) flowing, except blowout action fixtures may not be less than 25 psi (172.4 kPa) flowing.

F103.2 Pipe Sizing

F103.2.1 Pipe sizes may be selected according to the following procedure, except that the sizes selected shall be

not less than the minimum required by the Standard Plumbing Code.

F103.2.2 This water pipe sizing procedure is based on a system of pressure requirements and losses, the sum of which must not exceed the minimum pressure available at the supply source. These pressures are as follows:

1. Pressure required at fixture to produce required flow. See 607.3 and 607.4.
2. Static pressure loss or gain (due to head) is computed at 0.433 psi per foot (9.8 kPa/m) of elevation change. Example: Assume that the highest fixture supply outlet is 20 ft (6.1 m) above or below the supply source. This produces a static pressure differential of 20 ft x 0.433 psi/ft (6.1 m x 9.8 kPa/m) and an 8.66 psi (59.8 kPa) loss.
3. Loss through water meter. The friction or pressure loss can be obtained from meter manufacturers.
4. Loss through taps in water main. See Table F103A.
5. Losses through special devices such as filters, softeners, backflow preventers, and pressure regulators. These values must be obtained from the manufacturers.
6. Loss through valves and fittings, see Tables F103B and F103C. Losses for these items are calculated by converting to equivalent length of piping and adding to the total pipe length.
7. Loss due to pipe friction can be calculated when the pipe size, the pipe length and the flow through the pipe are known. With these three items, the friction loss can be determined using Figures F103A through F103D. When using charts, use pipe inside diameter. For piping flow charts not included, use manufacturers' tables and velocity recommendations.

F103.3 Example

Note: For the purposes of this example the following metric conversions are applicable:

1 cfm = 0.4719 L/s	1 ft ² = 0.0929 m ²
1 degree = 0.0175 rad	1 psi = 6.895 kPa
1 in = 25.4 mm	1 gpm = 0.0631 L/s

Problem: What size copper water pipe, service and distribution will be required to serve a two story factory building having on each floor, back-to-back, two toilet rooms each equipped with hot and cold water? The highest fixture is 21 ft above the street main which is tapped with a 2-inch corporation cock at which point the minimum pressure is 55 psi. In the building basement a 2-inch meter and 3-inch reduced pressure zone backflow preventer with a maximum pressure drop of 9 psi are to be installed. The system is shown by the Example Diagram. To be determined are the pipe sizes for the service main and the cold and hot water distribution pipes.

Solution: A Tabular Arrangement such as shown in Table F101A should first be constructed. The steps to be followed in solving the problem are indicated by the Tabular Arrangement itself as they are in sequence, columns 1 through 10 and lines a through l.

Step 1, Column 1: Divide the system into sections breaking at major changes in elevation or where branches lead to fixture groups. After point B (see figure F103) separate consideration will be given to the hot and cold water piping. Enter the sections to be considered in the service and cold water piping in Column 1 of the Tabular Arrangement. Column 3: According to the method given in F102.2, determine the gpm of flow to be expected in each section of the system. These flows range from 28.6 to 108 gpm.

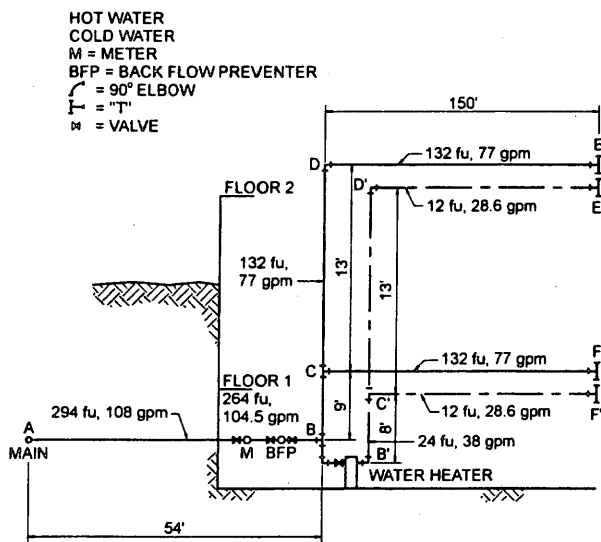

Figure F103
Example — Sizing

Step 2, Line a: Enter the minimum pressure available at the main source of supply in Column 2. This is 55 psi.

Line b: Determine from 607.4 the highest pressure required for the fixtures on system, which is 15 psi, to operate a flushometer valve.

Line c: Determine the pressure loss for the meter size given or assumed. The total water flow from the main through the service as determined in step 1 will serve to aid in the meter selected.

Line d: Select from Table F103A and enter the pressure loss for the tap size given or assumed.

Line e: Determine the difference in elevation between the main or source of supply and the highest fixture on the system and multiply this figure, expressed in feet, by 0.43 psi. Enter the resulting psi product on Line e.

Line f, g, h: The pressure losses through filters, backflow preventers or other special fixtures must be obtained from the manufacturer or estimated and entered on these lines.

Step 3, Line i: The sum of (lines b through h) the pressure requirements and losses which affect the overall system is entered on this line.

Step 4, Line j: Subtract line i from line a. This gives the pressure which remains available from overcoming friction losses in the system. This figure is a guide to the pipe size which is chosen for each section, as the total friction losses through the longest run of pipe.

EXCEPTION: When the main is above the highest fixture, the resulting psi must be considered a pressure gain (static head gain) and omitted from the sums of lines b through h and added to line j.

Step 5, Column 4: Enter the length of each section from the main to the end of the longest run (at Point E).

Step 6, Column 5: Select a trial pipe size. A rule of thumb is that size will become progressively smaller as the system extends farther from the main source of supply. (Trial pipe size may be arrived at by the following formula:)

$$PSI = j \times 100 / \text{Total pipe length}$$

EXAMPLE: $PSI = 9.36 \times 100 / 254 = 3.69$

From main to most remote outlet—Check applicable graph for size for this PSI and GPM

Step 7, Column 6: Select from Table F103B or F103C the equivalent lengths for the trial pipe size of fittings and valves on the section. Enter the sum for each section in Column 6. (The number of fittings to be used in the installation of this piping must be an estimate.)

Step 8, Column 7: Add the figures from Column 4 and Column 6, and enter in Column 7. Express the sum in 100s of feet.

Step 9, Column 8: Select from the applicable figure (F103A through F103D) the friction loss per 100 feet of pipe for the gpm flow in a section (Column 3) and trial pipe size (Column 5).

Step 10, Column 9: Multiply the figures in Columns 7 and 8 for each section and enter in Column 9.

Step 11, Line k: Enter the sum of the values in Column 9.

Step 12, Line l: Subtract Line k from Line j and enter in Column 10.

The result should always be a positive or plus figure. If it is not, it is necessary to repeat the operation utilizing Columns, 5, 6, 8 and 9 until a balance or near balance is obtained. If the difference between lines j and k is positive and large, it is an indication that the pipe sizes are too large and may, therefore, be reduced thus saving materials. In such a case, the operations utilizing Columns 5, 6, 8 and 9 should again be repeated.

Answer: The final figures entered in Column 5 become the

design pipe size for the respective sections. Repeating this operation a second time using the same sketch but considering the demand for hot water, it is possible to size the hot water distribution piping. This has been worked up as a part of the overall problem in the Tabular Arrangement used for sizing the service and cold water distribution piping. It should be noted that consideration must be given the pressure losses from the street main to the water heater (section AB) in determining the hot water pipe sizes.

Table F101A
Recommended Tabular Arrangement for Use in Solving Pipe Sizing Problems

Column	1	2	3	4	5	6	7	8	9	10
Line	Description	Lbs. per square inch (psi)	Gal. per min. through section	Length of section (ft)	Trial pipe size (in)	Equivalent length of fittings and valves (ft)	Total equivalent length col. 4 and col. 6 (100 ft)	Friction loss per 100' of trial size pipe (psi)	Friction loss in equivalent length col. 8 x col. 7 (psi)	Excess pressure over friction losses (psi)
a	Minimum pressure available at main	55.00								
b	Highest pressure required at a fixture (Section 607.4)	15.00								
c	Meter loss 2" meter	11.00								
d	Tap in main loss 2" lap (Table F103A)	1.61								
e	Service and cold water distribution	9.03								
f	Static head loss 21x0.43 psi	9.03								
g	Special fixture loss backflow preventer	9.00								
h	Special fixture loss -Filter	0.00								
i	Special fixture loss -Other	0.00								
j	Total overall losses and requirements (sum of lines b through h)	45.64								
	Pressure available to overcome pipe friction (line a minus lines b to h)	9.36								
		FU								
Designation	AB	294	108.0	54	2 1/2	12	0.66	3.3	2.38	
Pipe section (from diagram)	BC	264	108.0	8	2 1/2	2.5	0.105	3.2	0.34	
Cold water distribution piping	CD	132	77.0	13	2 1/2	8	0.21	1.9	0.40	
	CF	132	77.0	150	2 1/2	12	1.62	1.9	3.08	
	DE	132	77.0	150	2 1/2	14.5	1.645	1.9	3.12	
k	Total pipe friction losses (cold)							6.24		
l	Difference (line j minus line k)					9.36	6.24			3.12
	Pipe section (from diagram)	A' B'	294	108.0	54	2 1/2	9.6	0.64	3.3	2.1
		B' C'	24	38.0	8	2	9.0	0.17	1.4	0.24
	Hot water Distribution Piping	C' D'	12	28.6	13	1 1/2	5	0.18	3.2	0.58
		C' F (Note 2)	12	28.6	150	1 1/2	14	1.64	3.2	5.25
		D' E' (Note 2)	12	28.6	150	1 1/2	7	1.57	3.2	5.02
k	Total pipe friction losses (hot)							7.94		
l	Difference (line j minus line k)					9.36	7.94			1.42

1 psi = 6.895 kPa
1 gpm = 0.0631 L/s
1 ft = 305 mm
1 in = 25.4 mm

Notes:

- To be considered as pressure gain for fixtures below main (consider separately omit from "i" and add to "j").
- Consider separately, in k use C-F only if greater loss than above.

**Table F101B
Load Values Assigned to Fixtures¹**

Fixture	Occupancy	Type of Supply Control	Load Values, in Water Supply Fixture Units		
			Cold	Hot	Total
Bathroom group	Private	Flush tank	2.7	1.5	3.6
Bathroom group	Private	Flush valve	6.0	3.0	8.0
Bathtub	Private	Faucet	1.0	1.0	1.4
Bathtub	Public	Faucet	3.0	3.0	4.0
Bidet	Private	Faucet	1.5	1.5	2.0
Combination fixture	Private	Faucet	2.25	2.25	3.0
Dishwashing machine	Private	Automatic		1.4	1.4
Drinking fountain	Offices, etc.	3/8" valve	0.25		0.25
Kitchen sink	Private	Faucet	1.0	1.0	1.4
Kitchen sink	Hotel, Restaurant	Faucet	3.0	3.0	4.0
Laundry trays (1 to 3)	Private	Faucet	1.0	1.0	1.4
Lavatory	Private	Faucet	0.5	0.5	0.7
Lavatory	Public	Faucet	1.5	1.5	2.0
Service sink	Offices, etc.	Faucet	2.25	2.25	3.0
Shower head	Public	Mixing valve	3.0	3.0	4.0
Shower head	Private	Mixing valve	1.0	1.0	1.4
Urinal	Public	1" flush valve	10.0		10.0
Urinal	Public	3/4" flush valve	5.0		5.0
Urinal	Public	Flush tank	3.0		3.0
Washing machine (8 lbs.)	Private	Automatic	1.0	1.0	1.4
Washing machine (8 lbs.)	Public	Automatic	2.25	2.25	3.0
Washing machine (15 lbs.)	Public	Automatic	3.0	3.0	4.0
Water closet	Private	Flush valve	6.0		6.0
Water closet	Private	Flush tank	2.2		2.2
Water closet	Public	Flush valve	10.0		10.0
Water closet	Public	Flush valve	5.0		5.0
Water closet	Public or Private	Flushometer Tank	2.0		2.0

Note:

1. For fixtures not listed, loads should be assumed by comparing the fixture to one listed using water in similar quantities and at similar rates. The assigned loads for fixtures with both hot and cold water supplies are given for separate hot and cold water loads and for total load, the separate hot and cold water loads being three-fourths of the total load for the fixture in each case.

Table F102
Table for Estimating Demand

Supply Systems Predominantly for Flush Tanks			Supply Systems Predominantly for Flush Valves		
Load	Demand		Load	Demand	
(Water Supply Fixture Units)	(Gallons per Minute)	(Cubic Feet per Minute)	(Water Supply Fixture Units)	(Gallons per Minute)	(Cubic Feet per Minute)
1	3.0	0.04104			
2	5.0	0.0684			
3	6.5	0.86892			
4	8.0	1.06944			
5	9.4	1.256592	5	15.0	2.0052
6	10.7	1.430376	6	17.4	2.326032
7	11.8	1.577424	7	19.8	2.646364
8	12.8	1.711104	8	22.2	2.967696
9	13.7	1.831416	9	24.6	3.288528
10	14.6	1.951728	10	27.0	3.60936
11	15.4	2.058672	11	27.8	3.716304
12	16.0	2.13888	12	28.6	3.823248
13	16.5	2.20572	13	29.4	3.930192
14	17.0	2.27256	14	30.2	4.037136
15	17.5	2.3394	15	31.0	4.14408
16	18.0	2.90624	16	31.8	4.241024
17	18.4	2.459712	17	32.6	4.357968
18	18.8	2.513184	18	33.4	4.464912
19	19.2	2.566656	19	34.2	4.571856
20	19.6	2.620128	20	35.0	4.6788
25	21.5	2.87412	25	38.0	5.07984
30	23.3	3.114744	30	42.0	5.61356
35	24.9	3.328632	35	44.0	5.88192
40	26.3	3.515784	40	46.0	6.14928
45	27.7	3.702936	45	48.0	6.41664
50	29.1	3.890088	50	50.0	6.684
60	32.0	4.27776	60	54.0	7.21872
70	35.0	4.6788	70	58.0	7.75344
80	38.0	5.07984	80	61.2	8.181216
90	41.0	5.48088	90	64.3	8.595624
100	43.5	5.81508	100	67.5	9.0234
120	48.0	6.41664	120	73.0	9.75864
140	52.5	7.0182	140	77.0	10.29336
160	57.0	7.61976	160	81.0	10.82808
180	61.0	8.15448	180	85.5	11.42964
200	65.0	8.6892	200	90.0	12.0312
225	70.0	9.3576	225	95.5	12.76644
250	75.0	10.0260	250	101.0	13.50168
275	80.0	10.6944	275	104.5	13.96956
300	85.0	11.3628	300	108.0	14.43744
400	105.0	14.0364	400	127.0	16.97736
500	124.0	16.57632	500	143.0	19.11624
750	170.0	22.7256	750	177.0	23.66136
1000	208.0	27.80544	1000	208.0	27.80544
1250	239.0	31.94952	1250	239.0	31.94952
1500	269.0	35.95992	1500	269.0	35.95992
1750	297.0	39.70296	1750	297.0	39.70296
2000	325.0	43.446	2000	325.0	43.446
2500	380.0	50.7984	2500	380.0	50.7984
3000	433.0	57.88344	3000	433.0	57.88344
4000	535.0	70.182	4000	525.0	70.182
5000	593.0	79.27224	5000	593.0	79.27224

1 gpm = 0.0631 L/s
1 cfm = 0.4719 L/s

Table F103A
Loss of Pressure Through Taps and Tees
In Pounds Per Square Inch (psi)

Gallons per Minute	Size of tap or tee (in)						
	5/8	3/4	1	1 1/4	1 1/2	2	3
10	1.35	0.64	0.18	0.08			
20	5.38	2.54	0.77	0.31	0.14		
30	12.1	5.72	1.62	0.69	0.33	0.10	
40		10.2	3.07	1.23	0.58	0.18	
50		15.9	4.49	1.92	0.91	0.28	
60			6.46	2.76	1.31	0.40	
70			8.79	3.76	1.78	0.55	0.10
80			11.5	4.90	2.32	0.72	0.13
90			14.5	6.21	2.94	0.91	0.16
100			17.94	7.67	3.63	1.12	0.21
120			25.8	11.0	5.23	1.61	0.30
140			35.2	15.0	7.12	2.20	0.41
150				17.2	8.16	2.52	0.47
160				19.6	9.30	2.92	0.54
180				24.8	11.8	3.62	0.68
200				30.7	14.5	4.48	0.84
225				38.8	18.4	5.6	1.06
250				47.9	22.7	7.00	1.31
275					27.4	7.70	1.59
300					32.6	10.1	1.88

1 in = 25.4 mm
 1 psi = 6.895 kPa

Table F103B
Allowance in Equivalent Length of Pipe for
Friction Loss in Valves and Threaded Fittings (ft)

Fitting or valve	Pipe Sizes (in)							
	1/2	3/4	1	1 1/4	1 1/2	2	2 1/2	3
45° elbow	1.2	1.5	1.8	2.4	3.0	4.0	5.0	6.0
90° elbow	2.0	2.5	3.0	4.0	5.0	7.0	8.0	10.0
Tee, run	0.6	0.8	0.9	1.2	1.5	2.0	2.5	3.0
Tee, branch	3.0	4.0	5.0	6.0	7.0	10.0	12.0	15.0
Gate valve	0.4	0.5	0.6	0.8	1.0	1.3	1.6	2.0
Balancing valve	0.8	1.1	1.5	1.9	2.2	3.0	3.7	4.5
Plug-type cock	0.8	1.1	1.5	1.9	2.2	3.0	3.7	4.5
Check valve, swing	5.6	8.4	11.2	14.0	16.8	22.4	28.0	33.6
Globe valve	15.0	20.0	25.0	35.0	45.0	55.0	65.0	80.0
Angle valve	8.0	12.0	15.0	18.0	22.0	28.0	34.0	40.0

1 in = 25.4 mm
 1 psi = 6.895 kPa
 1 degree = 0.0175 rad

Table F103C
Allowance in Equivalent Length of Tube for
Friction Loss in Valves and Fittings¹ (ft)
(Copper Water Tube)

Fitting or valve	Tube Sizes (in)							
	1/2	3/4	1	1 1/4	1 1/2	2	2 1/2	3
45° elbow (wrought)	0.5	0.5	1.0	1.0	2.0	2.0	3.0	4.0
90° elbow (wrought)	0.5	1.0	1.0	2.0	2.0	2.0	2.0	3.0
Tee, run (wrought)	0.5	0.5	0.5	0.5	1.0	1.0	2.0	—
Tee, branch (wrought)	1.0	2.0	3.0	4.0	5.0	7.0	9.0	—
45° elbow (cast)	0.5	1.0	2.0	2.0	3.0	5.0	8.0	1.0
90° elbow (cast)	1.0	2.0	4.0	5.0	8.0	11.0	14.0	18.0
Tee, run (cast)	0.5	0.5	0.5	1.0	1.0	2.0	2.0	2.0
Tee, branch (cast)	2.0	3.0	5.0	7.0	9.0	12.0	16.0	20.0
Compression Stop	13.0	21.0	30.0	—	—	—	—	—
Globe valve	7.5	10.0	12.5	53.0	66.0	90.0	33	40
Gate valve	0.5	0.25	1.0	1.0	2.0	2.0	2.0	2.0

Note:
 1. From "Copper Tube Handbook" by Copper Development Association, Inc.

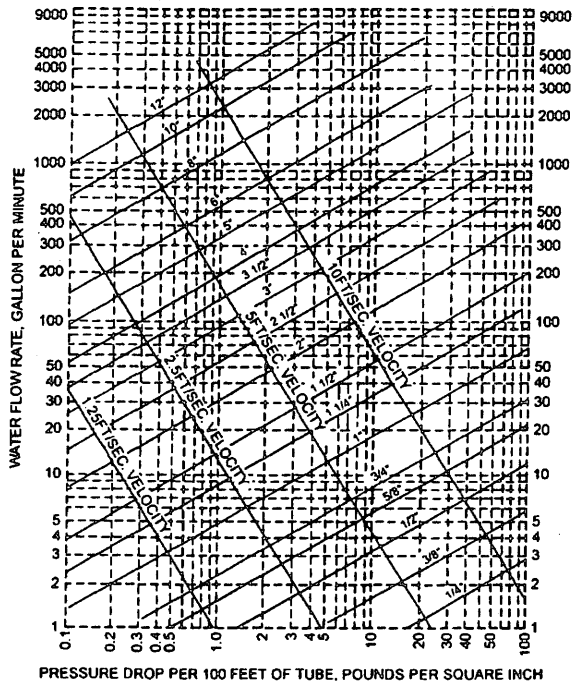

NOTE: FLUID VELOCITIES IN EXCESS OF 5 TO 8 FT/SEC. ARE NOT USUALLY RECOMMENDED

Figure F103A.1
Friction Loss in Smooth Pipe¹
 (Type K, ASTM B88 Copper Tubing)

Note:

1. This chart applies to smooth new copper tubing with recessed (Streamline) soldered joints and to the actual sizes of types indicated on the diagram.

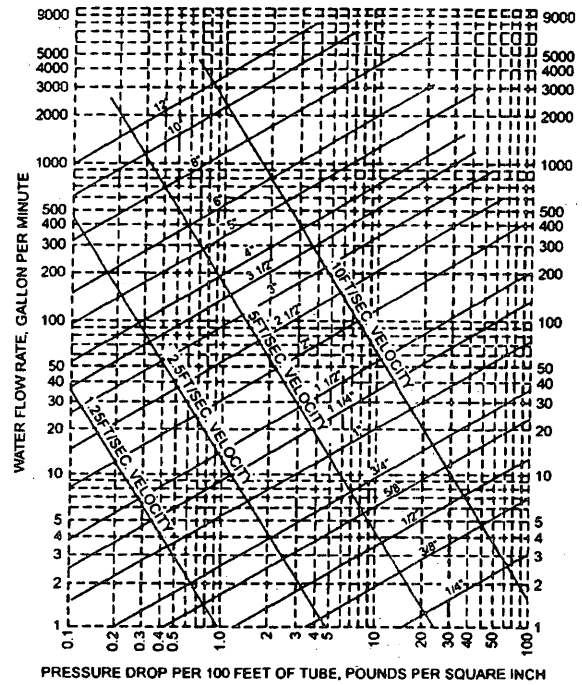

NOTE: FLUID VELOCITIES IN EXCESS OF 5 TO 8 FT/SEC. ARE NOT USUALLY RECOMMENDED

Figure F103A.2
Friction Loss in Smooth Pipe¹
 (Type L, ASTM B88 Copper Tubing)

Note:

1. This chart applies to smooth new copper tubing with recessed (Streamline) soldered joints and to the actual sizes of types indicated on the diagram.

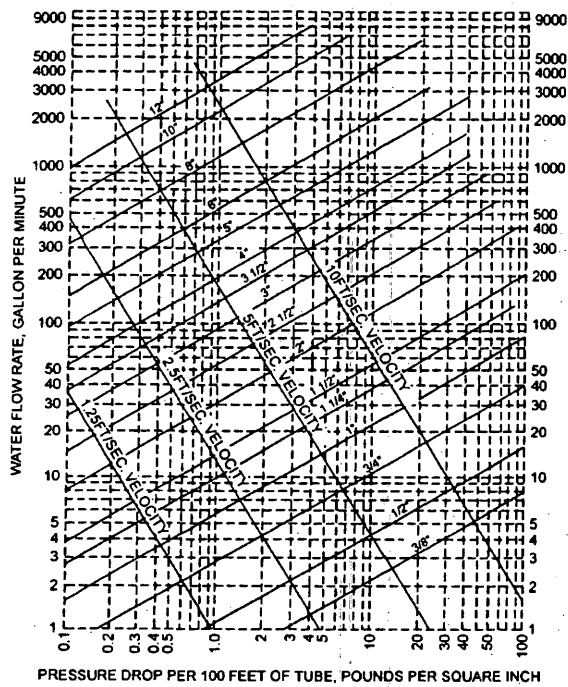

NOTE: FLUID VELOCITIES IN EXCESS OF 5 TO 8 FT/SEC. ARE NOT USUALLY RECOMMENDED

Figure F103A.3
Friction Loss in Smooth Pipe¹

(Type M, ASTM B88 Copper Tubing)

Note:

1. This chart applies to smooth new copper tubing with recessed (Streamline) soldered joints and to the actual sizes of types indicated on the diagram.

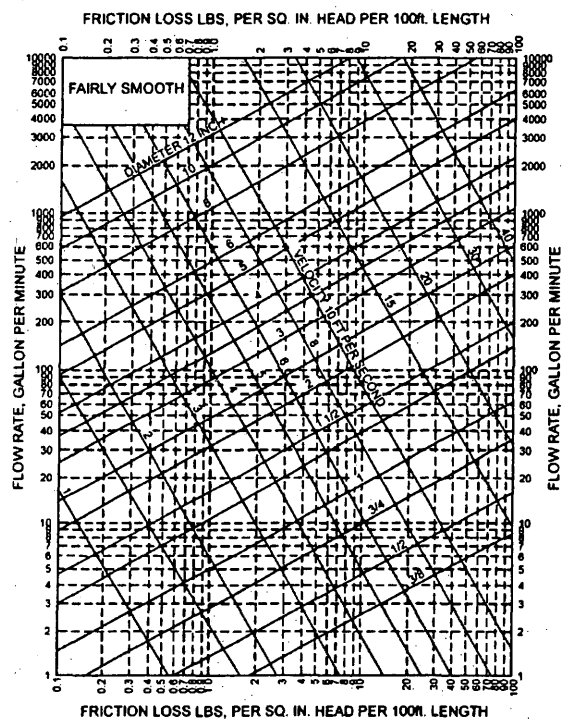

Figure F103B
Friction Loss in Fairly Smooth Pipe¹

Note:

1. This chart applies to new steel (fairly smooth) pipe and to actual diameters of standard-weight pipe.

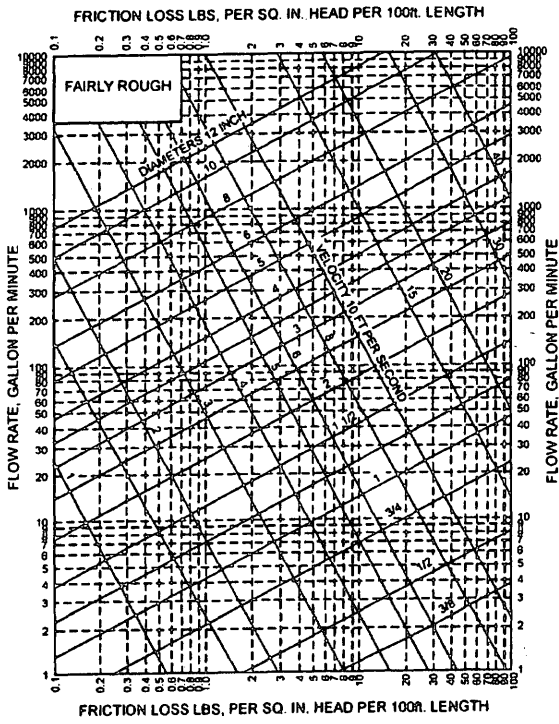

Figure F103C
Friction Loss in Fairly Rough Pipe¹

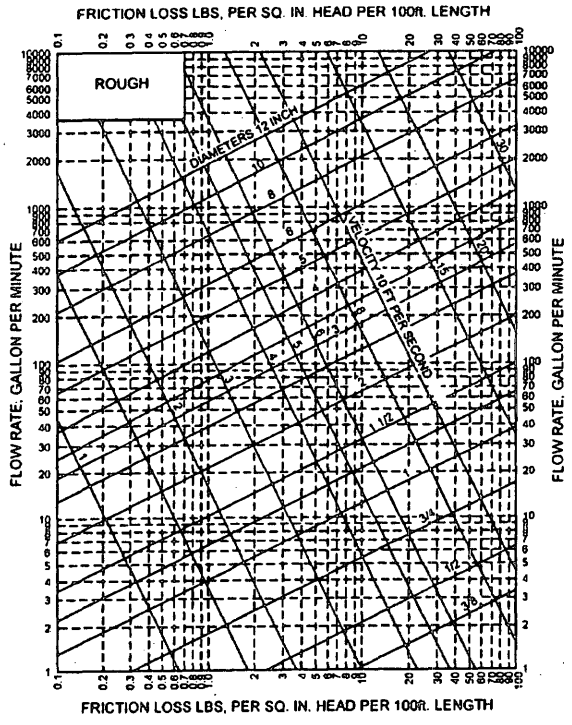

Figure F103D
Friction Loss in Rough Pipe¹

Note:
1. This chart applies to fairly rough pipe and to actual diameters which in general will be less than the actual diameters of the new pipe of the same kind.

Note:
1. This chart applies to very rough pipe and existing pipe and to their actual diameters.

APPENDIX G

MEDICAL FACILITIES PLUMBING SYSTEMS

(APPENDIX G IS A REQUIREMENT OF THIS CODE)

G101 GENERAL

G101.1 Scope

G101.1.1 The provisions of this appendix are intended to set out those items of hospital plumbing systems which differ from plumbing systems in other buildings. Special care shall be accorded the hospital plumbing system because of its direct relationship to adequate medical care and the need for added protection for patients and hospital personnel from health hazards.

G101.1.2 It is understood that hospital plumbing systems shall conform not only to the requirements of this appendix, but also to the requirements contained in the other sections of the Louisiana State Plumbing Code.

G101.1.3 The provisions of this appendix shall apply to special plumbing installations in clinics, doctors offices, nursing homes, and other medical facilities, etc., as well as in hospital installations.

G101.2 Definitions

The following words and terms shall, for the purposes of this chapter and as stated elsewhere in this code, have the meanings shown herein. Refer to Chapter 2 for general definitions.

ASPIRATOR - a fitting or device supplied with water or other fluid under positive pressure which passes through an integral orifice or constriction causing a vacuum. Aspirators are often referred to as suction apparatus, and are similar in operation to an ejector.

AUTOPSY TABLE - a fixture or table used for post-mortem examination of a body.

BEDPAN HOPPER - see Clinical Sink.

BEDPAN STEAMER OR BOILER - a fixture used for scalding bedpans or urinals by direct application of steam or boiling water.

BEDPAN UNIT - a small workroom in the nursing area designed and equipped for emptying, cleaning, and sometimes for steaming bedpans, and for no other purpose.

BEDPAN WASHER AND STERILIZER - a fixture designed to wash bedpans and to flush the contents into the sanitary drainage system. It may also provide for emptying, cleaning, and sometimes for steaming bedpans, and for no other purpose.

BEDPAN WASHER HOSE - a device supplied with hot and cold water and located adjacent to a water closet or clinical sink to be used for cleansing bedpans.

Louisiana State Plumbing Code, 2000 edition®

CLINICAL SINK (BEDPAN HOPPER) - a fixture meeting the design requirements of G102.1 for the rinsing of bedpans and soiled linen. Such fixtures shall have a trap size of not less than 3 inches.

EFFECTIVE OPENING - the minimum cross-sectional area at the point of water supply discharge, measured or expressed in terms of (1) diameter of a circle, or (2) if the opening is not circular, the diameter of a circle of equivalent cross-sectional area. Applicable to air gap.

NURSES' STATION - an area in the nursing unit separated from the corridor by counter or desk, designed to permit nurses to record and file each patient's history and progress, observation and control of corridor, preparation of medicines and maintain contact with patients, the hospital and the outside by local and public means of communication.

SCRUB SINK - a device usually located in the operating suite to enable operating personnel to scrub their hands prior to operating procedure. The hot and cold water supply is activated by a knee-action mixing valve or by wrist or pedal control.

STERILIZER, BOILING TYPE - a fixture (nonpressure type) used for boiling instruments, utensils, and other equipment (used for disinfection). Some devices are portable, others are connected to the plumbing system.

STERILIZER, INSTRUMENT - a device for the sterilization of various instruments.

STERILIZER, PRESSURE INSTRUMENT WASHER-STERILIZER - a fixture (pressure vessel) designed to both wash and sterilize instruments during the operating cycle of the fixture.

STERILIZER, PRESSURE (AUTOCLAVE) - a fixture (pressure vessel) designed to use steam under pressure for sterilizing. Also called an autoclave.

STERILIZER, UTENSIL - a device for sterilization of utensils as used in hospital services.

STERILIZER VENT - a separate pipe or stack, indirectly connected to the building drainage system at the lower terminal, which receives the vapors from nonpressure sterilizers, or the exhaust vapors from pressure sterilizers, and conducts the vapors directly to the outer air. Sometimes called vapor, steam, atmospheric, or exhaust vent.

STERILIZER, WATER - a device for sterilizing water and storing sterile water.

STILL - a device used in distilling liquids.

UTILITY ROOM - a workroom in the patient nursing area, designed and equipped to facilitate preparation, cleaning and incidental sterilization of the various supplies, instruments, utensils, etc. involved in nursing treatment and care, exclusive of medications handled in nurses' stations and bedpan cleaning and sterilizing.

G102 FIXTURES

G102.1 Bedpans

Acceptable flush rim bedpan hoppers (clinic sink), bedpan washers, and/or other acceptable fixtures and equipment shall be provided for the disposing of bedpan contents and the cleansing and disinfection of bedpans in soiled utility (hopper) rooms.

G102.2 Clinic Sink

A clinic sink shall have an integral trap in which the upper portion of a visible trap seal provides a water surface. The fixture shall be so designed as to permit complete removal of the contents by siphonic or blowout action, or both, and to reseal the trap. A flushing rim shall provide water to cleanse the interior surface. The fixture shall have flushing and cleansing characteristics similar to a water closet.

G102.3 Prohibited Use of Clinic and Service Sinks

A clinic sink serving a soiled utility room shall not be considered as a substitute for, nor shall it be used as, a janitor's service sink. A janitor's service sink shall not be used for the disposal of urine, fecal matter, or other human waste.

G102.4 Ice Prohibited in Soiled Utility Room

Machines for manufacturing ice, or any device for the handling or storage of ice, shall not be located in a soiled utility room. Machines for manufacturing ice, or devices for handling or storage of ice intended for either human consumption or packs, may be located in a clean utility room, floor pantry, or diet kitchen.

G102.5 Sterilizer Equipment Requirements

G102.5.1 It shall be unlawful to descale or otherwise submit the interior of water sterilizers, stills, or similar equipment to acid or other chemical solutions while the equipment is connected to the water or drainage system.

G102.5.2 New pressure sterilizers and pressure instrument washer-sterilizers hereafter installed shall display, in a location clearly visible at all times, the ASME Standard symbol and data plate.

G102.5.3 All sterilizer piping and devices necessary for the operation of sterilizers shall be accessible for inspection and maintenance, and shall satisfy the following:

1. Steam supplies to sterilizers, including those connected by pipes from overhead mains or branches, shall be drained to prevent any excess moisture from reaching the sterilizer. The condensate drainage from the steam supply shall be discharged by gravity.

2. Steam condensate return from sterilizers shall not be connected to pressure or vacuum return systems; only gravity returns shall be acceptable. Steam condensate returns from sterilizers shall not be connected to overhead mains or branches.
3. Pressure sterilizers should be equipped with an acceptable means of condensing and cooling the exhaust steam vapors. Nonpressure sterilizers should be equipped with an acceptable device which will automatically control the vapors in a manner so as to confine them within the vessel, or equipped with an acceptable means of condensing and cooling the vapors.
4. Gas fired equipment or apparatus, requiring either water or drainage connections or both, shall meet the standards of the American National Standards Institute.

G102.6 Special Elevations

Control valves, vacuum outlets, and devices which protrude from a wall of an opening, emergency, recovery, examining, or delivery room, or in a corridor or other locations where patients may be transported on a wheeled stretcher, shall be so located at an elevation which will preclude bumping the patient or stretcher against the device. When necessary to install at a low elevation, safety precautions should be taken to protect the personnel.

G102.7 Plumbing in Mental Hospitals

In mental hospitals, special consideration should be given to piping, controls and fittings of plumbing fixtures as required by the types of mental patients being treated. Pipes or traps should not be exposed, and fixtures should be substantially bolted through walls.

G103 DRAINAGE AND VENTING

G103.1 Ice Storage Chest Drains

Any drain serving an ice storage chest or box shall discharge over an indirect waste receptor separate from all other fixture wastes. Each terminal shall discharge through an air gap above the receptor. The end shall be covered with a removable screen of not less than 10 mesh per square inch (15.5 mesh per 1000 sq mm), and if discharging vertically, the terminal shall be cut at an angle of 45° (0.785 rad).

G103.2 Bedpan Washers and Clinic Sinks

Bedpan washers and clinic sinks shall be connected to the soil pipe system and vented following the requirements as applied to water closets, except that bedpan washers require additional local vents.

G103.3 Sterilizer Wastes

G103.3.1 Indirect Wastes Required. All sterilizers shall be provided with individual and separate indirect wastes, with air gaps of not less than two diameters of the waste tailpiece. The upper rim of the receptor, funnel, or basket type waste fitting shall be not less than 2 inches (51 mm) below the vessel or piping, whichever is lower. Except as provided in G103.3.2 and G103.3.4, a "P" trap shall be

Louisiana State Plumbing Code, 2000 edition®

installed on the discharge side of, and immediately below, the indirect waste connection serving each sterilizer.

G103.3.2 Recess Room Floor Drain.

G103.3.2.1 In all recess rooms containing the recessed or concealed portions of sterilizers, not less than one acceptable floor drain, connecting to the drainage system, shall be installed in a manner to drain the entire floor area.

G103.3.2.2 The recess room floor drain waste and trap shall be a minimum diameter of 3 in (76 mm). It shall receive the drainage from at least one sterilizer within the recess room to assure maintenance of the floor drain trap seal. The sterilizer drain shall be installed on a branch taken off between the floor drain trap and the drain head. An individual waste trap shall not be required on this type of installation.

G103.3.3 Prohibited Connections. Branch funnel and branch basket type fittings, except as provided in G103.3.4, are prohibited on any new installation or when relocating existing equipment. Existing branch funnel or branch basket type installations shall be provided with an acceptable indirect waste below the branch connections.

G103.3.4 Battery Assemblies. A battery assembly of not more than three sterilizer wastes may drain to one trap, provided the trap and waste are sized according to the combined fixture unit rating, the trap is located immediately below one of the indirect waste connections, the developed distance of a branch does not exceed 8 ft (2438 mm), and the branches change direction through a tee-wye or wye pattern fitting.

G103.3.5 Bedpan Steamers, Additional Trap Required. A trap with a minimum seal of 3 inches (76 mm) shall be provided in a bedpan steamer drain located between the fixture and the indirect waste connection.

G103.3.6 Pressure Sterilizer. Except when an exhaust condenser is used, a pressure sterilizer chamber drain may be connected to the exhaust drip tube before terminating at the indirect waste connection. If a vapor trap is used, it shall be designed and installed to prevent moisture being aspirated into the sterilizer chamber. The jacket steam condensate return, if not connected to a gravity steam condensate return, shall be separately and indirectly wasted. If necessary to cool a high temperature discharge, a cooling receiver, trapped on its discharge side, may serve as the fixture trap.

G103.3.7 Pressure Sterilizer Exhaust Condensers. The drain from the condenser shall be installed with an indirect waste as prescribed in this code. If condensers are used on pressure sterilizers, the chamber drain shall have a separate indirect waste connection.

G103.3.8 Water Sterilizer. All water sterilizer drains,

including tank, valve leakage, condenser, filter and cooling, shall be installed with indirect waste or according to G103.3.2.1.

G103.3.9 Pressure Instrument Washer-Sterilizer. The pressure instrument washer-sterilizer chamber drain and overflow may be interconnected. Also, they may be interconnected with the condensers. The indirect waste shall follow the provision set forth in this code.

G103.4 Aspirators

In operating rooms, emergency rooms, recovery rooms, delivery rooms, examining rooms, autopsy rooms, and other locations except laboratories, where aspirators are installed for removing blood, pus, or other fluids, the discharge from any aspirator shall be indirectly connected to the drainage system. The suction line shall be provided with a bottle or similar trap to protect the water supply.

G103.5 Vacuum System Stations

Vacuum system station locations shall be considered from the standpoint of convenience and practical use. The receptacles should be built into cabinets or recesses but shall be visible and readily accessible.

G103.6 Bottle System

Vacuum (fluid suction) systems intended for collecting, removing or disposing of blood, pus or other fluids by the so-called bottle system shall be provided with receptacles, which are equipped with an overflow preventative device, at each vacuum outlet station. Each vacuum outlet station should be equipped with a secondary safety receptacle as an additional safeguard against fluids, other than air entering the vacuum piping systems.

G103.7 Central Disposal System Equipment

All central vacuum (fluid suction) systems shall assure continuous service. Systems equipped with collecting or control tanks shall provide for draining and cleaning of the tanks while the system is in operation. In hospitals or institutions having emergency power provisions, the system shall be capable of remaining in service during the use of emergency power. The exhausts from a vacuum pump used in connection with a vacuum (fluid suction) system shall discharge separately to the outer atmosphere. The exhaust discharge shall not create a nuisance or hazard within, without, around or about the premises. Termination of the exhaust to the atmosphere shall be the same as required for sanitary sewer vents.

G103.8 Central Vacuum and Disposal Systems

G103.8.1 The waste from a central vacuum (fluid suction) system of the disposal type which is connected to the drainage system, whether the disposal be by barometric lag, collection tanks, or bottles, shall be directly connected to the sanitary drainage system through a trapped waste.

G103.8.2 The piping of a central vacuum (fluid suction) system shall be of corrosion resistant material having a smooth interior surface. A branch shall not be less than 1/2

inch for one outlet and sized according to the number of vacuum outlets, and a main shall not be less than 1 inch. The pipe sizing shall be increased according to acceptable engineering practices. All piping shall be provided with adequate, and accessible cleanout facilities on mains, and branches, and shall be accessible for inspection, maintenance, and replacements.

G103.9 Water Systems for Space Cooling and Heating Condensate Drains

The lowest point of a condensate riser or risers shall be trapped and discharged over an indirect waste sink. The trap may be either "P" or a "running trap" with a cleanout. A branch shall be installed upstream from the condensate drain trap for flushing and resealing purposes. The condensate drain and trap shall be located above the lowest floor level of the building.

G103.10 Vent Material

Material for local vents serving bedpan washers and sterilizer vents serving sterilizers shall be sufficiently rust proof, erosion and corrosion resistant to withstand intermittent wetting and drying from steam vapors, to withstand the distilled water solvent action of the steam vapors and to withstand frequent and immediate changes of temperatures.

G103.11 Vent Connections Prohibited

Connections between local vents serving bedpan washers, sterilizer vents serving sterilizing apparatus and normal sanitary plumbing systems are prohibited. Furthermore, only one type of apparatus shall be served by a given vent.

G103.12 Local Vents and Stacks

G103.12.1 Bedpan washers shall be vented to the outer atmosphere by means of one or more local vents. Termination of the vent to the atmosphere shall be the same as required for sanitary sewer vents. The local vent for a bedpan washer shall not be less than a 2-inch diameter pipe. A local vent serving a single bedpan washer may drain to the fixture served.

G103.12.2 Where bedpan washers are located above each other on more than one floor, a local vent stack may be installed to receive the local vent on the various floors. More than three bedpan washers shall not be connected to a 2-inch local vent stack, six to a 3-inch local vent stack, and 12 to a 4-inch local vent stack. In multiple installations, the connections between a bedpan washer local vent and a local vent stack shall be made by use of the tee or tee-wye sanitary pattern drainage fittings, installed in an upright position.

G103.12.3 The bottom of the local vent stack, except when serving only one bedpan washer, shall be drained by means of a trapped and vented waste connection to the plumbing sanitary drainage system. The trap and waste shall be the same as the local vent stack.

G103.12.4 A water supply of not less than 1/4 inch minimum tubing shall be taken from the flush supply of

each bedpan washer on the discharge or fixture side of the vacuum breaker, trapped to form not less than a 3-inch (76 mm) seal, and connected to the local vent stack on each floor. The water supply shall be so installed as to provide a supply of water to the local vent stack for cleansing and drain trap seal maintenance each time a bedpan washer is flushed.

G103.13 Sterilizer Vents and Stacks

G103.13.1 Multiple installations of pressure and nonpressure sterilizers shall have their vent connections to the sterilizer vent stack made by means of inverted wye fittings. Such vent connections shall be accessible for inspection and maintenance.

G103.13.2 The connection between sterilizer vent or exhaust openings and the sterilizer vent stack shall be designed and installed to drain to the funnel or basket type waste fitting. In multiple installations, the sterilizer vent stack shall be drained separately to the lowest sterilizer funnel or basket type waste fitting or receptor.

G103.14 Sterilizer Vent Stack Sizes

G103.14.1 The minimum diameter of a sterilizer vent serving a bedpan steamer shall be 1 1/2 inches. Multiple installations shall be sized according to Table G103.14A.

G103.14.2 The minimum diameter of a sterilizer vent stack shall be 2 inches when serving a utensil sterilizer, and 1 1/2 inches when serving an instrument sterilizer. Combinations of boiling type sterilizer vent connections shall be based on Table G103.14A.

G103.14.3 Sterilizer vent stacks shall be 2 1/2 inches minimum; those serving combinations of pressure sterilizer exhaust connections shall be sized according to Table G103.14B.

G103.14.4 The minimum diameter of a sterilizer vent stack serving an instrument washer-sterilizer shall be 2-inch diameter. Not more than two sterilizers shall be installed on a 2-inch stack, and not more than four on a 3-inch stack.

Table G103.14A
Stack Sizes For Bedpan Steamers and
Boiling Type Sterilizers (in)
 (Number of connections of various sizes permitted to various sized sterilizer vent stacks)

Stack size (in)	Connection size (in)		
	1 1/2		2
1 1/2 (Note 1)	1	or	0
2	2	or	1
2 (Note 2)	1	and	1
3 (Note 1)	4	or	2
3 (Note 2)	2	and	2
4 (Note 1)	8	or	4
4 (Note 2)	4	and	4

1 in = 25.4 mm

Notes:

1. Total of each size.
2. Combination of sizes.

Table G103.14B
Stack Sizes for Pressure Sterilizers (in)
 (Number of connections of various sizes permitted to various sized vent stacks)

Stack size (in)	Connection size (in)			
	3/4	1	1 1/4	1 1/2
1 1/2 (Note 1)	3 or	2 or	1 or	1
1 1/2 (Note 2)	2 and	1		
2 (Note 1)	6 or	3 or	2 or	1
2 (Note 2)	3 and	2		
2 (Note 2)	2 and	1 and	1	
2 (Note 2)	1 and	1 and	1	
3 (Note 1)	15 or	7 or	5 or	3
3 (Note 2)		1 and	2 and	2
	1 and	5 and		1

1 in = 25.4 mm

Notes:

1. Total of each size.
2. Combination of sizes.

G103.15 All radioactive materials shall be disposed of in a manner so as not to create a hazard to operation and maintenance personnel of the institution or to the public. Specific permission shall be secured from the proper authority to dispose of any radioactive material to the drainage system.

G104 WATER SUPPLY

G104.1 Water Service

It is recommended that all hospitals have dual services installed in a manner to provide an uninterrupted supply of water in case of a water main break.

G104.3 Hot Water Supply System

Hot water circulating mains and risers should be run from the hot water storage tank to a point directly below the highest fixture at the end of each branch main. Where the building is higher than three stories, each riser shall be circulated. Each main, branch main, riser and branch to a group of fixtures of the water system shall be valved.

G104.4 Vacuum Breaker Installations

G104.4.1 For ordinary hose connections, the maximum height at which any hose is to be used shall be treated as its flood level.

G104.4.2 Where low volume flows might cause leaking or spitting at the vacuum breaker parts, back pressure may be developed by installing an acceptable minimum orifice valve on the discharge side of the vacuum breaker. This shall be in addition to the regular control valve. This type of installation shall be subject to review and acceptance by the plumbing official before installation.

G104.5 Prohibited Water Closet and Clinic Sink Supply

Jet or water supplied orifices, except those supplied by the flush connections, shall not be located in or connected with a water closet bowl or clinic sink. This section shall not prohibit an acceptable bidet installation.

G104.6 Special Equipment, Water Supply Protection

Table G104.6 sets forth the requirements which shall be followed in protecting the water supply for hospital fixtures against backflow or back-siphonage.

G104.7 Clinical, Hydrotherapeutic and Radiological Equipment

All clinical, hydrotherapeutic, radiological, or any equipment, whether mentioned or not, which is water supplied or discharges to the waste system, shall meet the requirements of this section and the code covering cross connectors, air gaps, vacuum breakers, and check valves. Special equipment and devices found under these classes include those listed in Table G104.7.

Table G104.6
Fixtures and Their Water Supply Protection

Fixtures	Type of protection ¹	Remarks
Aspirators:		
Laboratory	Vacuum breaker	
Portable	Vacuum breaker	
Vacuum system	Vacuum breaker	
Bedpan:		
Washers	Vacuum breaker	
Washer hose	Vacuum breaker	Locate 5 ft above floor
Boiling type sterilizer	Air gap	Not less than twice the effective opening of the water supply
Exhaust condenser	Vacuum breaker	
Flush floor drain	Vacuum breaker	Locate 6 ft above floor
Hose connection	Vacuum breaker	
Pressure instrument washer-sterilizer	Vacuum breaker	
Pressure sterilizer	Vacuum breaker	
Vacuum systems:		
Cleaning	Air gap or vacuum breaker	
Fluid suction	Air gap or vacuum breaker	

1 ft = 304.8 mm

Note:

1. Where atmospheric vacuum breakers are used, they shall be installed after the last control valve.

G104.8 Condensate Drain Trap Seal

A water supply shall be provided for cleaning, flushing, and resealing the condensate trap. The source of the water supply shall be a refrigerator condenser discharge, a drinking fountain waste, or other acceptable method of flushing and releasing the trap. The water supply shall be not less than one-half inch diameter pipe and shall discharge through an air gap not less than twice the diameter of the supply pipe.

G104.9 Valve Leakage Diverter

Each water sterilizer which may be filled with water through directly connected piping shall be equipped with an acceptable leakage diverter and/or bleed-line on the water supply control valve to indicate and conduct any leakage of unsterile water away from the sterile zone.

Table G104.7
Classes of Clinical, Hydrotherapeutic and Radiological Equipment

Clinical	Hydrotherapeutic	Radiological	Other
Dental cuspidors	Control units	Diagnostic x-ray	Violet ray
Surgical cuspidors	Arm bath	Therapy x-ray	Photographic
Dental (flush rim) lavatories	Leg bath	X-ray transformers	developing
Sitz bath	Tub bath	X-ray oil tank	Film
Emergency bath	Immersion bath	Diffraction	developing
Receiving bath	Shower bath	X-ray developing	Microscopic
Prenatal bath	Needle bath		
Infant bath	Tank		
Prophylaxis	Pool		
Shampoo	Hose		
Massage	Syringe douche		

G105 MEDICAL GASES

Where medical gases are installed, the gas piping, outlets, manifold rooms and storage rooms shall be installed in accordance with the requirements of the NFPA 99.

APPENDIX H PERMIT FEES

(Note: Appendix H deleted without substitution.)

00000000



APPENDIX I INSTALLATION OF BUILDING SEWERS

(APPENDIX I IS A REQUIREMENT OF THIS CODE)

I101 CAST IRON SOIL PIPE

I101.1 Trench Construction

Pipe shall be installed in as narrow a trench as possible while providing sufficient width for joint assembly.

I101.2 Bedding

Pipe shall be installed so that the trench bottom provides support of the pipe barrel. Hub holes and coupling holes shall be provided.

I101.3 Rock

When rock larger than 1 1/2 inches (38.1 mm) in diameter is encountered during installation, it shall be removed from the trench bottom and a 6 inch (152.4 mm) layer of selected fill shall be added to provide uniform support.

I101.4 Backfilling

Backfill trench following test. When backfilling, care shall be taken to protect the pipe from large rocks, stone, or frozen fill material which could damage the pipe.

I103 CLAY PIPE

I103.1 Trench and Material Preparation

I103.1.1 Width of trenches in which clay pipe is to be installed shall be such as to provide adequate space for workmen to place and joint the pipe properly.

I103.1.2 Bell holes shall be excavated so that, after placement, only the barrel of the pipe receives bearing pressure from the trench bottom.

I103.1.3 Preparation of the trench bottom and placement of the pipe shall be carefully done so that, when in final position, the pipe is true to line and grade.

I103.1.4 Pipe shall be protected during handling against impact shock and free fall. No pipe shall be used in the work which does not conform to the appropriate ASTM standard.

I103.2 Pipe Laying and Joining

I103.2.1 The laying of pipe in finished trenches shall be commenced at the lowest point, with the spigot ends pointing in the direction of flow.

I103.2.2 All pipe shall be laid with ends abutting and true to line and grade. They shall be carefully centered, so that when laid they will form a sewer with a uniform invert.

I103.2.3 Pipe shall be set firmly according to line and grade, and, preparatory to making pipe joints, all surfaces of the portion of the pipe to be joined shall be cleaned and dried. The joints shall then be carefully adjusted and filled with the jointing material.

I103.2.4 Trenches shall be kept water-free during joining and for a sufficient period thereafter to allow the jointing material to become fully set and completely resistant to water penetration. Trenches shall be backfilled immediately after pipe is laid therein to prevent dislocation of the sewer line or jointing material, except when factory applied flexible compression joints are used.

I103.3 Testing

The sewer line will be tested as required in Chapter 3, or as prescribed by local authority.

1104 PLASTIC PIPE

1104.1 Trenching and Supporting

1104.1.1 Trenching—Excavate to desired grade. Use template to detect high spots and holes. Fill holes and depressions, tamping thoroughly.

1104.1.2 Where trenching conditions are difficult, pipe shall be uniformly supported throughout using treated timber, concrete pad, sand, or select backfill properly tamped.

1104.2 Laying Bedding and Backfilling

1104.2.1 Lay the pipe line as described. Be sure the pipe is bedded in the selected backfill one-fourth to one-third of the pipe diameter. Under no circumstances should bricks or other supports be used to bring pipe to grade.

1104.2.2 After pipe is bedded and checked for grade, additional selected backfill is placed by shovel at sides and over top of pipe and tamped. By careful tamping at this point, the pipe can support a much greater load and is less likely to be subsequently disturbed or shifted.

1104.2.3 Reasonably clean backfill shall be placed 12 inches (305 mm) over the pipe.

1104.2.4 The trench may now be backfilled by any conventional means, bulldozer, loader, etc., and the pipe is protected.

APPENDIX J ILLUSTRATIONS

(APPENDIX J IS FOR INFORMATIONAL PURPOSES ONLY)

The following figures have been included in the 1994 edition of the Standard Plumbing Code to aid in interpreting this code. The figures are not to be construed as superseding the written text, but merely to illustrate. The various methods indicated diagrammatically do not limit other configurations of design of plumbing, soil, waste and vent systems, water piping, accessories, etc., when in compliance with the written text. It is further suggested that the users of these illustrations refer to the appropriate sections and standards regarding any of the figures to avoid misunderstanding.

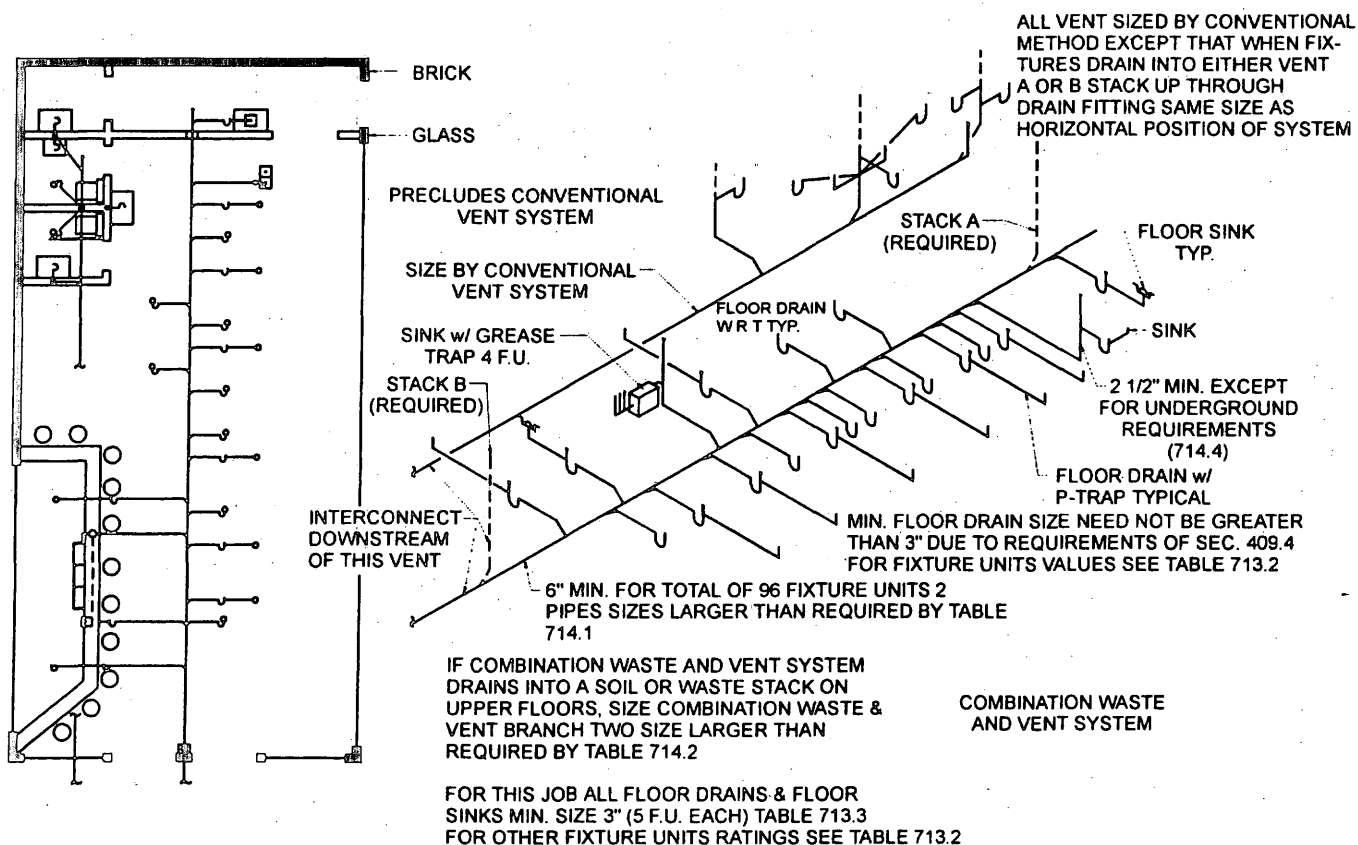

Figure 6

EXAMPLES OF DISTANCES PERMITTED
IN A COMBINATION WASTE AND VENT SYSTEM

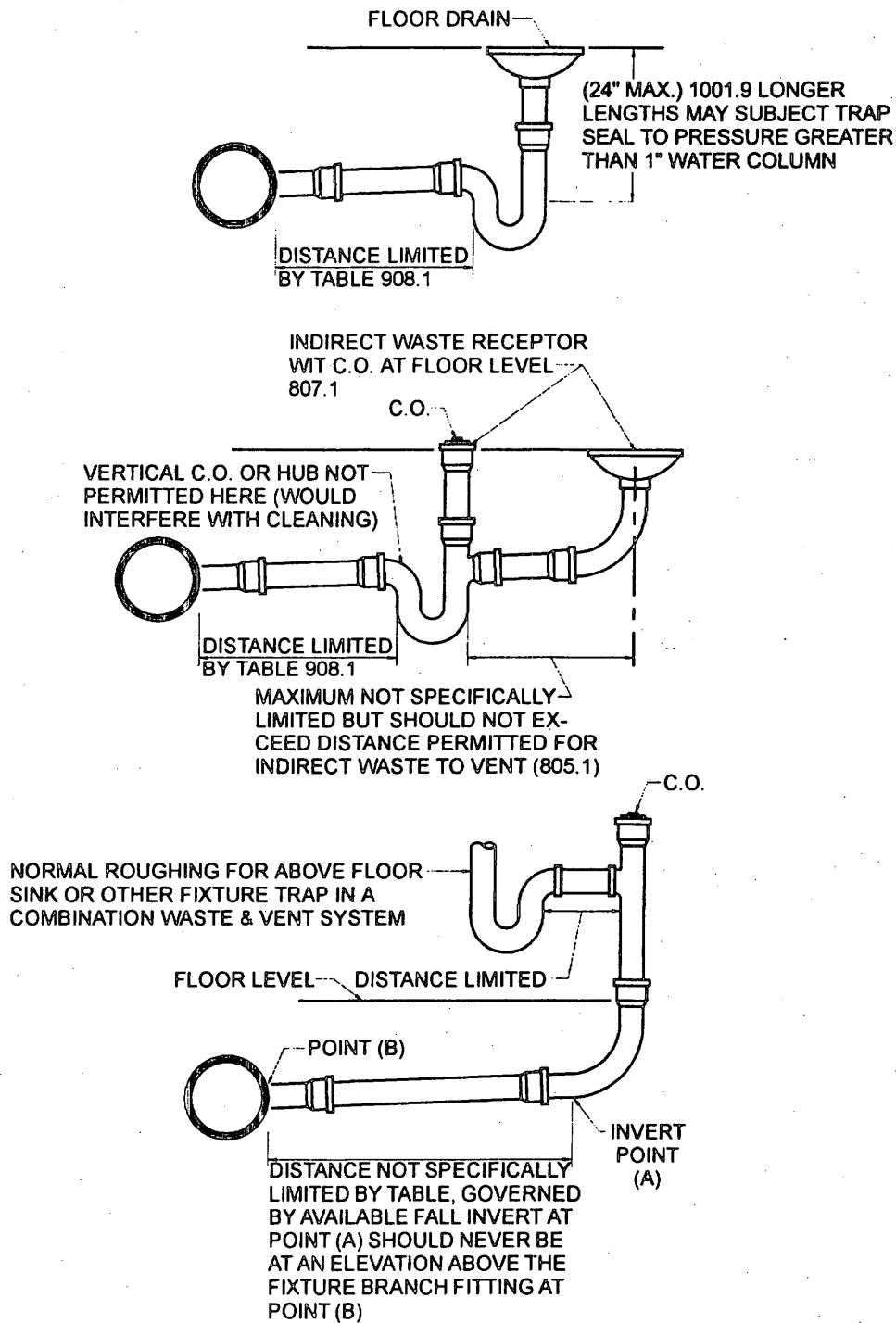
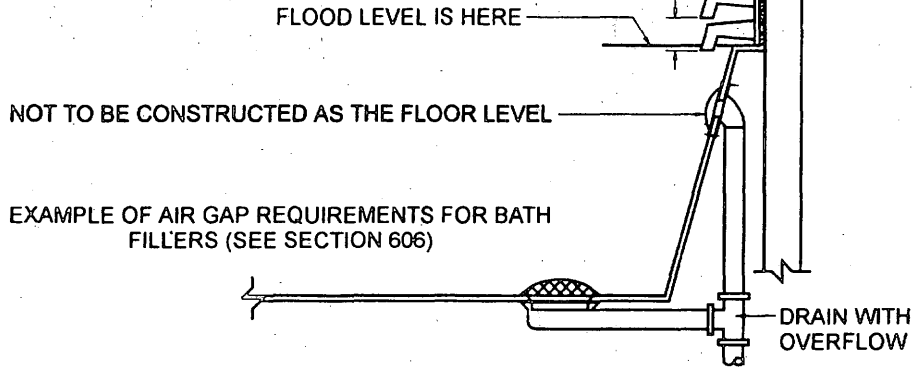
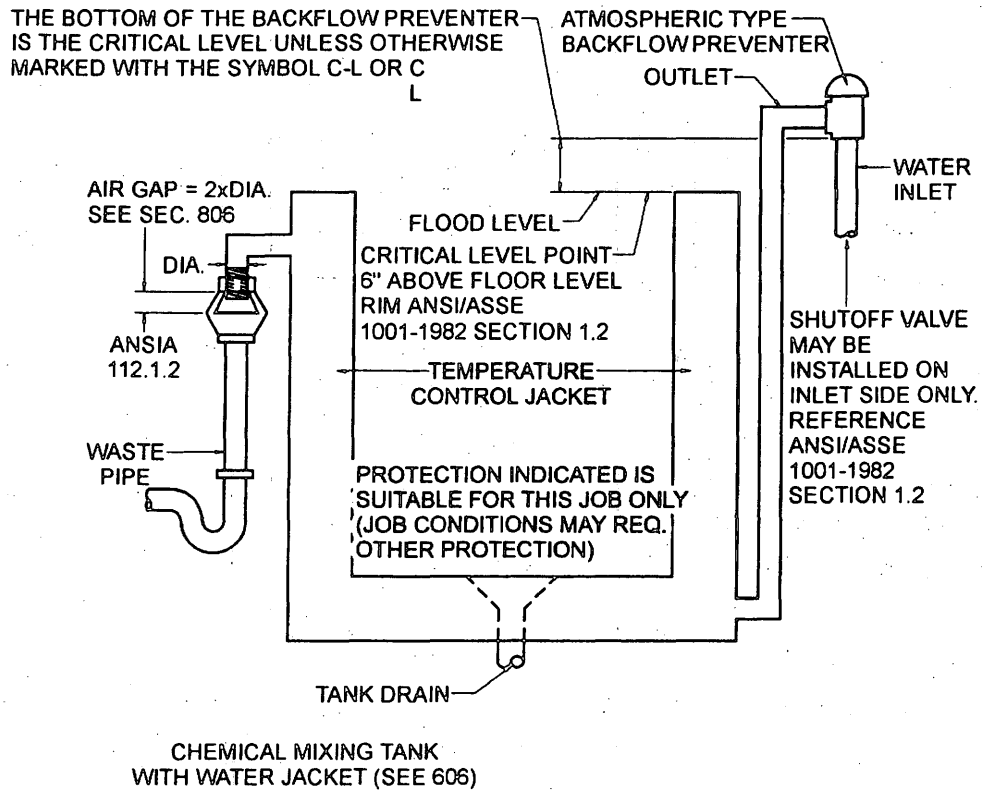

Figure 7

FOR OVER RIM BATH FILLERS MINIMUM AIR GAP-2"
 FOR OPENINGS 1" OR LESS IN DIA. FOR LARGER
 OPENINGS & EFFECTS ON SIDE WALLS
 SEE ANSI A112.1.2



EXAMPLE OF AIR GAP REQUIREMENTS FOR BATH
 FILLERS (SEE SECTION 606)



CHEMICAL MIXING TANK
 WITH WATER JACKET (SEE 606)

Figure 8

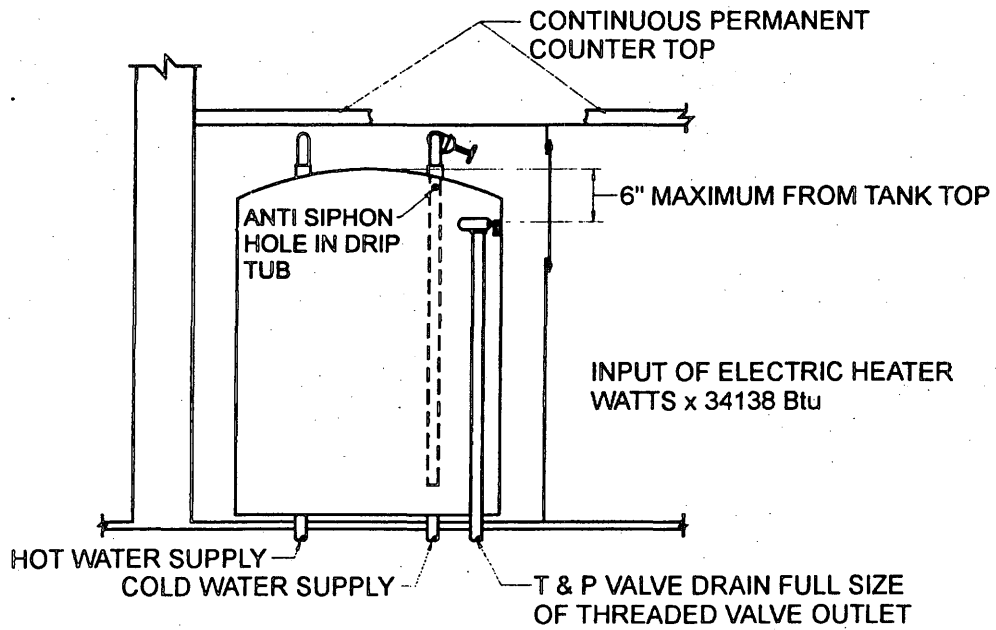
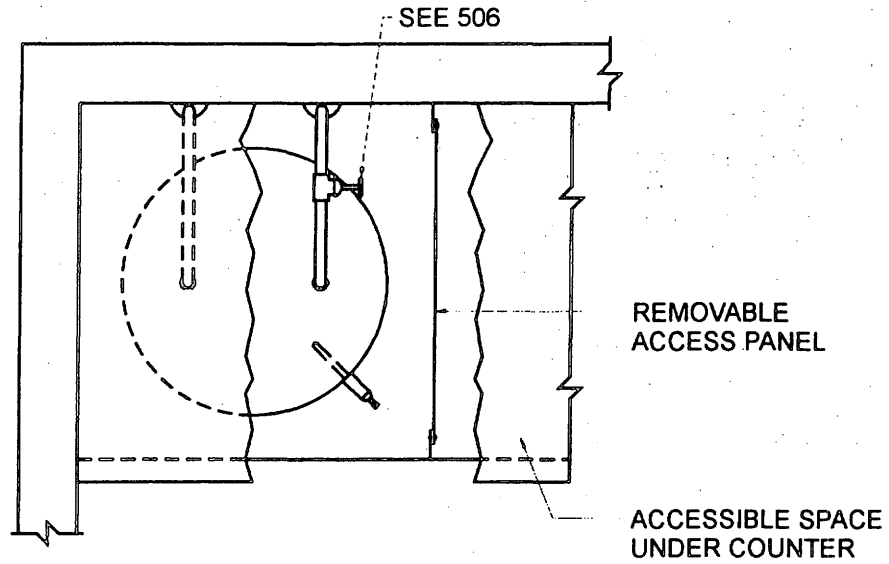

EXAMPLE OF BUILT IN WATER HEATER WITH ACCESS TO RELIEF VALVE & SHUTOFF VALVE

Figure 9

APPROVED ONLY WHEN OUTLET OF VACUUM BREAKER OPEN TO ATMOSPHERE

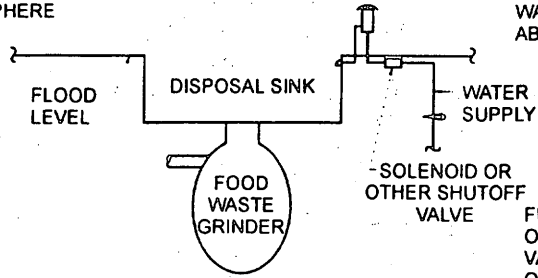

TO PROVIDED PROTECTION, VACUUM RELIEF VALVE MUST BE IN COLD WATER SUPPLY AND LOCATED ABOVE TANK TOP

VACUUM RELIEF VALVE (SEE SEC. 507.1) REQUIRED ON BOTTOM INLET TANKS OR TANKS NOT EQUIPPED WITH ANTI-SIPHON TUBES.

NOT APPROVED SOLENOID VALVE CLOSES OFF VACUUM BREAKER OUTLET PLACING VACUUM BREAKER UNDER CONSTANT PRESSURE (SEE ANSI/ASSE 1001-1982)

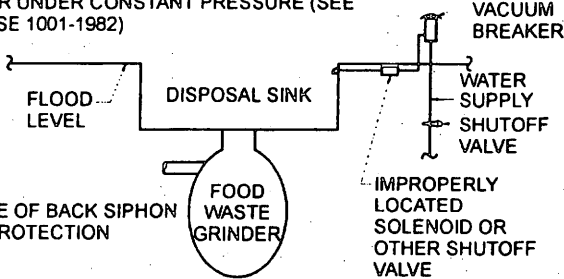

EXAMPLE OF BACK SIPHON PROTECTION

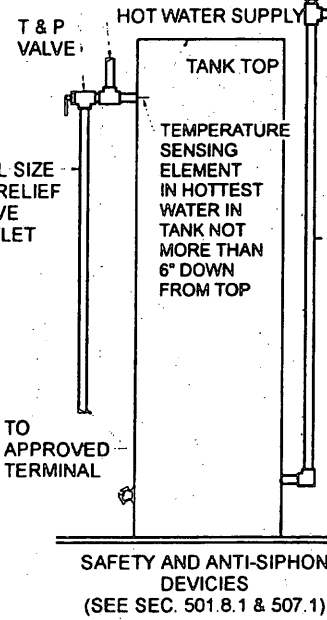

COLD WATER SUPPLY SHUTOFF VALVE MAXIMUM DISTANCE FROM HEATER 3'-0"

WHEN SEPARATE TEMPERATURE AND PRESSURE RELIEF VALVE ARE USED PRESSURE RELIEF VALVE MAY BE LOCATED IN THE COLD WATER SUPPLY BETWEEN SHUTOFF VALVE AND TANK OR HEATER

Figure 10

DANGER NO PROTECTION FROM BACK FLOW

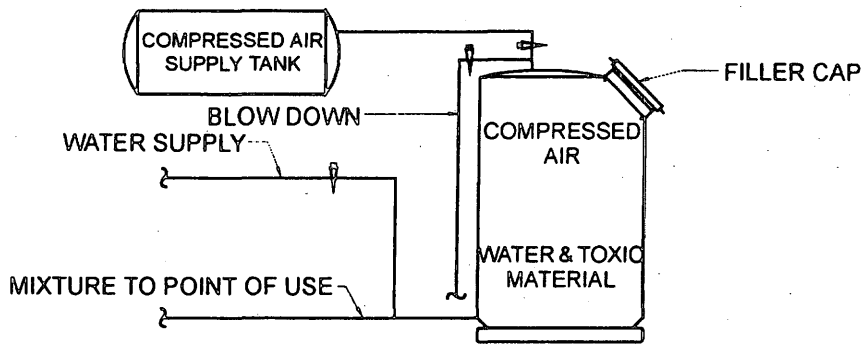

DANGER INADEQUATE PROTECTION FROM BACK-FLOW

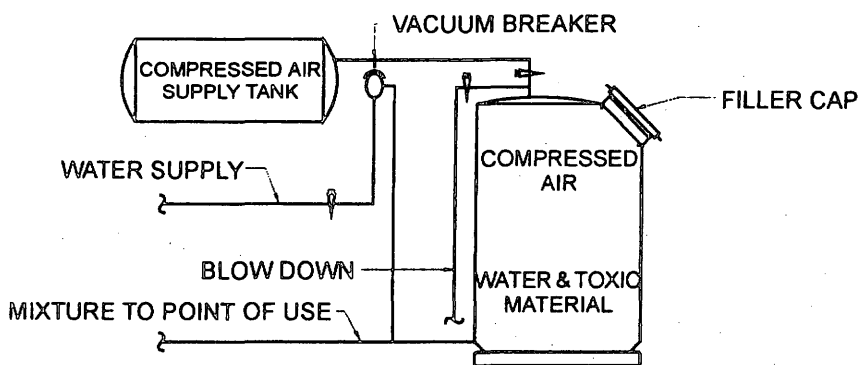

SAFE PROTECTED FROM BACK-FLOW

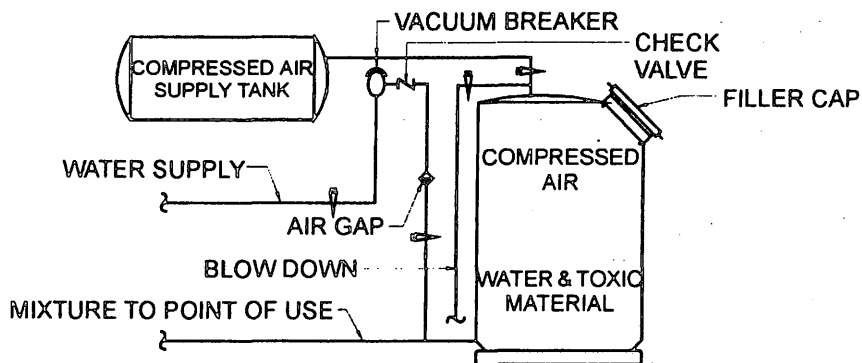

HIGH PRESSURE UNITS SUCH AS USED IN CAR WASHERS TO SUPPLY WATER & DETERGENT TO WHEEL WASH & OTHER UNITS UNDER HIGH PRESSURE

Figure 11

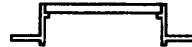
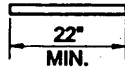

MANHOLE FRAME & COVER

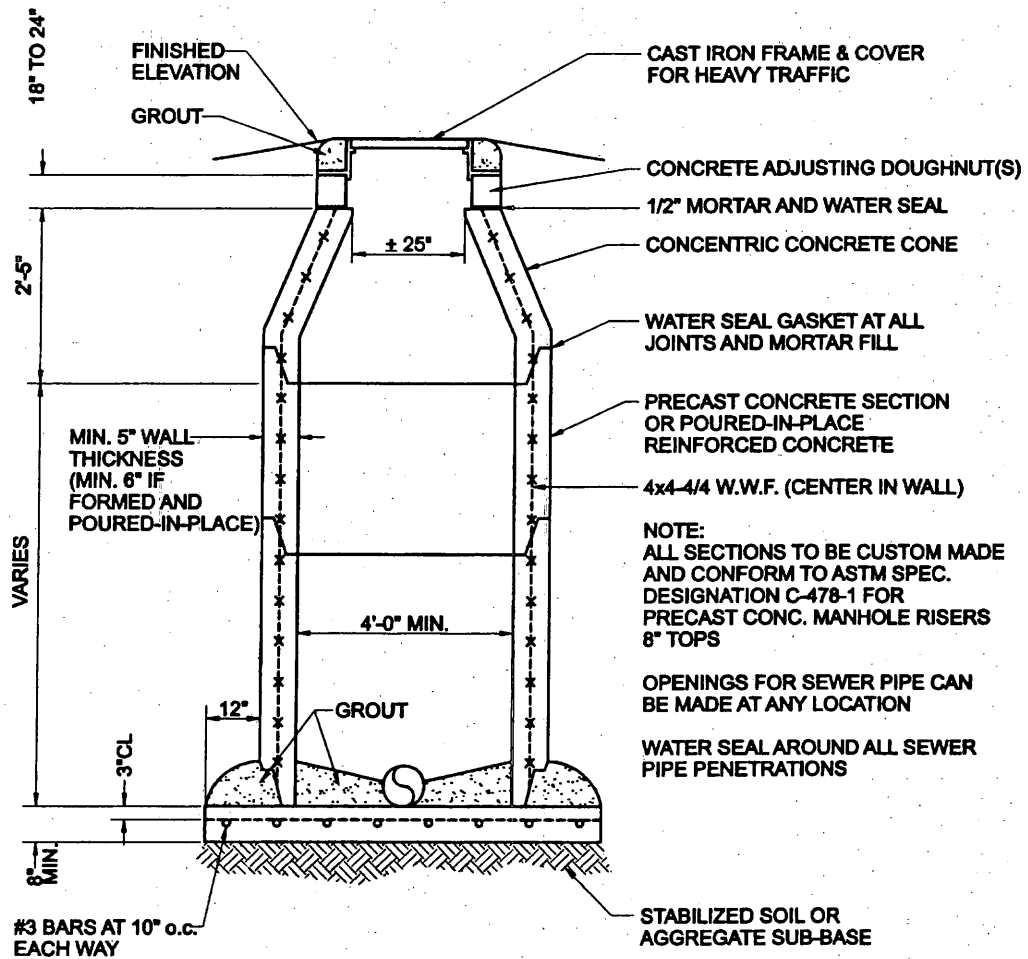

Typical Sewer Manhole
Figure 13

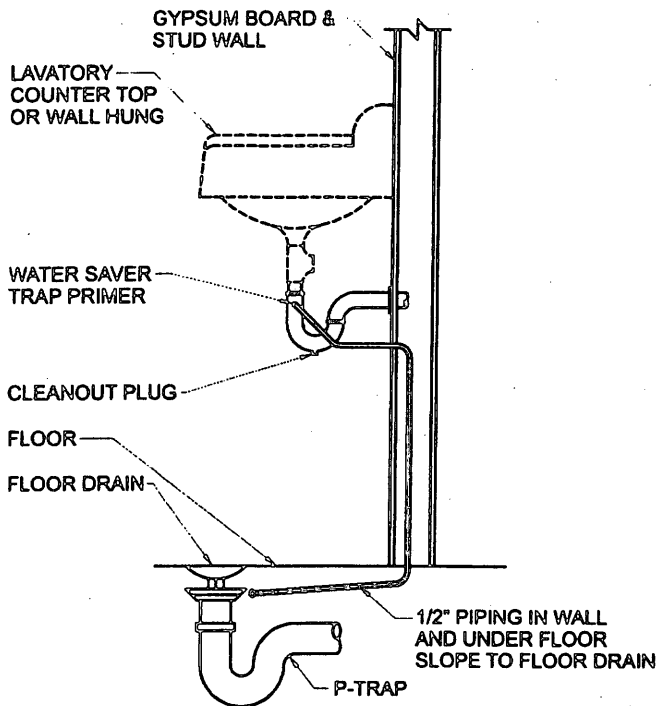

Floor Drain Trap Primer Detail
Figure 14

Alternate Formula For The Sizing Of Grease Traps

Number of Meals Per Peak Hour¹ x Waste Flow Rate² x Retention Time³ x Storage Factor⁴ = (liquid capacity)

1. Meals Served at Peak Hour
2. Waste Flow Rate
 - a. With dishwashing machine 6 gallon (22.7 L) flow
 - b. Without dishwashing machine 5 gallon (18.9 L) flow
 - c. Single service kitchen 2 gallon (7.6 L) flow
 - d. Food waste disposer 1 gallon (3.8 L) flow
3. Retention Times
 - Commercial kitchen waste dishwasher 2.5 hours
 - Single service kitchen single serving 1.5 hours
4. Storage Factors
 - Fully equipped commercial kitchen 8 hour operation: 1
 16 hour operation: 2
 24 hour operation: 3
 - Single Service Kitchen 1.5

Figure 15

APPENDIX K VACUUM DRAINAGE SYSTEMS

(APPENDIX K IS FOR INFORMATIONAL PURPOSES ONLY)

K101 SYSTEM

K101.1 General

Since a vacuum drainage system is considered an alternate designed plumbing system, the requirements of Chapter 12 shall apply.

K101.2 System Design

Vacuum drainage systems shall be designed in accordance with manufacturer's specifications. The system arrangement, including piping, tank assemblies, vacuum pump assembly and other components necessary for proper function of the system shall be in accordance with manufacturer's specifications.

K101.3 Plans and specifications

Plans and specifications for such systems shall be submitted to the State Health Officer for review and approval prior to installation.

K102 FIXTURES

Gravity type fixtures used in vacuum drainage systems shall comply with Chapter 4.

K103 DRAINAGE FIXTURE UNITS

The drainage fixture load of gravity drainage systems which discharge into or receive discharge from vacuum drainage systems shall be based upon values in Chapter 7.

K104 WATER SUPPLY FIXTURE UNITS

Water supply fixture load shall be based upon values in Chapter 6. The load requirement of a vacuum type water closet shall be determined per manufacturer's specifications.

K105 TRAPS AND CLEANOUTS

Gravity type fixtures shall be provided with traps and cleanouts in accordance with Chapters 7 and 10.

K106 MATERIALS

Vacuum drainage pipe, fitting and valve materials shall be as specified by the vacuum drainage system manufacturer and as listed in this Code.

K107 TESTS AND DEMONSTRATIONS

After completion of the entire system installation, the system shall be subjected to a vacuum test of 19 inches of mercury (64 kPa) and shall be operated to function as required by the State Health Officer and/or the local Plumbing Official and the man-

ufacturer. Tests shall be witnessed by the State Health Officer and/or the local Plumbing Official. The results of such tests shall be submitted to the State Health Officer and the local Plumbing Official.

K108 WRITTEN INSTRUCTIONS

Written instructions for the Operations, Maintenance, Safety and Emergency procedures shall be provided to the Building Owner and shall be available for inspection by the State Health Officer and the local Plumbing Official at any time.

APPENDIX L

ALTERNATE DESIGNED PLUMBING SYSTEMS

(APPENDIX L IS FOR INFORMATIONAL PURPOSES ONLY)

L101 GENERAL

L101.1 Scope

The provisions of this appendix shall govern the materials, design and installation of specially designed plumbing systems. These systems shall be designed by a Registered Professional Engineer.

L101.2 General System Provisions

Discharge pipe systems shall comprise the minimum of pipework necessary to carry away the foul water from the building quickly and quietly, with freedom from nuisance or risk of injury to health.

L102 DEFINITIONS

DISCHARGE PIPE - a pipe which conveys the discharges from plumbing fixtures or appliances.

DISCHARGE UNIT - a unit so chosen that the relative load-producing effect of plumbing fixtures can be expressed as multiples of that unit. The discharge unit rating of a fixture depends on its rate and duration of discharge and on the interval between discharges. It is not a simple multiple of a rate of flow and is a different method of assessment than the fixture unit applicable to other chapters of this code and the two (fixture unit and discharge unit) cannot be interchanged.

VENTILATING PIPE - a pipe provided to facilitate the circulation of air within the system and to protect trap seals from excessive pressure fluctuation.

L103 COMBINATION WASTE AND VENT SYSTEM

L103.1 Approval

Plans and specifications for each combination waste and vent system shall be submitted to the plumbing official, and approval shall be obtained before any installation is started.

L103.2 Limits

L103.2.1 A combination waste and vent system is limited to sinks, dishwashers, floor sinks, indirect waste receptors, floor drains or similar applications where the fixtures are not adjacent to walls or partitions. It consists of the installation of waste piping in which the trap of the fixture is not individually vented.

L103.2.2 Caution must be exercised to exclude appurtenances delivering large quantities of water or sewage such as pumps, etc., in a combination waste and vent system in order that adequate venting will be maintained.

L103.3 Dishwashers

Dishwashers and scullery sinks in commercial buildings shall drain through a grease interceptor sized in accordance

with this code and they shall discharge into a floor sink through a minimum air gap.

L103.4 General Design

L103.4.1 Every waste pipe and trap in this system shall be at least two pipe sizes larger than the size required in Chapter 7, and at least two pipe sizes larger than any fixture tail piece or connection, except that when "P" traps are installed above the floor, the "P" trap and horizontal fixture drain need not meet this requirement. The vertical waste pipe two sizes larger than the fixture outlet connection shall be extended above the floor to normal roughing height, and a cleanout shall be installed in top of the connecting waste tee. The fixture drain length shall be limited by Table 908.1. Floor sinks shall be connected through a running trap two pipe sizes larger than the sink outlet. Floor sink and waste piping from the floor sink to the trap shall be sized for the total fixture units draining thereto, based on Table 713.2, but in no case shall the line be less than 2-inch (51 mm) soil pipe when piping is underground.

L103.4.2 A vent shall be provided at the upstream end of each branch, washed over or under by the last fixture on the branch. No vent shall take off from the horizontal waste branch at an angle of less than 45 degrees (0.785 rad) from the horizontal unless washed by a fixture. A minimum size vent shall be located at all points where branches intersect. A vent shall be located downstream from all fixtures in the system, in addition to the upstream vent, separating this system from all other systems in the building. No fixtures other than those permitted in L104.2 shall discharge into any branch or portion of this system. (See Figure No. J6 and J7 of Appendix J.)

L103.4.3 Caution shall be used in the design of the system to assure that the vertical distance from fixture or drain outlet to trap weir does not exceed 24 inches (610 mm). Long runs shall be provided with additional relief vents located at intervals of not more than 100 ft (30.5 m) to equalize pressure in the system.

L103.5 Size of Vents

The size of vents shall be in accordance with requirements of 920.2 and Table 920.2, but the cross-sectional area shall be not less than one-half of the area of the waste pipe served, except that the vents shall be the same size as the waste branch to a point at least 6 inches (152 mm) above the flood level rim of the highest fixture connected before reduction, in accordance with Table 920.2.

L103.6 Receptor Drain Size

Indirect waste receptors shall be sized for the fixture units draining thereto, regardless of other requirements of this code.

L104 SINGLE STACK DISCHARGE AND VENTILATING SYSTEMS

L104.1 Approval

The purpose of this section is to make provisions for the design and installation of plumbing systems not otherwise in this code. The plumbing official shall require that necessary plans submitted under the section are signed by a Registered Professional Engineer.

L104.2 Tests

The single stack discharge and ventilating system shall be tested in accordance with 1203.3.

L104.3 General

L104.3.1 Trap Function. To prevent exchange of air between the discharge pipe system and the building, a trap having an adequate water seal shall be provided for each fixture (see L104.4). The discharge piping system shall be so designed as to retain adequate water seals in all traps under normal pressure fluctuations caused by discharge from fixtures (see 1203.3). For design purposes, the effects of the flow of water in the branch connecting the fixture to the stack, and the flow of water down the stack, shall be considered separately.

L104.3.2 Seal Loss (Branch Effect). Seal losses produced by flow in a branch depend on the following:

1. The design of the fixture (funnel shaped fixtures increase the chance of self-siphonage).
2. The length and fall (slope or gradient) and the diameter of the pipe. Branch effects are not affected by the height of the building and they can therefore be controlled by limiting the length and the fall of the branch.

L104.3.3 Seal Loss (Stack Effect)

L104.3.3.1 Seal losses produced by flow down the stack depend on the following:

1. The flow load (which depends on the number of fixtures connected to the stack and the frequency with which they are used).
2. The diameter of the stack.
3. The height of the stack.

L104.3.3.2 Excessive seal losses can be prevented by choosing a size of stack appropriate to the height of the building and to the number of fixtures connected to it.

L104.3.4 Fixture Layout. Where the layout of fixtures is suitable, careful design and installation can lead to considerable economies in pipework by eliminating the need for separate ventilating pipes (see L104.6). Where these requirements cannot be followed, traps shall be ventilated by pipes of adequate size as described in L104.7.

L104.3.5 System Design. Consideration shall be given in design to the following points which, in addition to being good general practice, will also obviate trouble from the foaming of detergents:

1. Where practicable, all fixtures shall be connected to one main stack which is at least 4 inches in diameter

except for one story buildings where a 3-inch stack may be satisfactory (see L104.6 and Table L104.5B).

2. Where sinks are connected to a separate stack, the stack shall be larger than normal (a minimum of 4-inch diameter for buildings over five stories) and connected directly to the building drain.
3. For over two sinks, stacks shall be (when one sink is over another on separate floor levels) a minimum of 2 1/2-inch diameter.
4. The interconnection of stacks is not permitted except when fixtures below such interconnection are vented as required elsewhere in this code.
5. For buildings more than five stories high, ground floor fixtures shall be connected separately to the building drain, and vented back into the main discharge stack above the fixtures on the floor above, or the vent shall be connected with a main ventilating stack when such stack is required by Table L104.6C.
6. Bends and offsets in vertical stacks are prohibited.

L104.3.6 Jointing and Support. The selection of materials, their jointing and support shall be in consideration of the effects of possible settlement, thermal movement and corrosion (see L104.9). Some materials may require protection against mechanical damage.

L104.3.7 Access. There shall be adequate provision for access to pipework, and the embedding of joints in the structure shall be avoided (see L104.8 and L104.10).

L104.4 Traps

L104.4.1 General. The entry of foul air from the drainage system into the building is prevented by the installation of suitable traps which are self-cleansing. A trap which is not an integral part of a fixture shall be attached to and immediately beneath the fixture outlet and the bore of the trap shall be smooth and uniform throughout.

L104.4.2 Diameters. The internal diameters of traps shall be not less than those given in Table L104.4.2.

Table L104.4.2
Minimum Internal Diameters of Traps

Type of Domestic Appliance	Min. Internal Diameter (in.)
Lavatory	1 1/4
Sink	1 1/2
Bathub	1 1/2 or 2 ¹
Shower	2
Wash tub	1 1/2
Kitchen waste disposal unit (tubular trap is essential)	1 1/2

1 in = 25.4 mm

Note:

1. See Figures L104.5A and L104.5B and Table L104.5A.

L104.4.3 Depth of Seals. Traps of water closets shall have a minimum water seal of 2 inches (51 mm); traps of other fixtures shall have a minimum water seal of 3 inches (76 mm)

for pipes up to and including 2 inches in diameter and 2-inch minimum water seal for pipes over 2 inches in diameter.

L104.5 Discharge Pipes

L104.5.1 Diameters. The internal diameter of a horizontal discharge pipe (fixture drain) shall normally be that of the trap to which it is attached, and in no case less, except that no fixture drain shall be less than 1 1/2-inch diameter.

L104.5.2 Branch Gradients. The fall of discharge pipes shall be adequate to drain the pipe efficiently and in no case less than shown in Table L104.5C (see L104.5.5).

L104.5.3 Bends, Branches and Offsets. All bends, branches and offsets shall be of easy radius and there shall be no restriction in the bore of the pipe.

L104.5.4 Prevention of Cross Flow. To prevent water closet discharge from backing up a bath waste line, the latter shall be connected to the stack with its center line either at, above, or at least 8 inches (203 mm) below the center line of the water closet branch (see Figure L104.5A). Where this cannot be achieved, a parallel branch may be used (see Figure L104.5B). Alternatively, the level of the water closet branch connection may be modified as above by dotted lines in Figure L104.5B.

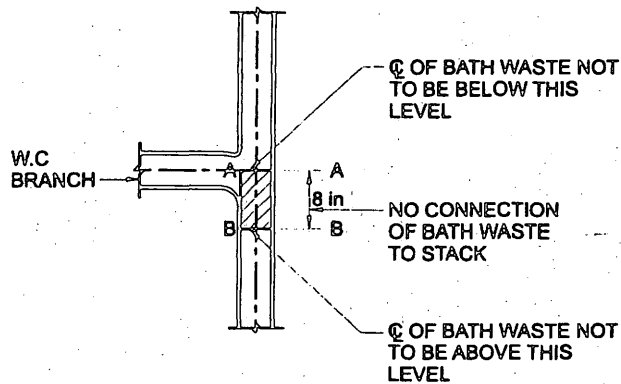
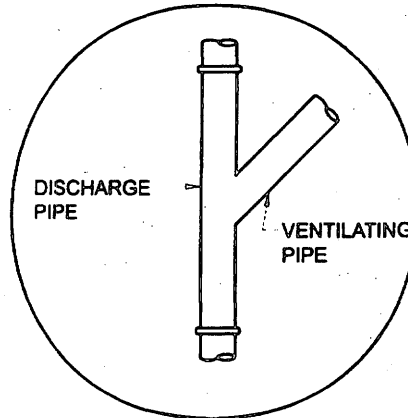
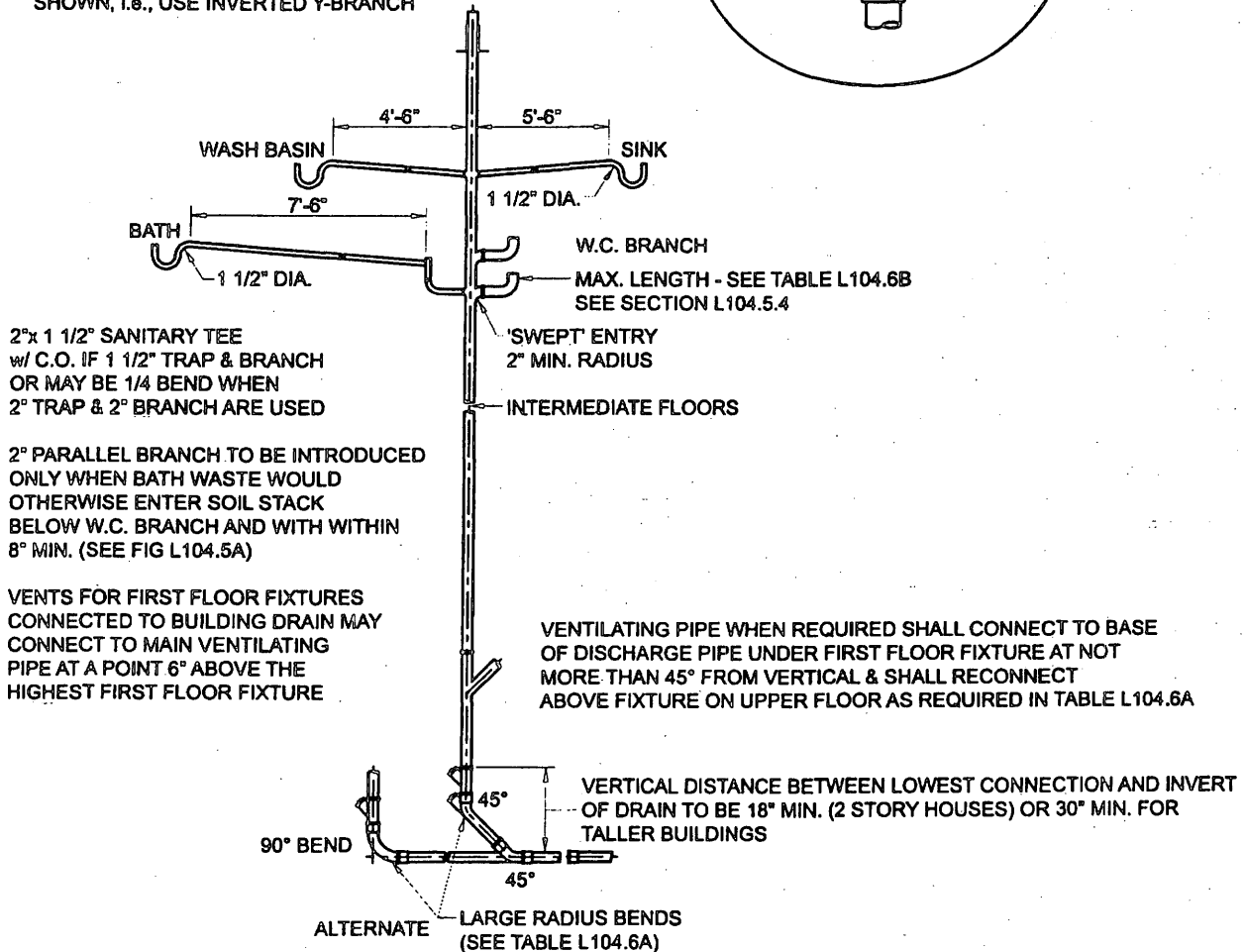

Figure L104.5A
Connections of Bath Waste to Stack

VENTILATION PIPES CONNECTING TO THE DISCHARGE STACK AT INTERMEDIATE LEVELS SHALL CONNECT IN A DOWNWARD DIRECTION 45° FROM THE VERTICAL



ON TOP FLOOR ONLY ABOVE HIGHEST FIXTURE BRANCH VENT FITTING TO BE REVERSE OF THAT SHOWN, i.e., USE INVERTED Y-BRANCH



1. FOR DEPTH OF TRAP SEALS SEE SECTION L104.4
2. NO OFFSETS ARE PERMITTED BELOW THE CONNECTION OF THE TOPMOST FITTING OF THE STACK.
3. FALL OF BRANCH DISCHARGE PIPE VARIES WITH LENGTH.

Figure L104.5B
Main Features of Single Stack System

L104.5.5 Pipe Capacities. Discharge unit values for plumbing fixtures are given in Table L104.5A. For other fixtures the discharge unit value shall be taken as that given in Table L104.5A for a fixture with the same diameter trap with a comparable use interval. Where other intervals are expected, the appropriate discharge unit value may be determined since the values given in Table L104.5A show that the discharge unit value is inversely proportional to the use interval, i.e., if the interval is doubled, then the discharge unit value is halved. The discharge unit values of all fixtures contributing to flow in a pipe shall be added and the appropriate pipe size (and fall) chosen from Table L104.5B for vertical stacks or Table L104.5C for the building drain or its horizontal branches.

L104.5.6 Waste Disposal Units. Special precautions are necessary where kitchen or food waste disposal units are connected to the discharge pipe system. The discharge pipe from such a unit shall connect directly to the main discharge pipe without intermediate connection with any other discharge pipe. Tubular traps shall always be used and any instructions as to installation given by the manufacturer shall be observed. To avoid hot grease being carried into discharge pipes and drains, where it might build up and cause blockage, waste disposal units shall always be automatically flushed with cold water in order to solidify grease before it enters the drainage system.

Table L104.5A
Plumbing Fixture Discharge Unit Values

Type Fixture	Intervals between use in minutes	Discharge unit values
Tank Type W.C.	20	15
Sink	25	8
Wash Basin	25	3
Bathtub	75	8
Shower Stall	75	4
Garbage Disposal	25	4
1 fixture group consisting of 1 W.C., 1 Sink, 1 Tub and 1 Lavatory		20

Table L104.5B
Maximum Number of Discharge Units Allowed on Vertical Stacks^{1, 2}

Nominal Internal Diameter of Pipe (in.)	Discharge Units
2	20 (No W.C.)
3	200 (No W.C.)
4	850
5	2700
6	6500

1 in = 25.4 mm

Notes:

1. The capacity of a vertical discharge pipe (stack) is limited by the need to preserve a large air core to prevent excessive pressure fluctuation. The flow capacity of a stack may therefore be less than that of a pipe of the same diameter laid at a steep fall.
2. Discharge pipes sized by this method give the minimum size necessary to carry the expected flow load. Separate ventilation pipes may be required (see L104.7). It may be worthwhile to consider oversizing the discharge pipes to reduce the ventilating pipework required.

Table L104.5C
Maximum Number of Discharge Units Connected to Building Drain or Building Sewer^{1, 2}

Nominal Internal Diameter of pipe (in.)	Fall Per Foot (in.)		
	1/8	1/4	1/2
2	—	10	26
3	40	100	230
4	30	430	1,050
5	780	1,500	3,000
6	2,000	3,500	7,500

1 in = 25.4 mm

Notes:

1. Discharge pipes sized by this method give the minimum size necessary to carry the expected flow load. Separate ventilation pipes may be required (see L104.7). It may be worthwhile to consider oversizing the discharge pipes to reduce the ventilating pipework required.
2. Building sewer sizes start at 4 inches.

L104.6 Design of Pipe Systems for Dwellings

L104.6.1 General. In dwellings only, the choice and layout of fixtures and their waste pipes may follow the recommendations for simplified systems as provided in this section. Simplified systems for other types of buildings may be possible but are not provided for in this code.

L104.6.2 Design of Single Branches and Fittings

L104.6.2.1 Branch discharge waste pipes (fixture drains) serving plumbing fixtures shall have a uniform shallow fall and the inlet to the stack shall be of a sanitary pattern and have a sweep of not less than 1 inch (25.4 mm) radius. Any horizontal change of direction in a fixture drain shall be of long radius and vertical changes of direction are prohibited.

L104.6.2.2 Water closet branch inlets to the stack shall be swept in the direction of flow with a radius at the invert of not less than 2 inches (51 mm). Entries at 45 degrees (0.785 rad) from the vertical are considered equivalent.

L104.6.2.3 Detailed provisions for the design of single fixture branch pipes (fixture drains) and fittings are given in Table L104.6A and Table L104.6B.

Table L104.6A
Design of Single Branches and Fittings

Component	Design Requirements	Possible Problem
Bend at foot of stack	Bend to be of "large radius", <i>i.e.</i> , 6-inch minimum root radius or, if adequate vertical distance is available, two "large radius" 45 bends are to be preferred. Vertical distance between lowest branch connection and invert of drain to be at least 18 inches for a two story house and 30 inches for taller dwellings. Where this distance cannot be achieved, ground floor fixtures shall be connected directly to the building drain and vented as provided for in other chapters of this code. See Figure L104.5B.	Back pressure at lowest branch, foaming of detergents
W.C. branch connection to stack	Water closet connections shall be swept in the direction of flow with radius at the invert of not less than 2 inches. Fittings in other materials shall have the same sweep as cast iron fittings. The length of unvented water closet is closet branches shall be limited by the diameter of the branch piping: 6 ft for 3-inch diameter, 10 ft for 4-inch diameter.	Induced siphonage at lower level in the stack when water closet is discharged
Lavatory waste 1 ¹ / ₄ -inch trap and 1 ¹ / ₂ -inch minimum waste pipe. Lavatories with 1 ¹ / ₂ -inch P.O. plugs may be installed as provided for sink waste.	"P" traps shall be used. The maximum fall of the waste pipe shall not exceed the hydraulic gradient of the pipe. For the maximum distance between the stack and trap weir see Table L104.5B. Any bends on plan shall be of not less than 3-inch radius at the center line. Waste pipes longer than the recommended maximum length shall be vented. As an alternative, 2 inch diameter waste pipes may be used so long as the hydraulic gradient is not exceeded, but additional maintenance may be necessary to maintain the bore.	Self-siphonage
Bath waste 1 ¹ / ₂ -in. trap and 1 ¹ / ₂ -in. waste pipe	"P" traps shall be used (a 2-inch parallel branch, when required shall not be considered a violation of requirements of other sections of this code, when its vertical length does not exceed 12 ¹ / ₂ inches, and the center line of the parallel branch is not more than 12 ¹ / ₂ inches from the stack). Owing to the flat bottom of a bath, the trailing discharge normally refills the trap and the risk of self-siphonage is much reduced. Waste pipes 7 ft 6 in. long at a fall of 1/4 in./ft have been used successfully. Position of entry of bath waste into stack to be as shown in Figure L104.5A.	Self-siphonage
Sink Waste 1 ¹ / ₂ -in trap and 1 ¹ / ₂ -in waste pipe	"P" traps shall be used. Owing to the flat bottom of a sink, the trailing discharge normally refills the trap and the risk of self-siphonage is much reduced. Fall of 1/4 in./ft shall be maintained. For maximum length, see Table L104.5B. A sink with 1 ¹ / ₂ -inch tail piece may be drained with 2-inch horizontal branch not exceeding 8 feet in length. When a 2-inch branch is used, the trap outlet shall connect to a 2 x 1 ¹ / ₂ inches reducing fitting. An opening into the branch larger than 1 ¹ / ₂ inches will not be permitted except for a cleanout.	Self-siphonage

1 in = 25.4 mm

Note:

Where the length or fall of the discharge pipe serving a waste fixture is greater than the recommended maximum in this table, the discharge pipe shall preferably be vented (see L104.7) or a larger diameter discharge pipe shall be used. This may have a maximum length of 10 ft.

Table L104.6B
Distance From Trap Weir to Stack or
Other Ventilating Pipe

Size of Fixture ¹ Drain (in.)	Distance Trap to Stack or Vent
Note 4	4 ft 6 in.
1 1/2	5 ft 6 in. ²
2	7 ft 6 in. ³

1 in = 25.4 mm

Notes:

1. Minimum size.
2. Other than bath waste.
3. For bathtubs see Table L104.6A.
4. 1 1/2-inch fixture drains required for lavatories with 1 1/4-inch traps.

L104.6.3 Design of Main Pipework

L104.6.3.1 Design details for stacks of various diameters are given below. The choice of design will depend on the space taken up by the pipes and the ease with which they can be accommodated in the building.

L104.6.3.2 An offset in the stack above the topmost connection to the stack has little effect on the performance of the system. Offsets below the topmost connection should be avoided lest extra ventilating pipes be necessary to maintain adequate water seals.

L104.6.4 3-Inch Stacks. 3-inch stacks in a single stack system are limited to fixtures other than water closets and to fixtures with maximum drain sizes of 2 inches.

L104.6.5 4-Inch Stacks. For details of ventilating pipes see Table L104.6C.

L104.6.6 5-Inch Stacks with No Vents (Single Stack System). Suitable for buildings up to 12 stories high where the stack serves one group of fixtures on each floor, or up to 10 stories high where the stack serves up to two groups of fixtures on each floor.

L104.6.7 6-Inch Stacks with No Vents (Single Stack System). Suitable for buildings up to at least 20 stories high with not more than two groups of fixtures on each floor.

Table L104.6C
Ventilating Pipes Required for Various Loading Conditions
4-inch Discharge Stack

Number of stories	Stack serving one group ¹ on each floor	Stack serving two groups ¹ on each floor
Flats ² , 1 to 5	No separate venting required	No separate venting required
6-11	2-inch vent stack connected to the discharge stack on alternate floors	2-inch vent stack connected to the discharge stack on alternate floors
12-15	2-inch vent stack connected to the discharge stack on each floor	2-inch vent stack connected to the discharge stack on each floor
16-20	2 1/2-inch vent stack connected to the discharge stack on each floor	3-inch vent stack connected to the discharge stack on each floor
Maisonettes ³ , 1 to 4	Single stack system	Single stack system
5-8	Single stack system	2-inch vent stack connected to the discharge stack on alternate (bathroom) floors
9-15	2-inch vent stack connected to the discharge stack on alternate (bathroom) floors	2-inch vent stack connected to the discharge stack on alternate (bathroom) floors
16-20	2 1/2-inch vent stack connected to the discharge stack on alternate (bathroom) floors	3-inch vent stack connected to the discharge stack on alternate (bathroom) floors

1 in = 25.4 mm

Notes:

1. Each group consists of a water closet, a bath, a basin and a sink. Where dwellings contain more fixtures it may be necessary to provide additional vents.
2. Each complete living unit is on one floor.
3. Each complete living unit occupies space on two floors, with baths on one floor of the unit.

L104.7 Ventilating Pipes

L104.7.1 General. The purpose of a ventilating pipe is to maintain equilibrium of pressure within the system and thus prevent the destruction of trap seals by siphonage or compression. It will also assist in preventing undue accumulation of foul air by facilitating air movement in the pipe system.

L104.7.2 Installation. Ventilating pipes shall be so installed that there is a continuous fall back into the discharge pipe system to prevent any possibility of a waterlock preventing free movement of air through the ventilating system and to minimize the risk of internal corrosion. Short turn fittings in the pipework shall be avoided.

L104.7.3 Branch Vents. Branch ventilating pipes may be connected to a main ventilating pipe or be carried upward either individually or in combination with one another. Such connections shall be above the flood level of the highest fixture served.

L104.7.4 Sizes. The diameter of a branch ventilating pipe or of a ventilating stack shall be as given in Table L104.7. For extremely long ventilating stacks, a larger diameter pipe shall be used. (See Table L104.7, Note 1.)

L104.7.5 Arrangement. Branch ventilating pipe when required shall be connected to the individual fixture discharge pipe (fixture drain) not less than 3 inches (76 mm) from the crown weir of the trap. A fixture may be connected to the bottom of a fixture vent, or at the base of a main ventilating stack to assure its being kept clear.

L104.7.6 Purpose. The purpose of the ventilating pipes is to reduce the pressure fluctuations in the discharge stack by allowing air to enter the stack. Where venting is necessary, therefore, it is often convenient to do so by cross connecting the ventilating stack and the discharge stack directly, preferably above the highest fixtures as appropriate. To prevent cross flow into the ventilating stack, the branch ventilating pipe shall slope upward from the discharge stack at an angle of not less than 45 degrees (0.785 rad) until it reaches a point 6 inches (152 mm) above the flood level of the highest fixture serving the floor, at which point it may run at a horizontal angle until connecting with the vertical vent.

Table L104.7

Branch Ventilation Pipe or Ventilating Stack

Diameter of branch discharge pipe or discharge stack, D (in.)	Diameter of ventilating pipe ¹
Smaller than 3	$\frac{2}{3} D$
3 to 4 inclusive	2 in.
Larger than 4	$\frac{1}{2} D$

1 in. = 25.4 mm

Notes:

1. When the vent length exceeds the length of the discharge stack, the vent shall be at least one pipe size larger than required in Table L104.7 except for individual fixture vents.

L104.7.7 Discharge Point. The outlet of every ventilating pipe system to the open air shall be at such a height and position as will effectively prevent the entry of foul air into the building (see 905).

L104.8 Pipe Chases and Enclosures, Etc.

Pipework enclosures, e.g., ducts, casings, etc., shall be of adequate size and shall have access provisions for maintenance, painting, testing and cleaning. They shall be constructed appropriately for fire resistance in accordance with requirements of the Standard Building Code.

L104.9 Choice of Materials

Materials shall conform to the applicable requirements of other sections and chapters of this code. Fittings used in the construction of single stack plumbing systems shall in no case be designed with inlet radii less than provided for in this section.

L104.10 Access to Interior of Pipework

Sufficient access shall be provided to enable all pipework to be tested and to provide reasonable access for cleaning and other necessary maintenance. All access points for clearing purposes shall be carefully sited to allow the entry of clearing apparatus or the insertion of testing apparatus and, where these are in ducts, consideration shall be given to the other services accommodated in the duct.

L104.11 Simultaneous Discharge

L104.11.1 The system of discharge pipes shall be capable of withstanding satisfactorily the effects of the probable maximum simultaneous discharge of fixtures which will occur in practice. The number of fixtures to be discharged together to simulate this effect is given in Table L104.11.

L104.11.2 For example, for a block of flats nine stories high with the stack serving one water closet, one lavatory, one sink and one bath of each floor, the test discharge is one water closet, one lavatory and one sink discharged simultaneously. Where the stack serves two water closets, two lavatories and two sinks on each floor, the test discharge is one water closet, one lavatory and two sinks. For the purpose of this test, baths are ignored as their use is spread over a period and consequently they do not add materially to the normal peak flow on which Table L104.11 is based. Where a stack serves baths only, the number to be discharged simultaneously in a discharge should be taken to be the same as for sinks.

L104.11.3 All traps shall be fully charged and the appropriate combination of fixtures discharged simultaneously. Trap seals shall be measured at the end of the discharge. The worst conditions occur when fixtures on the upper floor are discharged. A reasonable test, therefore, would be to discharge up to one water closet, one lavatory and one sink from the top of the building, distributing any additional fixtures along the stack.

**Table L104.11
Number of Fixtures to be Discharged
Simultaneously for Testing Stability of Trap Seals**

Number of fixtures of each kind on the stack	Water Closet	Wash Basin	Kitchen Sink	Misc. (ea. type) ²
1-9	1	1	1	1
10-18	1	1	2	2
19-26	2	2	3	3
27-50	2	3	3	3
51-78	3	4	4	4
79-100	3	5	5	4

Notes:

1. When the miscellaneous fixture is a washer drain, omit one sink from test for each washer drain, except when washers only are connected to the stack.
2. For washing machine drains (no washers connected) test shall be conducted with hoses connected to both the hot and cold water supply outlets and with outlets fully opened. (This is in lieu of discharge from washers.) Test should be of 5 minutes duration, one-half of one cup of liquid detergent shall be dispensed into the washer drain pipe at approximately one-third cup per minute along with the water during the last 3 minutes of each test.

L105 SINGLE STACK PLUMBING SYSTEM

L105.1 Approval

The plumbing official shall require that necessary plans submitted under this section are signed by a Registered Professional Engineer.

L105.2 Tests

The single stack discharge and ventilating system shall be tested in accordance with 1203.3.

L105.3 Solvent Single Stack Plumbing System

Design and installation shall be in accordance with design criteria contained in CDA Handbook No. 402/0. Materials shall meet standards and specifications listed in Table 703 for drain, waste and vent pipe and fittings.

L106 APPENDIX REFERENCES

Additional provisions for Alternate Designed Systems are contained in Appendix J - Illustrations. These provisions are applicable only where specifically included in the body of the code sections or in the adopting ordinance.

APPENDIX M

PROCEDURES FOR DESIGN, CONSTRUCTION AND INSTALLATION OF INTERCEPTORS AND SEPARATORS

(APPENDIX M IS A REQUIREMENT OF THIS CODE)

M101 GENERAL

The provisions of this appendix shall apply to the design, construction, installation and testing of interceptors and separators required in accordance with 1004.

M102 DEFINITIONS

Definitions contained in Chapter 2 shall also apply to this appendix except where the following special definitions shall apply:

BOTTLING PLANT SEPARATOR - an interceptor designed to separate and retain broken glass and other solids.

GREASE INTERCEPTOR - an interceptor of less than 125 gallon capacity which is designed and installed so as to separate and retain grease and which is generally installed indoors entirely above grade.

GREASE TRAP - an interceptor of at least 125 gallon capacity which is designed and installed so as to separate and retain grease and which is generally installed below grade outdoors with provisions for above grade accessibility for cleaning purposes.

LAUNDRY TRAP - an interceptor designed to separate and retain lint, strings, rags, buttons or other similar materials which may be discharged from laundries.

OIL SEPARATOR - an interceptor designed to separate and retain waste oil and other petroleum products.

SAND INTERCEPTOR - an interceptor designed to separate and retain sand, gritty material or other types of heavy solids.

SLAUGHTER HOUSE SEPARATOR - an interceptor designed to separate and retain feathers, entrails and other similar substances.

SPECIAL TYPE SEPARATOR - an interceptor designed to separate and retain deleterious, hazardous or undesirable matter from normal wastes for proper disposal, rendering, or recycling.

M103 GENERAL REGULATIONS

M103.1 Size and Type

The size and type of each interceptor or separator shall be determined according to maximum volume and rate of discharge and shall be approved by the Plumbing Official.

M103.2 Location

The location of each interceptor or separator shall be approved by the Plumbing Official.

M103.3 Prior Approval

No interceptor or separator shall be installed until its design, size, location and venting has been approved by the Plumbing Official.

M103.4 Cleanout on Discharge Line

A two-way cleanout shall be provided on the discharge line immediately downstream of all interceptors.

M103.5 Grease Traps/Grease Interceptors

M103.5.1 Grease traps will be required in all instances of new construction or substantial renovation of buildings or facilities. In addition, a grease trap will be required for existing buildings or facilities when a proper installation can be performed without the need to break up a concrete slab.

M103.5.2 At the discretion of the Plumbing Official, grease interceptors may be allowed when the conditions for a grease trap installation do not exist or cannot easily be met [e.g., (1) new construction or substantial renovation of buildings or facilities is not being performed and a concrete slab would have to be broken at the existing building or facility for the proper installation of a grease trap, (2) an outside, unpaved area surrounding the building where a grease trap could be installed is available; however, it is determined that the area is too far away from the plumbing fixtures that the grease trap would be servicing, or (3) the installation of a grease trap is unfeasible such as when servicing a kitchen which is located on the upper floors of a multistoried building].

M104 GREASE TRAPS

M104.1 In accord with M103.5.1, an approved type grease trap complying with provisions of this section shall be installed in the waste line leading from sinks, drains and other fixtures or equipment in establishments such as restaurants; cafes; lunch counters; cafeterias; bars and clubs; hotels; hospitals; sanitariums; factory, school or day care center kitchens; markets; or other establishments where grease may be introduced into the drainage or sewage system in quantities that can affect line stoppage or hinder sewage treatment or private sewage disposal, except when, in the opinion of the Plumbing Official, they are not necessary.

M104.2 Minimum Capacity

M104.2.1 General

A grease trap should be designed to be large enough to allow the water contained within it to remain cold since only cold water separates grease. In addition, a grease trap should be designed to be large enough so that it requires cleaning at a frequency no more often than once per month.

M104.2.2 Without Garbage Grinder

The minimum capacity for applications without a garbage grinder shall not be less than 125 gallons below the static water level. This capacity is sufficient to hold the flow from one meal long enough to accomplish proper grease separation when serving up to 50 people. When over 50 people are served, a proportionately larger grease trap shall be provided based upon 2¹/₂ gallons per person.

M104.2.3 With Garbage Grinder

When a garbage grinder is connected (see 1004.11.1), the grease trap shall have a minimum capacity of no less than 500 gallons below the static water level. This capacity is sufficient to hold the flow from one meal long enough to accomplish proper grease separation when serving up to 50 people. When over 50 people are served, the minimum grease trap capacity shall be increased beyond 500 gallons based upon at least 2¹/₂ gallons per person.

M104.2.4 Alternate Sizing Formula

For informational purposes only, an alternate sizing formula may be found in Appendix J.

M104.3 If a grease trap must be installed within an enclosed building, any access covers shall be gasketed to prevent the intrusion of odors into the building.

M104.4 A one compartment grease trap is acceptable; however, a two compartment, or a one compartment grease trap with a baffle wall between the inlet and outlet, is preferred.

M104.5 The grease trap shall be placed as close to the plumbing fixture(s) discharging greasy waste as possible, but preferably on the outside of the building when feasible.

M104.6 The minimum diameter of the outlet pipe shall not be less than four inches.

M104.7 A minimum of one foot of air space shall be provided above the static water level.

M104.8 Venting

M104.8.1 The grease trap outlet shall be properly vented to prevent the trap from siphoning itself out. Any internally vented outlet line shall have the vent terminal extended to within two inches of the bottom of the access cover to prevent grease from escaping the grease trap through the open vent terminal.

M104.8.2 For those grease traps having a gasketed cover, the grease trap outlet line shall not be allowed to be inter-

nally vented. In this case, the outlet line itself shall have a two inch vent pipe properly installed.

M104.9 The invert of the grease trap outlet opening, at the point where water exits the grease trap, shall be located at a maximum of six inches and a minimum of four inches from the floor of the grease trap. This requirement also applies to any intermediate outlets in multi-compartment grease traps. The invert of the inlet shall be at least three inches above the invert of the outlet.

M104.10 On unbaffled single compartment grease traps, a 90° ell shall be used on the inlet and shall terminate six inches below the static water level. On baffled single compartment grease traps, a baffle wall shall be placed between the inlet and outlet. The inlet shall discharge into the grease trap at a level at least six inches below the top of the baffle wall. The baffle wall shall extend from two inches below the static water level to the bottom of the grease trap such that incoming water will have to overflow above the top of the baffle wall in order to reach the outlet.

M104.11 The horizontal distance between the inlet and outlet piping in the grease trap should be sufficient to allow gravity-differential separation to the grease so that it will not escape through the outlet. The minimum horizontal distance shall be twenty-four inches.

M104.12 Access/Covers

M104.12.1 Access from the top of the grease trap shall be provided by an easily removable cover above an access opening of at least twenty inches square or twenty-four inches round. Additional access opening/covers shall be provided as necessary to provide accessibility to each compartment in multi-compartment or multi-baffled arrangements as well as access to both the inlet and outlet. Access opening covers shall be above or at grade to provide ready accessibility.

M104.12.2 Each access cover shall be designed so that it cannot slide, rotate, or flip when properly installed in order that the opening is not unintentionally exposed. (The intention is that a child-resistant cover be provided. Especially for lightweight covers, mechanical fasteners are recommended to augment the safety of and ensure positive closure of the cover.)

M104.13 No water jacketed grease trap shall be approved or installed.

M104.14 Each grease trap shall have an approved water seal of not less than 2 inches in depth or the diameter of its outlet, whichever is greater.

M104.15 Abandoned grease traps shall be pumped and filled as required for abandoned septic tanks in accord with Chapter XIII (Sewage Disposal), Appendix A, section 1.22 of the State of Louisiana Sanitary Code.

NOTE:
IF 3" THIMBLE IS USED AS ILLUSTRATED,
ONE 2" LOCAL VENT MAY BE ELIMINATED

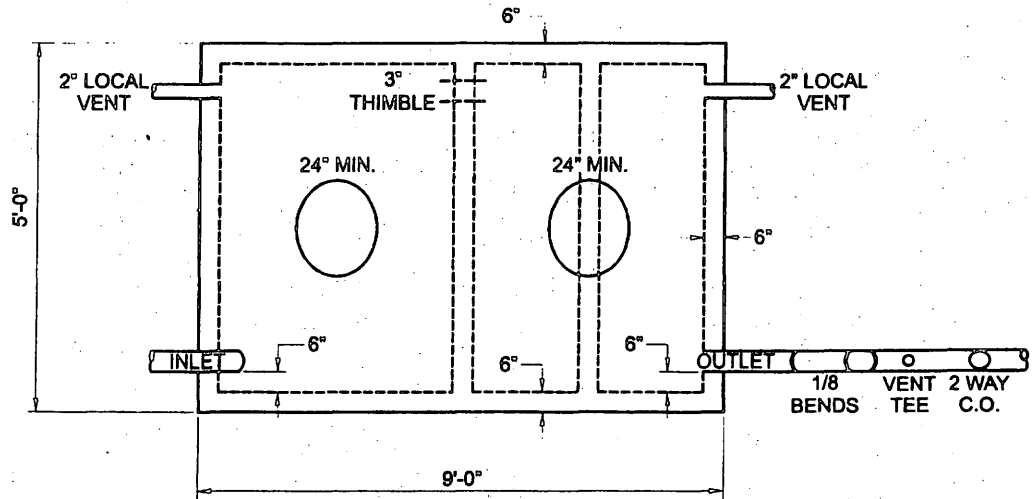

Grease Trap (top view)
Figure M104.A (1 of 2)

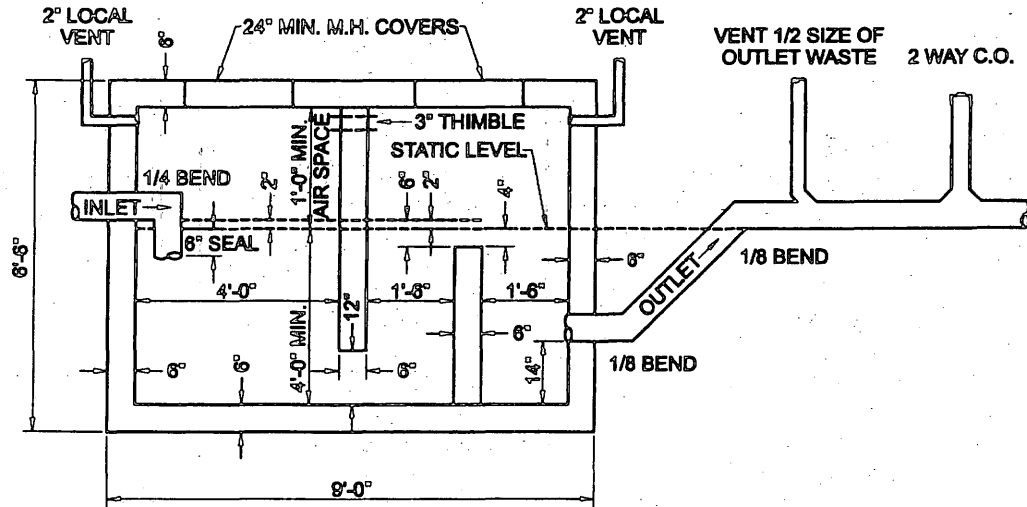

Grease Trap (side view)
Figure M104.A (2 of 2)

NEED EASILY REMOVABLE COVERS-
 AT LEAST 20" SQUARE OR 24" ROUND.
 TOP OF GREASE TRAP AT OR
 ABOVE GRADE.

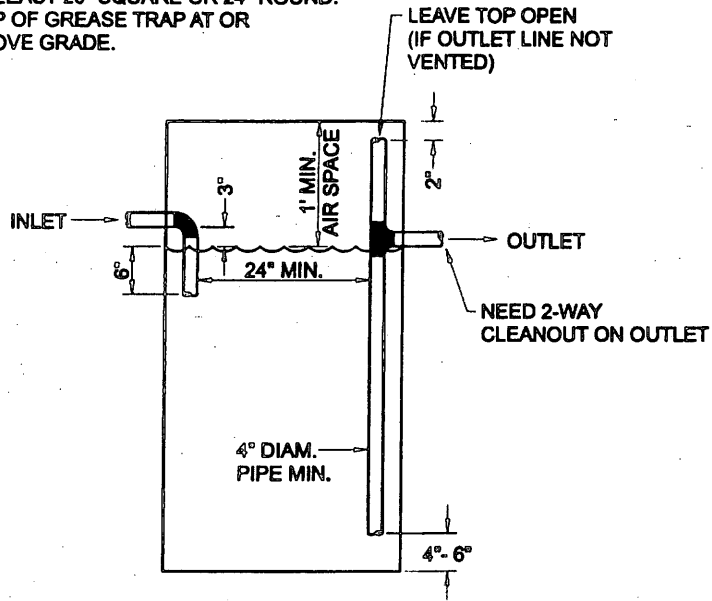

Min. volume below invert of outlet = 125 gallons

= 2' x 2' x 4' water depth
 (would have to be built
 2' x 2' x 5' in order to
 give 1' air space above
 water line)

or = 2' x 3' x 3' water depth*
 (would have to be built
 2' x 3' x 4' in order to
 give 1' air space above
 water line)

(* This would be preferred in order
 to keep inlet & outlet at least 24"
 apart from each other.)

Grease Trap (sanitary details only)
Figure M104.B

GREASE TRAP

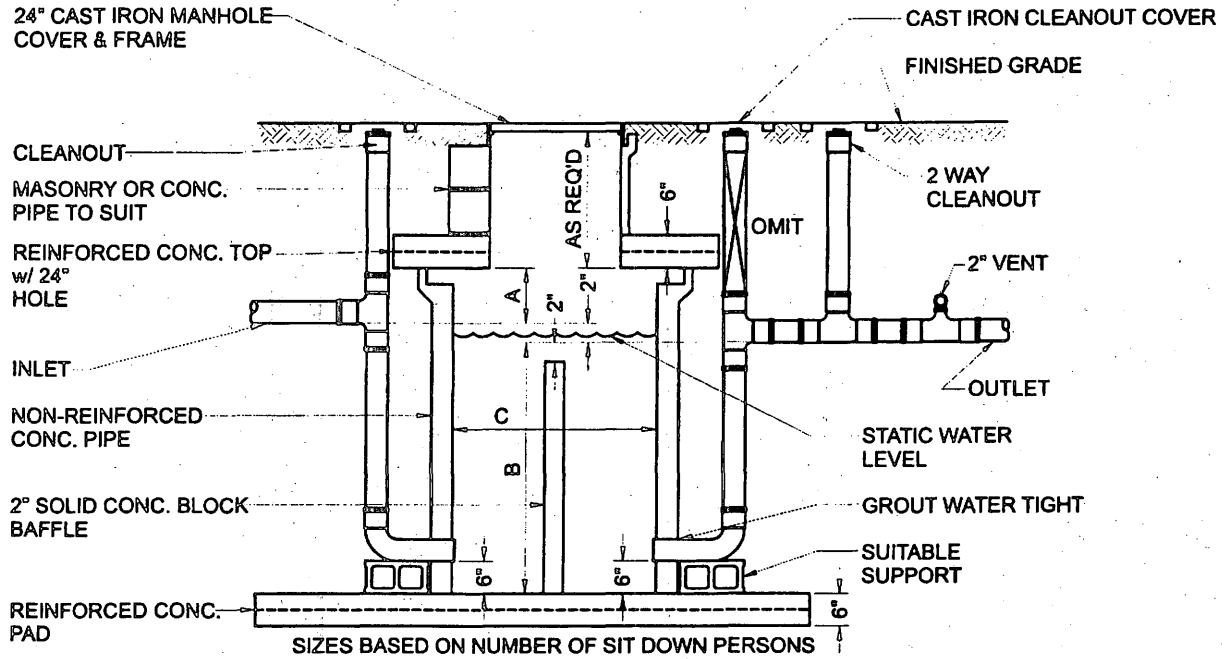

INTERCEPTOR	DIM. A	DIM. B	DIM. C	
SIZE 1	12"	36"	36"	3 x 3 x 3 = 63 PEO
SIZE 2	12"	36"	48"	4 x 4 x 3 = 113 PEO
SIZE 3	12"	60"	60"	5 x 5 x 5 = 294 PEO

NOTES:

1. THE BOTTOM OF THE INLET PIPE SHALL BE NOT LESS THAN 2 INCHES ABOVE THE BOTTOM OF THE OUTLET PIPE.
2. THE BOTTOM OF THE OUTLET PIPE SHALL BE 2 INCHES ABOVE THE TOP OF THE BAFFLE WALL.
3. TRAP INDICATED ABOVE IS FOR CONCRETE PIPE CONSTRUCTION. ALTERNATE MATERIAL AND METHODS OF INSTALLATION MUST BE SUBMITTED FOR APPROVAL PRIOR TO INSTALLATION.

RECTANGULAR
 3 x 3 x 3 = 81 PEOPLE
 4 x 4 x 3 = 164 PEOPLE
 5 x 5 x 5 = 375 PEOPLE

**Grease Trap
 Figure M104.C**

M105 GREASE INTERCEPTORS

M105.1 If allowed by the Plumbing Official pursuant to M103.5.2, an approved type grease interceptor complying with PDI-G101 and the provisions of this section may be installed in the waste line leading from sinks, drains and other fixtures or equipment in establishments such as restaurants; cafes; lunch counters; cafeterias; bars and clubs; hotels; hospitals; sanitariums; factory, school or day care center kitchens; markets; or other establishments where grease may be introduced into the drainage or sewage system in quantities that can affect line stoppage or hinder sewage treatment or private sewage disposal, except when, in the opinion of the Plumbing Official, they are not necessary.

M105.2 No grease interceptor shall be installed which has an approved rate of flow of less than 20 gallons per minute, except when specially approved by the Plumbing Official.

M105.3 Each plumbing fixture or piece of equipment connected to a grease interceptor shall be provided with an approved type flow control or restricting device installed in a readily accessible and visible location in the tailpiece or drain outlet of each such fixture. Flow control devices shall be so designed that the flow through such device or devices shall at no time be greater than the rated capacity of the grease interceptors. No flow control device having adjustable or removable parts shall be approved.

M105.4 Each grease interceptor required by this section shall have an approved rate of flow which is not less than that given in Table M105 for the total number of connected fixtures. The total capacity in gallons of fixtures discharging into any such grease trap shall not exceed $2\frac{1}{2}$ times the certified gallon per minute (gpm) flow rate of the grease interceptors as per Table M105.

Any grease interceptor installed with the inlet more than 4 feet lower in elevation than the outlet of any fixture discharging into such grease trap shall have an approved rate of flow which is not less than 50% greater than that given in Table M105.

For the purpose of this section, the term "fixture" shall mean and include each plumbing fixture, appliance, apparatus or other equipment required to be connected to or discharge into a grease interceptor by any provision of this section.

M105.5 Each fixture discharging into a grease interceptor shall be trapped and vented in an approved manner. An approved type grease interceptor may be used as a fixture trap for a single fixture when the horizontal distance between the fixture outlet and the grease interceptor does not exceed 4 feet and the vertical tailpipe or drain does not exceed $2\frac{1}{2}$ feet.

M105.6 Grease interceptors shall be maintained in efficient operating condition by periodic removal of the accumulated grease. No such collected grease shall be introduced into any drainage piping or public or private sewer.

M105.7 Each grease interceptor shall have an approved water seal of not less than 2 inches in depth or the diameter of its outlet, whichever is greater.

M105.8 When grease interceptors are allowed to be installed by the Plumbing Official in commercial kitchens, a recommended sizing criteria on is provided in Table M105.

Table M105
Grease Interceptors

Required Rate of Flow Per Minute, Gallons	Grease Retention Capacity, Pounds
20	40
25	50
35	70
50	100

Procedure for Sizing Grease Interceptors

Steps	Formula	Example
1	Determine cubic content of fixture by multiplying length x width x depth.	A sink 48" long by 24" wide by 12" deep. Cubic content $48 \times 24 \times 12 = 13,824$ cubic inches
2	Determine capacity in gallons. 1 gal = 231 cubic inches.	Contents in gallons $\frac{13,824}{231} = 59.8$ gallons
3	Determine actual drainage load. The fixture is normally filled to about 75% of capacity with water. The items being washed displace about 25% of the fixture content, thus actual drainage load = 75% of fixture capacity.	Actual drainage load $0.75 \times 59.8 = 44.9$ gallons
4	Determine flow rate and drainage period. In general, good practices dictate a 1-minute drainage period; however, where conditions permit, a 2-minute drainage period is acceptable. Drainage period is the actual time required to completely drain the fixture. Actual Drainage Flow rate = $\frac{\text{Load}}{\text{Drainage period}}$	Calculate flow rate for one-minute period $\frac{44.9}{1} = 44.9$ gpm Flow Rate Two-minute period $\frac{44.9}{2} = 22.5$ gpm Flow Rate
5	Select interceptor which corresponds to the flow rate calculated. Note: Select next larger size when flow rate falls between two sizes listed.	For one-minute period—44.9 gpm requires PDI size "50." For two-minute period—22.5 gpm requires PDI size "25."

Figure M105.A

M106 OIL SEPARATORS

M106.1 All repair garages and gasoline stations with grease racks or grease pits, and all factories which have oily wastes as a result of manufacturing, storage, maintenance, repair, or testing processes shall be provided with an oil separator which shall be connected to all necessary floor drains. The separation of vapor compartment shall be independently vented to the outer air. If two or more separation or vapor compartments are used, each shall be vented to the outer air or may connect to a header which is installed at a minimum of six inches above the spill line of the lowest floor drain and vented independently to the outer air. The minimum size of a flammable vapor vent shall not be less than two inches, and when vented through a sidewall, the vent shall not be less than ten feet above the adjacent level at an approved location. The interceptor shall be vented on the sewer side and shall not connect to a flammable vapor vent. All oil interceptors shall be provided with gastight cleanout covers which shall be readily accessible. The waste line shall not be less than three inches in diameter with a full-size two-way cleanout to grade. When an interceptor is provided with an overflow, it shall be provided with an overflow line (not less than two inches in diameter) to an approved waste oil tank having a minimum capacity of 550 gallons and meeting the requirements of the appropriate authority. The waste oil from the separator shall flow by gravity or shall be pumped to a higher elevation by an automatic pump. Pumps shall be adequately sized and accessible. Waste oil tanks shall have a two inch minimum pump-out connection at grade and

a 1½ inch minimum vent to atmosphere at an approved location at least ten feet above grade.

M106.2 Each manufactured interceptor that is rated shall be stamped or labeled by the manufacturer with an indication of its full discharge rate in gallons per minute (gpm). The full discharge rate to such an interceptor shall be determined at full flow. Each interceptor shall be rated equal to or greater than the incoming flow and shall be provided with an overflow line to an underground tank.

Interceptors not rated by the manufacturer shall have a depth of not less than two feet below the invert of the discharge drain. The outlet opening shall have not less than an 18 inch water seal and shall have a minimum capacity as follows: where not more than 3 motor vehicles are serviced and/or stored, interceptors shall have minimum capacity of 6 cubic feet, and one cubic foot of capacity shall be added for each vehicle up to ten vehicles. Above ten vehicles, the Plumbing Official shall determine the size of the interceptor required. Where vehicles are serviced only and not stored, interceptor capacity shall be based on a net capacity of 1 cubic foot for each one hundred square feet of surface to be drained into the interceptor, with a minimum of six cubic feet.

M106.3 A combination oil and sand interceptor may be installed when the design is approved in writing by the Plumbing Official.

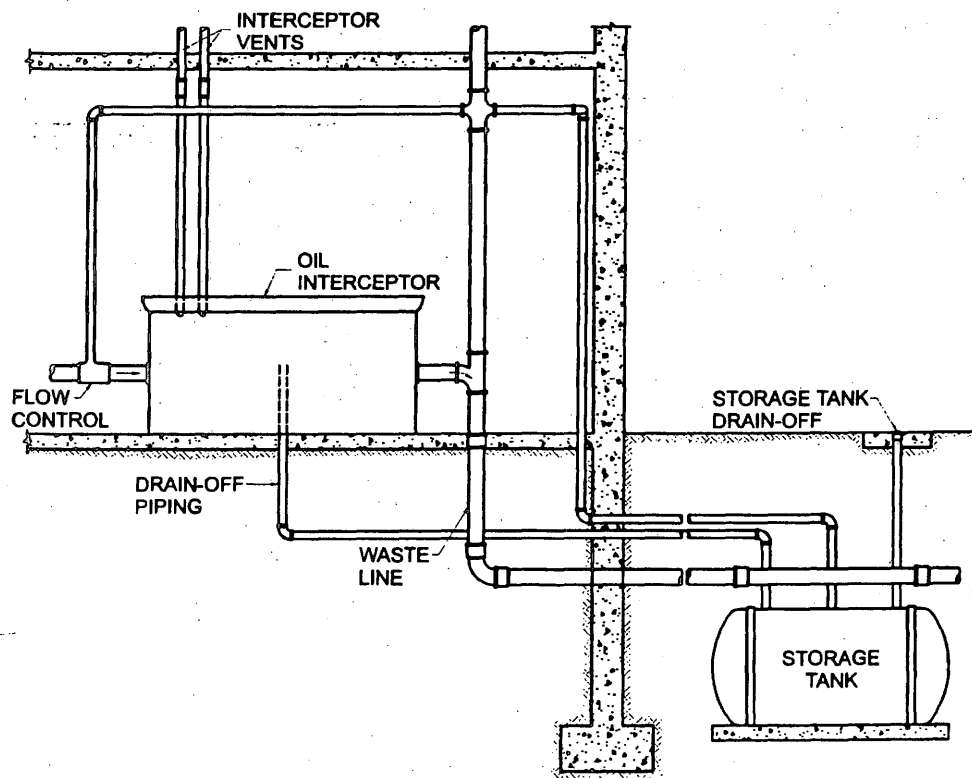
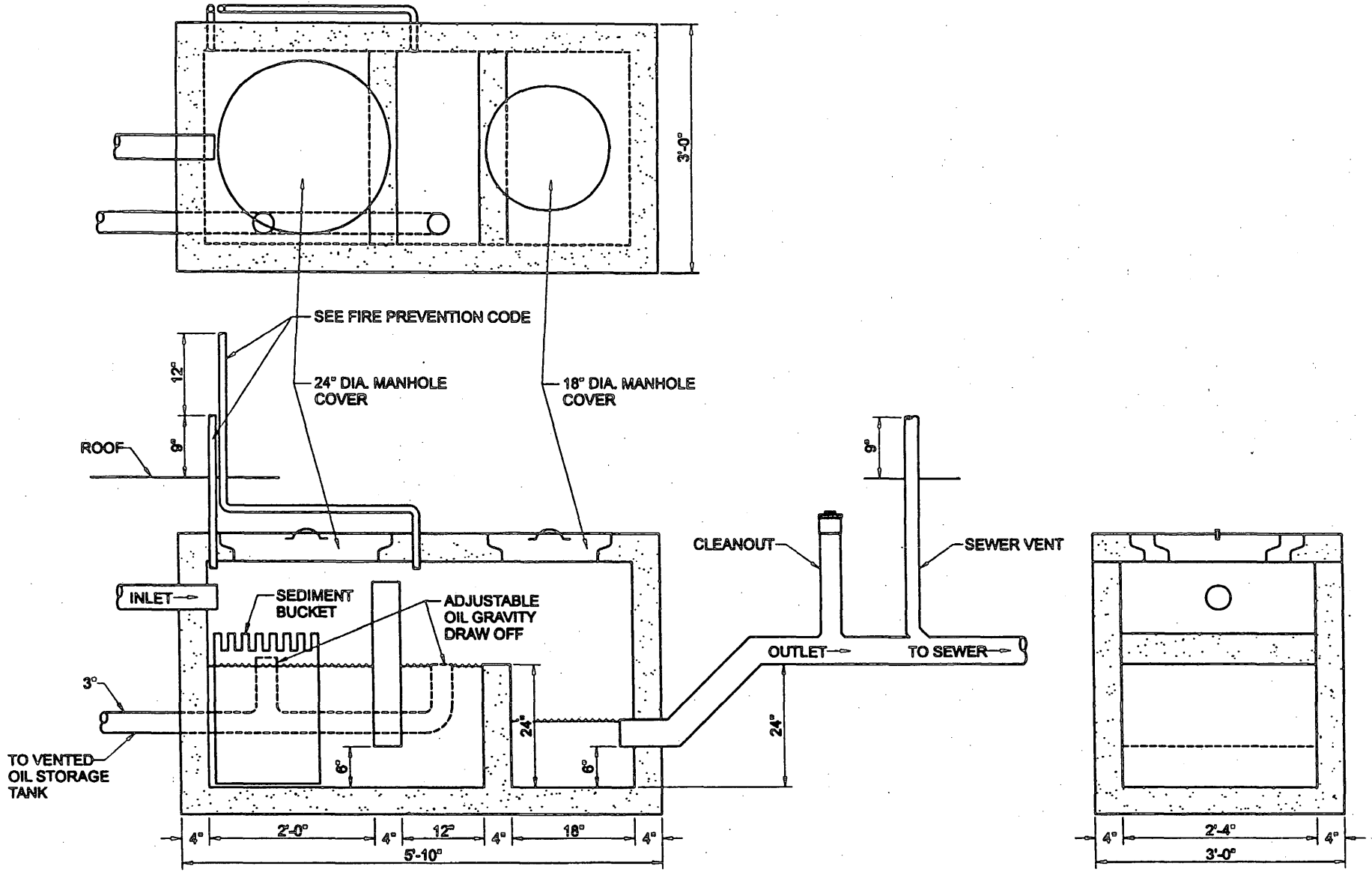

Figure M106.A

Oil Interceptor Details
Figure M106.B



M107 SAND INTERCEPTORS

M107.1 Multiple floor drains may discharge into one sand interceptor.

M107.2 Sand interceptors shall be built of brick or concrete, prefabricated coated steel, or other watertight material. The interceptor shall have an interior baffle for full separation of the interceptor into two sections. The outlet pipe shall be the same size as the inlet, the minimum being three inches, and the baffle shall have two openings of the same diameter as the outlet pipe and at the same invert as the outlet pipe. These openings shall be staggered so that there cannot be a straight line flow between any inlet pipe and the outlet pipe. The invert of the inlet pipe shall be no lower than the invert of the outlet pipe.

The sand interceptor shall have a minimum dimension of two feet square for the net free opening of the inlet screen and a minimum depth under the invert of the outlet pipe of two feet.

For each five gallons per minute flow or fraction thereof over 20 gallons per minute, the area of the sand interceptor inlet section is to be increased by one square foot. The outlet section shall at all times have a minimum area of 50 percent of the inlet sections.

The outlet section shall be covered by a solid removable cover set flush with the finished floor, and the inlet section shall have an open grating set flush with the finished floor and suitable for the traffic in the area in which it is located.

M107.3 Sand and similar interceptors for every solid shall be so designed and located as to be readily accessible for cleaning, shall have a water seal of not less than six inches, and shall be vented.

M107.4 Alternate designs for construction or baffling of sand interceptors complying with the intent of this code may be submitted to the Plumbing Official for approval.

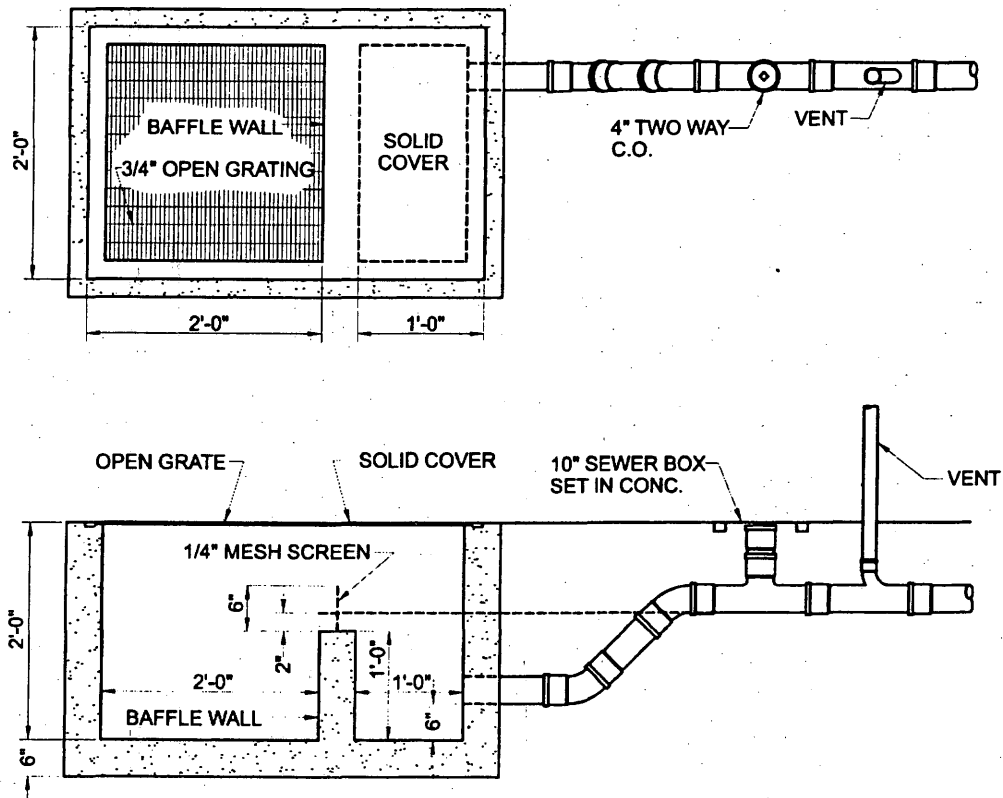

Sand Interceptor
Figure M107.A

M108 LAUNDRY TRAPS

Laundry equipment that does not have integral strainers shall discharge into an interceptor having a wire basket or similar device that is removable for cleaning and that will prevent passage into the drainage system of solids $\frac{1}{2}$ inch or larger in maximum dimension, such as string, rags, buttons or other solid materials detrimental to the drainage system.

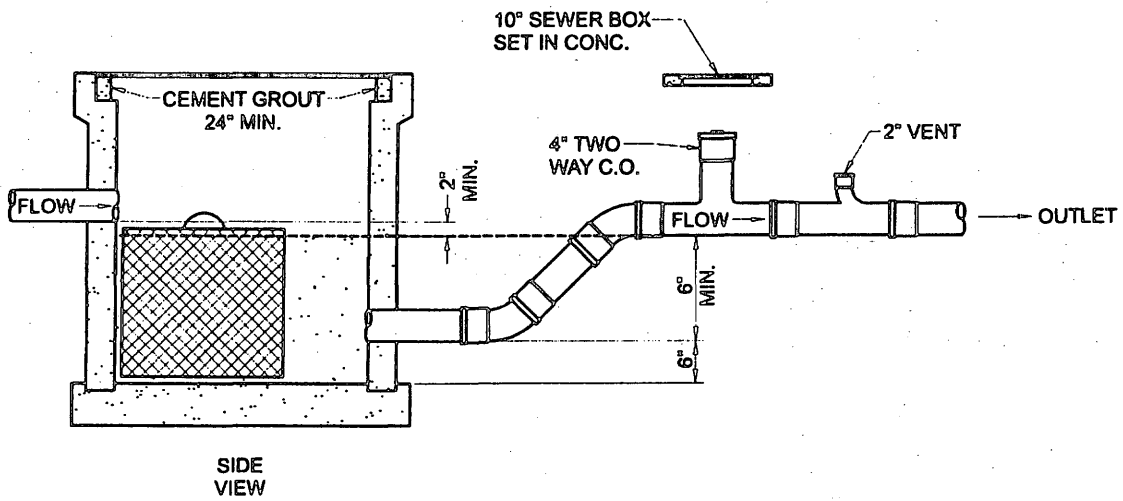
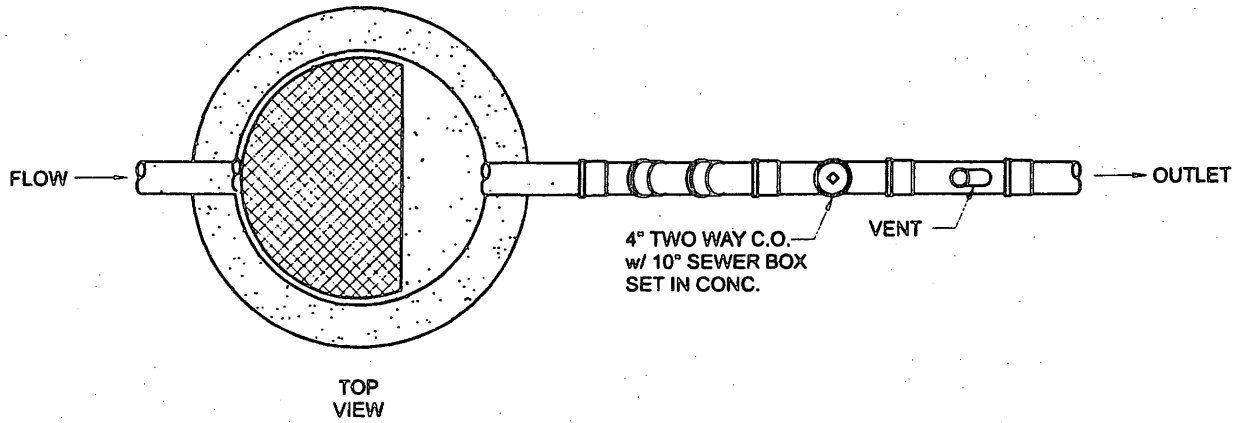

Lint Trap (with Non-Corrode Basket)
Figure M108.A

M109 BOTTLING SEPARATORS

Bottling plants shall discharge their process waste water into an interceptor which will provide for the separation of broken glass or other solids before discharging into the drainage system.

M110 SLAUGHTER HOUSE SEPARATORS

Slaughtering room drains shall be equipped with separators which shall prevent the discharge into the drainage system of feathers, entrails and other materials likely to clog the drainage system.

M111 SPECIAL TYPE SEPARATORS

M111.1 Wholesale Food Processing Establishments

Every fish, fowl and animal slaughter house or establishment and every fish, fowl and meat packing or curing establishment and every soap factory, tallow rendering, fat rendering and hide curing establishment, or any other establishment from which considerable amounts of grease are likely to be discharged into any plumbing system, sewer system, or private sewage disposal system, shall be connected to and shall drain or discharge into a grease trap approved by the Plumbing Official for this use.

M111.2 Other Special Applications

Interceptors or separators for other special type applications shall not be installed until their design, size, location and venting have been approved by the Plumbing Official.

INDEX

- Abandoned grease traps, M104.15
- Above ground piping, 303.8.4, 611.2, 703.3, 903.3, 1103.1
- Accessibility, backwater valves, 704.7.5
 - cleanout plugs, 710.3, 710.4, 710.5
 - expansion joints, 309.6
 - floor drains, 1001.4
 - interceptor, 1004.8
 - single stack system, L104.8, L104.10
 - slip joints, 401.5.2, 401.5.3
 - water heaters, 501.7
- Acid, soil & waste piping,
 - 304.1, 308.5, 409.4, 703.6, 706.6
 - system vent, 903.6
- Administration, Chapter 1
 - enforcement, 102.1, 102.3
 - fees, Appendix H
 - inspections and tests, 104, 311, 311.6, 1203, B108.14, C107.6, D108
 - permits, 102.4, 103
 - severability, 106
- Air break (drainage system),
 - defined, 202 indirect waste, 806.2
- Air chamber, 607.8
- Air gap (drainage system),
 - defined, 202 indirect waste, 806.1
- Air gap (water distribution)
 - defined, 202, D102,
 - cross connection control, 606.1, D103
- Air lock, B102
- Alterations and repairs, 301.5
- Alternate designed plumbing systems, Chapter 12
- Alternate materials and methods, 102.7
- Anchors, hangers and supports, 310
- Anti-siphon devices, 507.1
- Approved, defined, 202
- Approved materials, 405, 717.9
- Area drain, defined, 202
- Asbestos cement pipe, 1101.5
- Attachment, hangers and anchors, 310
 - horizontal piping, 310.5
 - vertical piping, 310.2
- Automatic flush valves, 409.13.5
- Automatic flushing tank, 409.11.1
- Auxiliary pressure, supplementary tank, 607.5
- Back-siphonage, 202, Appendix D
- Back-to-back fixtures, 914.3
- Backfill, material, Appendix I
 - trenching and excavation, 305
- Backfilling, 305.4
- Backflow, 606.1, Appendix D
 - air gap preventer for, 606, Appendix D
 - cross connection, defined, 202, D102
 - defined, 202, D102
 - preventer, 202, 606, D102
- Backwater valve, 1101.5,
 - 1101.8, 704.7, 409.4.1.3
- Bar and soda fountain sink traps, 907
- Baskets and strainers, 807.1.2, 409.3, M108
- Bathrooms, venting for double, 911.2
 - venting for multistory groups, 911.3
 - venting for one, 912
 - venting for single groups, 911.1
- Battery fixtures, defined, 202
- Battery venting, 914.1, 920.3, Table 920.3
- Boiler blow-off, defined, 202
- Borosilicate glass pipe and fittings,
 - 303.7.6, 310.2.7, 310.3.7
- Bottling plants, 1004.10.2
- Branch, defined, 202
 - fixture, 202, 1112.1
 - gradients, single stack systems, 922.5.2
 - horizontal, 202, 913.1
 - interval, defined, 202
 - vent, defined, 202
- Brazed joints, 612.4
- Brazing or welding, 309.4
- Building, defined, 202
 - other than dwelling, 610.4
 - storm sewer, 202, 1103.4
 - subdrain, 202, 1101.5
 - trap (house), defined, 202
- Building drain system, Chapter 7
 - above-ground piping within building, 703.3
 - below sewers, 717.1
 - defined, 202
 - materials, 703
 - piping in raceways or tunnels, 703.3
 - sizing, 714
 - underground piping within Buildings, 703.4
- Building sewer, 704
 - cleanouts, 704.5
 - defined, 202
 - materials, 703
 - sizing, 714
 - test, 311.4
- Building storm drains, defined, 202
 - size, Table 1108.2
 - underground, 1103.2
- Building classification, defined, 202
- Burned lead joints, 311.7
- Bushings, soldering, 303.7.4
- Calculation of size of water distribution system, 607
- Cast iron soil pipe, 303.7.1, 308.3, 707.3, 804
 - base support, 310.2.2
 - elastomeric compression gasket, 706.4
 - hangers 310.2.2, 310.3.2
 - joints, 309.1, 309.2
 - no-hub, 706.5
 - support intervals, 310.2.2
- Cast iron water pipe, 603, 608.1, 608.2, 611
- Caulked joints, 706.2
- Caulking ferrules, 303.7.3
- Cement mortar joints, 308.6
- Change in direction, 307.1
- Character of water, 601.9
- Circuit and loop venting, 914, 920.3, Table 920.3
- Circuit vent, 202, 920.3
- Circular-type sink, 409.7.1
- Clay pipe, 703, 1103.3
- Clay sewer pipe joints, 707.1
- Cleaning, indirect waste pipe, 805.2
 - plumbing fixtures, 403.1
- Cleanout, 303.7.6, 710.6, 710
 - accessibility, 710.4, 710.5
 - clearances, 712
 - size, 711
- Cleanouts on building sewers, 704.5
- Clear-water wastes, 807.2
- Clearances, cleanout, 712
- Close-coupled tanks, 409.13.4
- Code, remedial, 101.2

Color code, 605
 Combination waste & vent system,
 defined, 202, L103
 Combination compartment, defined, B102
 Combination fixture, defined, 202
 Combining storm with sanitary
 drainage, 1106.3
 Commercial, building grease traps/interceptors,
 1004.4, Appendix M
 dishwashing machine, 804.2
 grinders, 1004.11.1
 installations-interceptors, 1004, Appendix M
 type grinders-food wastes, 409.5.2
 Common vent, 202, 909, 909.2
 Concealed piping, 710.3
 Concrete sewer pipe, 703, 707.2
 Condemned equipment, 301.9
 Condensers and sumps, 807.3
 Conductor, defined, 202
 inside, 1103.1
 pipes prohibited, 1106.1
 protection of, 1106.2
 trap location, 1105.5
 Conductors and connections, 1106
 Connection, to plumbing system required, 301.11
 backflow, defined, 202, D102
 drainage system, 717.8
 fittings prohibited, 307.3
 indirect waste, 804.3
 plumbing fixtures, 408.4.2, 401.5.2
 sumps and ejectors, 717
 vent, 906, 914.2, 919
 water heater, 506, 601.10
 Continuous flow valves, 713.3
 Continuous vent, defined, 202
 Continuous waste, defined, 202
 Controls of water supply, 610
 Copper, DWV drainage tube, 703, 903
 sheet, 303.7.2
 tube, 310.2.4
 tubing to threaded pipe joints, 612.7.1
 tubing, 310.2.4, 310.3.4
 water tube, 603, 608, 611, 612.6
 Corrosion and breakage, 304.1
 Cross connection, 202, Appendix D
 Cross flow, prevention, single stack systems, L104.5.4
 Crown vent, 908.4
 Cutting or notching, 306.2

 Damage to drainage system or public sewer, 710.7
 Dead end, defined, 202
 Defective plumbing test, 311
 Definitions, Chapter 2, 302, 402, 502, 602,
 702, 802, 902, 1002, 1102
 for backflow control, D102
 for mobile homes, B102, C102
 Demand loads, 714
 Design, drinking fountains, 409.2.1
 plumbing fixtures, 408.4.1
 single stack systems, L104.3, L104.6, L105
 sumps and ejectors, 717
 Developed length, defined, 202
 Devices-energy shutoff, 507.4
 Direction of flow, 710.4
 Discharge, food waste grinders, 1004.11
 garbage can washers, 409.3
 single stack systems, L104.3
 Dishwashing machine, 409.1.1, 409.1.2
 commercial, 804.2
 protection, 409.1.1.1, 409.1.2.1
 separate trap for, 409.1.1.2, 409.1.2.2

Disinfection of potable water system piping, 601.8
 commercial, 606
 protection, 409.2.2, 606
 Disposal units, 409.5.1
 Distance, fixture trap from vent, Table 908.1
 trap to fixture, 1001.9
 trap to stack, single stack systems, Table L104.6B
 Distribution of water supply, 611
 Double bath, 911.2
 Double offset, defined, 202
 Double trapping, 1001.6
 Downspout or interior leader test, 311
 Downspout, defined, 202
 Drain and sewer combination, 1106.3
 Drain and sewers, building, 714.1
 Drain and water connections, 409.9.1
 Drain, 202, 609.7
 building below sewers, 717.1
 building, 202, Chapter 10
 cock, 614.1
 fixture, 202, 1003
 floor, 409.4, 717, 1106.4
 hose, B102, B110.2
 outlet, B102, B109.1
 roof, 202, 1107
 sediment, 501.5
 storm, 202, 1101.4
 Drainage, below sewer level, 301.1
 materials, 703, 1103, 1107.1
 pipe installations, 705
 required, storm, 1101.2
 requirements, 703.1
 system, defined, 202
 vent system test, 311
 Drainage piping, defined, 202
 offset, 715
 underground, 714.4
 Drainage system, sizing, 714
 Drainage system, Chapter 7
 building sewer, 704
 connections, 717.8
 determination of sizes, 714
 drainage piping installation, 705
 fittings or connections, 309, 707
 fixture units, 713
 floor drains, 717
 frost protection, 701.6
 materials, 703
 offsets in drainage piping, 715
 sumps and ejectors, 717
 unions, 1001.7
 Drains and storm sewers combined, 1106.3
 Drinking fountains, 409.2, 807.4
 design and construction, 409.2
 protection of water supply, 409.2.2
 Drips, 804.5
 Drum traps, 1003.4
 Duplex equipment, 717.5
 Durham system, defined, 202
 DWV copper drainage tube, 703, 903, 1103

 Effective opening, defined, 202
 Ejectors and sumps, 717
 Elastomeric compression gasket joints, 706.4
 Energy shutoff devices, 507.4
 Equipment, condemned, 301.9
 used or second hand, 301.8
 water heating, 401.2, Ch. 5
 water pumping and storage, 609
 Excavations, backfill and trenching, 305
 Existing buildings, 301.5.1, 101.4
 Existing work, defined, 202

Expansion joints, 309.6, 1101.4
 Extensions through wall, 905.6
 Exterior openings, 301.7.1

Fees, Appendix H
 Final test, 107, 311, 1203
 Fines, 102.1, 107
 Fittings, 307
 and sewer pipe, 303.8, 703
 drainage system, 703.5
 or connections prohibited, 709.2
 supply, 601.5
 vent, 903.5
 Fixture drain, defined, 202
 type and size, 1003
 Fixture outlets, and strainers, 408.3
 minimum pressure, 607.4
 Fixture overflow, 408.4
 Fixture trap, 1001.8
 distance to vent, 908.1
 vents for, 910
 Fixture unit, 202, 713
 flow rate, defined, 202
 per fixture or group, Table 713.1
 Fixtures and connections prohibited, 401.5
 Fixtures back-to-back, in battery, 914.3
 Fixtures, 401.5.1
 at different levels, 910.2
 branch, 202, 1112.1
 combination, defined, 202
 layouts, single stack systems, 1203
 not listed, Table 713.2
 plumbing, Chapter 4
 quality of, 405
 setting, 403.4
 supply size, 607.3
 values for, 713.1
 vents, 908
 Flag poling, 905.4
 Flared joints, 612.3
 Flashings for roof drains, 1107.4
 Flashings for vent terminals, 905.3
 Flat decks, 1107.3
 Float valves, 409.13.3
 Flood, level rim, defined, 202
 Floor drains, 409.4, 717
 must be trapped, 1106.4
 public restrooms, 409.4.1
 size, Table 713.1
 traps and strainers, 409.4.2
 Floor flanges, 303.7.5
 Flow, direction 710.4
 obstruction, 307.5
 Flush valve, defined, 202
 Flush valve-automatic, 409.13.5
 Flushing, device, 409.13.2
 tanks, automatic, 409.11.1
 Flushometer valve, defined, 202
 Food waste grinder units, 409.5
 commercial, 1004.11
 discharge, 1004.11
 Food grinder, 1004.11
 Food handling, 804.1
 Freezing, 304.4
 Frost, closure, 905.2
 protection, 701.6
 Frostproof closet, defined, 202
 Future fixtures, 714.3

Garbage can washers, 409.3
 Grade, 202, 906.1
 connections for vents, 906

Louisiana State Plumbing Code, 2000 edition[®]

horizontal drainage piping, 705.1
 Gravity and suction tanks, 609.8
 Grease interceptor, 1004, Appendix M
 defined, 202, Appendix M
 garbage can washer, 409.3
 Grease trap, defined, 202, Appendix M
 Grinders, commercial-type, 409.5.2
 food waste, commercial, 1004.11
 food waste, sinks waste outlets, 408.2
 food waste, units, 409.5
 Ground joint brass connections, 612.7.2

Hangers and anchors, 202, 310
 Hangers and supports, Chapter 3
 base of stacks, 310.5
 defined, 202
 general, 310.1
 horizontal piping, 310.3
 repair or replacement, 310.4
 strains and stresses, 310.1.1
 vertical piping, 310.2
 Header vent, 919
 Health and safety, 301.5.2
 Heel or side inlet bend, 307.4
 Historic buildings, 101.5
 Horizontal branch, 202, 913.1
 Horizontal drainage, piping, 705.1, 705.2, 705.3
 Horizontal fixture branches and stacks, Table 714.2
 Horizontal pipe, defined, 202
 Horizontal piping supports, 310.3.1
 Horizontal piping, 310.3
 Horizontal storm drain size, 1108.2
 Hospital plumbing systems, G101
 Hot water, distribution piping, 601.10
 for dishwasher, 409.1.3
 supply, 601.10
 House drain, defined, 202
 House sewer, defined, 202
 House trap, defined, 202
 Hydraulic gradient, 910.1

Identification, of materials, 303.4
 Identification, of piping, 605
 Improper location of piping and fixtures, 404.2
 Increases and reducers, 307.6
 Independent mobile home or travel trailer, B102
 Indirect waste pipe, 202, 804
 cleaning, 805.2
 connections, 804.3
 material and size, 803
 Indirect waste piping & special wastes, Chapter 8
 air break, 806
 air gap, 806
 backflow preventer, 806
 clear water wastes, 807.2
 condensers & sumps, 807.3
 drinking fountains, 807.4
 indirect waste piping, 804
 length, 805
 material & size, 803
 receptors, 807.1
 swimming pools, 807.5
 Individual conductor trap size, 1105.4
 Individual fixture venting, 913
 Individual or private sewage disposal system, 202, 701.8
 Individual relief & circuit & loop vents, 914, 916
 Individual vent size, 920.2, 920.3
 Individual vent, 202, 909.1
 Individual venting required, 913.2
 Industrial wastes, defined, 202
 Inlet coupling, B102
 Inside conductors, 1103.1

Inspector, plumbing, defined, 202
 Installation, plumbing fixtures, 403
 unsafe, 102.5
 vent stacks, 904.1
 waste receptors, 807.1.1
 Intercepting devices, 1004.10.1.2
 Interceptor, approval, 1004.1, Appendix M
 commercial, 1004.10.1
 defined, 202
 laundry, 1004.10.1.1, Appendix M
 maintenance, 1004.12, Appendix M
 oil, 1004.5, Appendix M
 required, 1004, Appendix M
 sand, 1004.6, Appendix M
 separators, 1004
 approval, 1004
 slaughter houses, 1004.10.3, Appendix M
 water connection, 1004.9
 Interceptors-separators, accessibility
 of interceptors, 1004.8
 backwater valves, 704.7
 bottling establishments, 1004.10.2, Appendix M
 commercial grinders, 1004.11
 grease interceptors, 1004.4, Appendix M
 interceptors & separators, 1004, Appendix M
 laundries, 1004.10.1, Appendix M
 maintenance, 1004.12, Appendix M
 oil separators, 1004.5, Appendix M
 sand interceptors, 1004.6, Appendix M
 slaughter houses, 1004.10.3, Appendix M
 venting interceptors, 1004.7
 Interceptors-separators,
 Chapter 10, Appendix M
 Interior leader or downspout test, 107, 311.5
 Interior openings, 301.7.2
 Intermediate waste holding tank, B102

Joints and connections, General 309
 increasers & reducers, 307.6
 prohibited joints & connections, 709
 sanitary drainage, 706
 special joints, 612.7
 tightness, 308.1
 type of joints, 308, 612, 709
 unions, 1001.7
 use of joints, 309, 707
 water closets, ped. urinal & trap, 708
 water supply, 612
 Joints, borosilicate glass joints, 706.6
 brazed, 612.4
 burned lead, 308.7
 caulked, 706.2
 cement mortar, 308.6
 elastomeric compression gasket for cast
 iron soil pipe, 706.4
 expansion, 309.6
 flared, 612.3
 hubless cast iron soil pipe system, 706.5
 plumbing fixtures, 403.2
 precast, 308.5
 slip, 309.5, 401.5.2, 401.5.3
 soldered, 612.2
 solvent cement joints for plastic
 pipe and fittings, 308.8
 special, 612.7
 threaded, 308.2
 tightness of, 308.1
 types, 309, 612, 708
 wiped, 308.3

Kitchen sink-waste stack, 716

Large pipe, cleanout, 712.2
 underground, 711.2
 Large piping horizontal drainage, 705.3
 Laundry, interceptors, 1004.10.1.1, Appendix M
 tray, waste outlet, 409.6.1
 Lavatory, 408.1, 607
 waste outlet, 408.1
 water usage, 406
 Lead, 303.7.1
 pipe, 310.2.5
 to cast-iron or steel, 309.2
 Leader, defined, 202
 storm drain size, 1108
 Length, indirect waste piping, 805
 trailer or mobile home, B102
 vent stacks, 920.1
 vent, 920
 Liability, 103, 107
 Light and ventilation, 404.1
 Line valves, 614.2
 Liquid waste, defined, 202
 Load factor, defined, 202
 Loop and circuit venting, 914
 Loop vent, defined, 202, 920.3
 Low pressure cutoff, 607.6

Main, defined, 202
 Main sewer, defined, 202
 Main stack, 904.3
 Main trap, 1105.1
 Main vent, 202, 904.3
 Main vents connect at base, 918
 Maintenance, interceptors, 1004.12
 mobile home park, C111
 plumbing fixtures, 101.3.5
 travel trailer park, B111
 Mandatory water supply, 301.11.2
 Manhole covers, 710.7
 Materials, approved, 303, 603, 703
 backwater valves, 704.7
 design of pipe cleanouts, 710.1
 drainage system, 703
 hangers and anchors, 310.4.1
 labor for tests, 104
 mobile home parks, C105
 plumbing fixtures, Ch. 4
 plumbing installations, 303, 603, 703
 quality and weight, 303
 roof drains, 1107.1
 specific type drainage, 703.2
 specific type vents, 903.2
 specifications, 303.3
 sterile, 804.4
 storm drain, 1103
 travel trailer parks, B106
 vents and venting, 903
 water distribution pipe, tubing & fittings, 611
 water service pipe, 608
 May, defined, 202
 Mechanical excavation, 305.3
 Minimum, size of fixture-supply pipe, 607.3
 size of soil & waste stacks, 714.2
 size of water distribution system, 607.1
 facilities, 407
 pressure at fixture outlets, 607.4
 standards, 303.1
 velocity, 705.4
 Mobile home, C102
 connections-responsibility, C109
 of travel trailer park, B110, B111
 Multiple wash sinks, 409.7
 Multistory bathroom groups, 911.3

- Noise and hazard, 607.8
- Nonpotable water, 202, 605.2
- Notching or cutting, 306.2
- Nuisance, defined, 202

- Obstruction to flow, 307.5
- Offset, defined, 202
 - double, 202
 - drainage piping, 715
 - of 45 degrees or less, 715.1
 - reliefs for vents, 917.3
 - return, defined, 202
 - vents, 917
- Offsets, above highest branch, 715.2
 - less than 45° from horizontal
 - in buildings five or more stories, 917
 - below lowest branch, 715.3
 - more than 45 degrees, 715.4
- Oil separators, 1004.5, Appendix M
- Old house sewers and drains, 704.4
- Open trenches, 305.2
- Openings, exterior, 301.7.1
 - interior, 301.7.2
- Overflow, 408.4
 - fixture, 408.4
 - laundry tray, 409.6

- Parks, mobile homes and travel trailers, B102
- Penalties and violations, 107
- Permit, 103
 - failure to obtain, 103
 - fees, Appendix H
- Person, defined, 202
- Pipe capacities, single stack systems, L104.5
- Pipe cleanouts, concealed piping, 710.3
 - direction of flow, 710.4
 - large pipe, 712.2
 - location, 710.2
 - material and design, 710.1
 - new fixtures prohibited, 710.5
 - size, 711
- Pipe, asbestos cement, 1101.5
 - borosilicate pipe and fittings, 303.7.6, 310.2.7, 310.3.7
 - cast iron soil pipe, 310.2.2, 804
 - horizontal, 310.3
 - inlet and outlet, E105.6
 - large, 711.2, 712.2
 - lead, 310.2.5, 310.3.5
 - plastic pipe and fittings, 303.8, 603, 703, 903
 - protection, 304
 - small, 711.1, 712.1
 - waste, defined, 202
- Pipes through footings or foundation walls, 304.3
- Piping, close to footings, 304.5
- Piping, concealed, 710.3
 - horizontal, 310.3
 - identification, 605
 - in concrete, 310.5
 - material, 303, 603, 703
 - small, 705.2
 - subject to freezing, 304.4, 701.6
 - support of, 305.1
 - vertical, 310.2
- Pitch or grade, defined, 202
- Plans and specifications, B104, C104, I202.1, K101.3, M103.3
- Plastic, pipe & fittings, 303.8
 - materials, 303, 603, 703
- Plumber, responsibility, 103, 107
- Plumbing fixture, Chapter 4
 - alternate materials, 102.7
 - cleaning, 403.1
 - connection, 408.4.2
 - defined, 202
 - dishwashing machine, 409.1
 - drinking fountain, 409.2
 - floor drains, 409.4
 - food waste grinder units, 409.5
 - garbage-can washers, 409.3
 - installation, 403
 - joints, 403.2
 - laundry trays, 409.6
 - lavatories, 408.1
 - minimum facilities, 407
 - multiple wash sinks, 409.7
 - overflows, 408.4
 - prohibited fixtures & connections, 401.5
 - requirements, 405
 - shower receptors & compartments, 409.8
 - sinks, 408.2
 - special fixtures & specialties, 409.9
 - strainers & fixture outlets, 408.3
 - urinals, 409.11
 - washing machines for residences, 409.12
 - water closets, 409.13
- Plumbing installation,
 - hot water storage, Ch. 5
 - materials, 303, 603, 703
 - standards for mobile homes and mobile home parks, C101
 - standards for travel trailers and parks, B101.1
- Plumbing official, 202
 - powers and duties, 102
 - qualifications, 202
- Plumbing system, connection required, 301.11
 - defined, 202
- Plumbing, defined, 202
- Pneumatic ejectors, 915
- Pool, swimming, 807.5
- Potable water, acceptable sources, 604.2
 - defined, 202
 - supply protection, 606
 - system piping disinfection, 601.8
- Power & duties of plumbing official, 102
- Precast joints, 308.5
- Pressure, marking of storage tank, 501.8.2
 - variable street, 607.7
 - minimum, 607.4
- Pressure relief valves, 507.3
- Pressure tanks, 609.9
- Pressure tanks, boilers & relief valves, 609.2
- Privacy screens, 301.2.21, B105.4.2
- Private or private use, defined, 202
- Private sewage disposal system, 701.8, Appendix E
- Private sewer, defined, 202
- Private water supply, 608.6
- Processing, water used for, 614.3
- Prohibited fixtures, 401.5
- Protected traps, 901.2
- Protection, of trap seals, 901.2, 908.2
 - conductors, 1106.2
 - dishwashing machines, 409.1.1
 - pipes, 304
 - potable water supply, 606
 - washing machines, 409.12.1
 - water supply, 606
- Public institutional showers, 409.8.3
- Public or public use, defined, 202
- Public sewer, defined, 202
- Pumps and other appliances, 609.1

- Quality of fixtures, 405
- Quality of water supply, 604

Rainwater conductor protection, 1106.2
 Receptors, 807.1
 Records, D108.3.4
 Reducers and increasers, 307.6
 Reducing valve or regulators for water pressure, 607.9
 Relief vent, 916
 defined, 202
 interceptor, 1004
 size, 920.2
 Relief, outlet wastes, 507.6
 Relief valves, water pressure and temperature, 507.3
 Remedial code, 101.2
 Repairs, alterations, 301.5
 Reports, 104, 1202.2
 Retesting, 104
 Return offset, defined, 202
 Revent pipe, defined, 202
 Reventing individual fixtures, 913
 Revocation of permits, 102.4
 Right of entry, 102.2
 Rise, vertical, 906.2
 Riser, defined, 202
 Rodent proofing, 301.7
 Roof drain, 1107
 defined, 202
 flashings, 1106.4
 flat decks, 1107.3
 materials, 1107.1
 strainers, 1107.2
 Roof, extensions, 905.1

 Safety devices, 507, 613
 Safety, water heater, 501.8.1
 Sand interceptor, 202, 1004.6, Appendix M
 Sanitary and storm sewer, combined, 1106.3
 separated, 704.3
 Sanitary sewer, defined, 202
 Seal loss, single stack systems, L104.3.2, L104.3.3
 Seats, water closet, 409.13.6
 Sediment drains, 501.5
 Separate connections-domestic disposal units, 409.5.1
 Separate controls for each family unit, 610.3
 Separate trap washing machine, 409.12.2
 Separate trenches, 704.1
 Separate venting, 917.2
 Separate vents, 717.7
 Separator, defined, 202, Appendix M
 interceptors, 1004, Appendix M
 slaughter house, 1004.10.3, Appendix M
 Septic tank, 202
 Service buildings, B102, B105, C110
 Service lines near drain or sewer lines, 608.3
 Sewage, defined, 202
 Sewer and drain combination, 1106.3
 Sewer pipe,
 cast iron soil pipe, 303, 703
 clay, 707.1
 concrete, 707.2
 joints, 706.3
 plastic, 308.8, 310.2.6, 310.3.6, 703
 Sewer, & water pipes, 305.6
 building, 202, 704
 house, defined, 202
 in filled ground, 704.2
 lateral, B102
 main, defined, 202
 public, defined, 202
 storm, 202, 1103.4
 Shall, defined, 202
 Shower, 409.8.1
 compartment floor construction, 409.8.2
 heads, 406
 public or institutional, 409.8.3
 receptors and compartments, 409.8
 Side inlet or heel bend, 307.4
 Side vent, defined, 202
 Single stack discharge & ventilating
 pipe systems, 1203.3.3.1, L104
 Single stack plumbing systems, L105
 Sinks, 408.2
 bar and fountain sink traps, 907
 circular type, 409.7.1
 kitchen, waste stack, 716
 multiple wash, 409.7
 straight-line type, 409.7.2
 traps for bars and fountains, 907
 waste outlet, 408.2
 Sizing, of water distribution
 system, 611, 607, Appendix F
 drainage system, 714
 pipe, F103.2
 vents, 920
 Slaughter house, separators, 1004.10.3, Appendix M
 Sleeves, 304.2
 Slip joints, 202, 309.5, 401.5.2
 Slope, defined, 202
 Small pipe cleanouts, 711.1, 712.1
 Small piping horizontal drainage, 705.2
 Soil pipe, defined, 202
 Soldered joints, 612.2
 Soldering bushings, 303.7.4
 Special fixtures and specialties, 409.9
 Special joints, 612.7
 Special materials, 303.7
 Special type separators, 1004.13
 Special waste pipe, defined, 202
 Specifications, and drawings,
 and plans, B104, C104, 1202.1, K101.3, M103.3
 for materials, 303.3
 Splashing, 807.1.3
 Sprinklers (lawn), 606.3
 Stack, defined, 202
 group, defined, 202
 main, 904.3
 of more than 10 branch intervals, 916
 vent, defined, 202
 venting, 202, 912
 Standards, minimum, 303.1, 101.3.4
 State Health Officer, 202
 Sterile materials, 804.4
 Stop and waste valve combination, 608.5
 Storm drain, Chapter 11
 building size, 1108.2
 conductors and connections, 1106
 defined, 202
 general, 1101
 materials, 1103
 roof drains, 1107
 size of leaders and storm drains, 1108
 underground, 1103.3
 values for continuous flow, 1111
 Storm and sanitary drainage combination, 1106.3
 Storm sewer, building, 202, 1103.4
 Straight-line type sink, 409.7.2
 Strain and stresses, 310.5
 Strainers, 1107.2
 and baskets, 807.1.2
 and fixture outlets, 408.3
 Structural safety, 306
 Subdrain, building, 202, 1101.5
 Subsoil drain, 202, 1101.4
 Suction and gravity tanks, 609.8
 Sump, and ejector connections, 717.11

pump equipment design, 717.3
 condensers, 807.3
 defined, 202
 Supplementary tank, auxiliary pressure, 607.5
 Supply fittings, 601.5
 Supports, base of stacks, 310.6.5, L104.3.6
 buried piping, 305.1
 defined, 202
 horizontal piping, 310.3.1
 single stack systems, L104.3.6
 Swimming pools, 807.5

 Tables: battery vent sizing, 920.3
 building drains and sewers, 714.1
 distance of fixture trap from vent, 908.1
 fixture units per fixture or group, 713.1
 fixtures not listed, 713.2
 horizontal fixture branches and stacks, 714.2
 materials for plumbing installation, 303, 603, 703
 minimum facilities & occupant content, 407
 size and length of vents, 920.2
 size of horizontal storm drains, 1108.2
 size of vent stacks, 911.3
 size of vertical leaders, 1108.1
 Tanks, close-coupled, 409.13.4
 controls, 610.2
 Tests,
 final, 104, 311, 311.6, 1203, B108.14, C107.6, D108
 interior leaders or downspouts, 311.5, 1101.9
 material and labor for, 311.1
 methods for drainage and vent
 systems, 311.2
 of building sewer, 311.4
 of drainage and vent systems, 311.2, 701.9, 901.4, B108.14, C107.6
 engineered stack systems, 1203
 water supply system, 311.3, 601.11
 Threaded joints, 308.2
 Threaded pipe to cast iron, 309.1
 Threaded pipe, 310.2.3, 310.3.3
 Threaded unions, 1001.7
 Tightness of joints, 308.1
 Trailer length, B102
 Trap, and strainers-floor drain, 409.4.2
 anti-siphon, 507.1
 cleanouts, 710.6
 dip, 908.3
 drum, 1003.4
 fixture, 1001.8
 function, single stack systems, L104.3
 grease, defined, 202
 house, defined, 202
 level and protection, 1001.3
 main, 1105.1
 prohibited, 1001.5
 protected, 901.2
 relation to fixture drains, 1003.2
 seal protection, 901.2, 908.2
 seal, 202, 1001.2
 single stack systems, L104.4
 size for individual conductors, 1105.4
 size, 1003.1
 storm drain, 1101.3
 to fixture, distance, 1001.9
 to vent distance, 909.1, 909.3
 types, 1003.3
 underground, 1001.4
 Trapping, double, 1001.6
 Traps and cleanouts, Chapter 10
 cleanout clearances, 712
 distance of trap to fixture, 1001.9
 general requirements, 1001
 pipe cleanouts, 710
 size of cleanouts, 711
 type & size of traps & fixture drains, 1003
 Travel trailer, defined, B102
 park, defined, B102
 sanitary service station, defined, B102
 Trenching, excavation, backfill, 305
 Trough Urinals, T407-Note 21

 Underground, drainage piping, 714.4
 piping within buildings, 703.4
 storm drains, 1103.2
 traps, 1001.4
 vent piping, 903.4
 trough urinals, 401.5.1
 Unions (threaded), 1001.7
 Unit load-maximum fixture, 714.1
 Unsafe installations, 102.5
 Urinals, 405, 407, 409.11
 equipped with automatic flush valves, 409.11.2
 trough, 401.5.1, T407-Note 21
 Used or secondhand equipment, 301.8
 Used piping, 601.9.2

 Vacuum breakers, defined, 202
 Values for continuous flow, 713.3
 Values for fixtures, 713.1, Table F101
 Valves, backwater, 409.4.1.3, 704.7, 1101.5, 1101.8
 Valves, float, 409.13.3
 flush, defined, 202
 flushometer, defined, 202
 line, 614.2
 stop-and-waste valves and devices, 608.5
 Variable street pressures, 607.7
 Velocity, minimum, 705.4
 Vent connections, 906
 circuit and loop, 914
 stack, 919
 Vent offset, 917
 relief, 917.3
 Vent piping, above ground, 903.3
 single stack systems, L104.7
 size building sump, 717.6
 underground, 903.4
 Vent relief, 916
 defined, 202
 installation, 904.1
 length, 920.1
 minimum size, 714.2
 multistory bathroom, Table 911.3
 Vent system, and drainage test, 311
 defined, 202
 Vent terminals, 905, 905.6
 extensions through wall, 905.6
 flashings, 905.3
 frost closure, 905.2
 location, 905.5
 vent stack, 904.2
 Vent, battery, 920.3
 branch, defined, 202
 circuit, defined, 202
 common, defined, 202
 continuous, defined, 202
 crown, 908.4
 fittings, 903.5
 fixture, 909
 flashings, 905.3
 grades and connections, 906
 headers, 919
 height above fixtures, 906.3
 individual, 202, 909.1, 920.2
 length, 920
 loop, 202, 914

- main to connect at base, 918
- main, 202, 904.3
- materials, 903
- pipe, defined, 202
- separate, 717.7
- side, defined, 202
- sizes building sump, 717.6
- sizing, 920
- wet, 202, 911
- yoke, defined, 202
- Ventilation and light, 404.1
- Venting, battery, 914.1
 - circuit and loop, 914
 - fixture traps-different levels, 910.2
 - interceptors, 1004.7
 - separate, 917.2
 - stack, 202, 912
- Vents and venting, Chapter 9
 - bar and fountain sink traps, 907
 - circuit and loop, 914
 - common vent, 202, 909
 - fixture vent, 908
 - frost closure, 905.2
 - individual fixture reventing, 913
 - main vents to connect at base, 918
 - materials, 903
 - offsets at an angle less than 45°, 917
 - pneumatic ejectors, 915
 - protection of trap seals, 901.2
 - relief vents, 916
 - size and length of vents, 920
 - stack, 912
 - vent grades and connections, 906
 - vent headers, 919
 - vent stacks, 904
 - vent terminals, 905
 - vents for fixture trap, 910
 - wet venting, 911
- Vertical leader size, 1108.1
- Vertical pipe, defined, 202
- Vertical piping, 310.2
- Vertical rise, 906.2
- Violations and penalties, 107
- Wall-hung bowls, 403.3
- Washing machine, protection, 409.12.1
 - residences, 409.12
 - separate trap, 409.12.2
- Waste acid, piping, 703.6
 - system, 903.6
- Waste outlet, laundry-tray, 409.6.1
 - lavatories, 408.1
 - sink, 408.2
- Waste pipe, indirect, 804
 - indirect, cleaning, 805.2
 - indirect, connections, 804.3
 - indirect, defined, 202
 - indirect, length, 805
 - indirect, material and size, 803
- Waste, clear water, 807.2
 - continuous, defined, 202
 - defined, 202
 - disposal units and single stack systems, L104.5.6
 - grinder, 409.5
 - industrial, defined, 202
 - liquid, 807.2
 - pipe, defined, 202
 - receptor installation, 807.1.1
 - relief outlet, 507.6
 - stacks serving kitchen sinks, 716
- Water closet, 406, 409.13
 - public use of, 409.13.1
 - seat, 409.13.6
- Water distribution pipe, defined, 202
 - tubing and fittings, 603, 611
- Water distribution system, B109
- Water distribution system-sizing, 607, Appendix F
- Water drain and connections, 409.9.1
- Water hammer arresters, air chambers, 607.8
 - shock absorbers, 607.8
 - hazard & noise, 607.8
- Water pumping and storage equipment, 609
- Water supply protection, 606
 - controls, 610
 - distribution, 608
 - mandatory, 606.1
 - quality, 604
 - system, 202, 612.7.4, C108
 - test, 104, 311.3
 - where required, 606.3
- Water tanks, cleaning, painting and repairing, 609.3
 - drains, 609.7
 - overflow, 609.6
- Water heaters and hot water storage tank, Ch. 5
- Water, heating equipment, 501.6
 - main, defined, 202
 - outlet, defined, 202
 - pipes and sewer, 305.6
 - pressure valves or regulators, 607.9
 - pumping and storage equipment, 609
 - relief valves, 507.3
 - riser pipe, defined, 202
 - service pipe, 608
 - used for processing, 614.3
- Water-supply & distribution, Chapter 6
 - allowance for character of water, 601.9
 - color code, 605
 - disinfection of potable water supply piping, 601.8
 - hot-water distribution, 601.10
 - miscellaneous, 614
 - protection of potable water supply, 606
 - quality of water supply, 604
 - safety devices, 507
 - sizing of water distribution system, 607
 - water pumping & storage, 609
 - water supply control, 610
 - water supply distribution, 608, 611
 - water supply mandatory, 601.2
 - water-distribution pipe, tubing & fittings, 608, 611
- Welding or brazing, 309.4
- Wet vent, 202, 911
- Wiped joints, 308.3
- Workmanship, 301.6
- Yoke vent, defined, 202

METRIC CONVERSIONS

MULTIPLY	BY	TO GET	
Length	inches	25.4	mm
	ft	0.3048	m
Area	sq in	645.16	mm ²
	sq ft	0.0929	m ²
Volume	cu in	0.01639	L
	cu ft	28.3169	L
	gal	3.785	L
Mass	lb	0.4536	kg
Mass/unit length	plf (lb/ft)	1.4882	kg/m
Mass/unit area	psf (lb/sq ft)	4.882	kg/m ²
Mass density	pcf (lb/cu ft)	16.02	kg/m ³
Force	lb	4.4482	N
Force/unit length	plf (lb/ft)	14.5939	N/m
Pressure	psi	6.895	kPa
	psf (lb/sq ft)	47.88	Pa
	in. of Hg @ 60°F	3.37685	kPa
stress, modulus of elasticity	psi	6.895	kPa
	psf (lb/sq ft)	47.88	Pa
Second moment of area	in ⁴	416,231	mm ⁴
Section modulus	in ³	16,387.064	mm ³
Temperature	°F-32	5/9	°C
	°F + 459.67	5/9	K
Energy, work, quantity of heat	kWh	3.6	MJ
	Btu	1055	J
	ft • lb (force)	1.3558	J
Power	ton (refrig)	3.517	kW
	Btu/s	1.0543	kW
	hp (electric)	745.7	W
	Btu/h	0.2931	W
Thermal conductance (U value)	Btu/ft ² • h • °F	5.6783	W/m ² • K
Thermal resistance (R value)	ft ² • h • °F/Btu	0.1761	m ² • K/W
Flow	gpm	0.0631	L/s
	cfm	0.4719	L/s
Illuminance	footcandle (lm/sq ft)	10.76	lx (lux)
Velocity (speed)	mph	0.447	m/s
Plane angle	°(angle)	0.01745	rad

